

Owner's manual

# ***PANIGALE V4.S***



Owner's manual

ENGLISH

***PANIGALE V4 S***

This manual forms an integral part of the motorcycle and must be kept with it for its whole service life. If the motorcycle is resold, the manual must always be handed over to the new owner. This manual must be preserved with care. If it is lost or becomes damaged, contact a Ducati Dealer or authorised Service Centre without delay to obtain a new copy of the manual.

The quality standards and safety of Ducati motorcycles are steadily improved as new design solutions, equipment and accessories are developed. While the information contained in this manual is current at the time of going to print, Ducati Motor Holding S.p.A. reserves the right to make changes at any time without notice and without any obligations. For this reason, the illustrations in this manual might differ from your motorcycle.

Any and all reproduction or spreading of the contents herein in whole or in part is forbidden. All rights reserved to Ducati Motor Holding S.p.A. Any request for written authorisation shall be addressed to this company, specifying the reasons for request.

Enjoy your ride!

# Table of contents

Introduction	8
Safety guidelines	8
Warning symbols used in the manual	9
Intended use	10
Rider's obligations	11
Rider's training	13
Apparel	13
Safety "Best Practices"	14
Refuelling	16
Carrying the maximum load allowed	17
Information about carrying capacity	17
Dangerous products - warnings	18
Vehicle identification number	20
Engine identification number	21
Instrument panel (Dashboard)	22

Instrument panel	22
Acronyms and abbreviations used in the Manual	25
Technological Dictionary	25
Information statement on UE directive 2014/53/UE	29
Function buttons	32
Parameter setting and displaying	35
Main and auxiliary functions	40
Engine rpm indication (RPM)	42
Motorcycle speed	43
Gear	44
Clock	45
Engine Coolant temperature	46
Riding Mode (RIDING MODE)	47
Parameter menu and level change	53
DTC	56
DWC	62
DSC	68
EBC	72
ABS	77
DES	83
DQS	84
Function menu	86
Odometer (TOT)	88
Trip meter 1 (TRIP 1)	89

Average Fuel Consumption (CONS. AVG 1) 91	Customizing the Riding Mode: setting the EBC level 127
Average speed (SPEED AVG 1) 93	Customizing the Riding Mode: DSQ enabling/disabling 129
Trip time (TRIP 1 TIME) 95	Customizing the Riding Mode: display mode setting (Info Mode) 131
Ambient air temperature (T-AIR) 97	Customizing the Riding Mode: DES adjustment 133
Partial fuel reserve counter (TRIP FUEL) 98	Customizing the Riding Mode: restoring default settings 149
Trip meter 2 (TRIP 2) 99	Customising Riding Mode: restore default settings (All Default) 151
Instantaneous fuel consumption 100	Pin Code 152
Lap time (LAP Off / On) 101	Changing the Pin Code 157
Player management (PLAYER Off / On) 102	Lap 163
Call management (LAST CALLS) 103	Backlighting setting (Backlight) 169
Setting menu (SETTING MENU) 104	Date setting (Date and Clock) 171
Customising the Riding Mode 107	Clock setting (Date and Clock) 174
Customising the Riding Mode: DAVC 110	Unit of measurement setting (Units) 177
Customizing the Riding Mode: setting the DTC level 113	Service thresholds display (Service) 182
Customizing the Riding Mode: setting the DWC level 116	Tyre setting and drive ratio (Tyre Calibration) 183
Customizing the Riding Mode: setting the DSC level 119	DRL light mode setting (DRL) 187
Customizing the Riding Mode: engine adjustment 122	Bluetooth device setting (Bluetooth) 189
Customizing the Riding Mode: ABS adjustment 124	DDA 200

Turn indicator automatic switch-off feature  
(Turn indicators) 204  
Information (Info) 206  
Assisted start (Launch Control - DPL) 208  
LAP Time 216  
Infotainment 218  
DRL automatic mode indication 226  
OIL SERVICE zero warning 227  
OIL SERVICE or ANNUAL SERVICE or DESMO  
SERVICE indication 228  
OIL SERVICE or ANNUAL SERVICE or DESMO  
SERVICE countdown indication 229  
Warnings/Alarms (WARNING) 230  
Error indication 235  
Viewing side stand status 236  
Light control 237  
Immobilizer system 244  
Keys 245  
Key duplication 246  
Restoring motorcycle operation via the PIN  
CODE 247

## **Controls 249**

Position of motorcycle controls 249  
Ignition switch and steering lock 250

Left-hand switch 251  
Clutch lever 256  
Right-hand switch 257  
Throttle twistgrip 259  
Front brake lever 260  
Rear brake pedal 261  
Gear change pedal 262  
Adjusting the position of the gearchange  
pedal and rear brake pedal 263

## **Main components and devices 267**

Position on the vehicle 267  
Tank filler plug 268  
Seat lock 269  
Side stand 271  
Bluetooth control unit 273  
Steering damper 275  
Front fork adjustment 276  
Adjusting the rear shock absorber 277

## **Riding the motorcycle 278**

Running-in recommendations 278  
Pre-ride checks 281  
Engine start 285

Moving off 288  
Braking 288  
Anti-Lock Braking System (ABS) 289  
Stopping the motorcycle 290  
Parking 291  
Refuelling 292  
Tool kit and accessories 295

## Main use and maintenance operations 296

Removing the fairing 296  
Change air filter 297  
Checking coolant level and topping up, if necessary 298  
Checking brake and clutch fluid level 299  
Checking brake pads for wear 301  
Charging the battery 302  
Charging and maintenance of the battery during winter storage 309  
Checking drive chain tension 312  
Lubricating the drive chain 314  
Replacing the high and low beam bulbs 319  
Rear turn indicators 319  
Aligning the headlight 320

Adjusting the rear-view mirrors 323  
Tubeless tyres 324  
Check engine oil level 326  
Cleaning the motorcycle 328  
Cleaning and replacing the spark plugs 330  
Storing the motorcycle 331  
Important notes 332

## Scheduled maintenance chart 333

Scheduled maintenance chart: operations to be carried out by the dealer 333  
Scheduled maintenance chart: operations to be carried out by the customer 338

## Technical data 339

Weights 339  
Dimensions 340  
Fuel, lubricants and other fluids 341  
Engine 343  
Timing system 344  
Performance data 345  
Spark plugs 345  
Fuel system 345  
Brakes 345

Transmission 346  
Frame 347  
Wheels 347  
Tyres 347  
Suspension 347  
Exhaust system 348  
Available colours 348  
Electric system 349

**Routine maintenance record 356**

Routine maintenance record 356

# Introduction

## Safety guidelines

We would like to welcome you among Ducati enthusiasts, and congratulate you on your excellent choice of motorcycle. We think you will ride your Ducati motorcycle for long journeys as well as short daily trips. Ducati Motor Holding S.p.A. wishes you smooth and enjoyable riding.

Your motorcycle is the result of Ducati Motor Holding S.p.A.'s on-going research and development efforts. It is important that you preserve its quality standard by strictly observing the maintenance plan and using genuine spare parts.

This manual provides instructions on minor maintenance operations. Major maintenance operations are described in the Workshop Manual available to Ducati Authorised Service Centres. In your own interest, for your safety and in order to guarantee product reliability, you are strongly advised to refer to our authorised Dealers and

Service Centres for any operations listed in the scheduled maintenance chart, see page 333. Our highly skilled staff have access to special implements and appropriate equipment required to perform any servicing job at best, and use Ducati original spare parts only as the best guarantee for full interchangeability, smooth running and long life. All Ducati motorcycles come with a Warranty Card. The warranty does not apply to motorcycles used in racing competitions. Tampering with or altering any components, even partially, will make the warranty null and void effective immediately. Improper or poor maintenance, using other than original spare parts or parts not expressly approved by Ducati may invalidate your warranty rights and lead to damage or loss of performance.

Your safety and that of other road users are very important. Ducati Motor Holding S.p.A. recommends that you ride responsibly. Before using your motorcycle for the first time, read this entire manual carefully and closely follow the guidelines outlined in it. The manual provides full information on proper motorcycle operation and maintenance. In case of any doubts, please contact a Dealer or Authorised Service Centre.

## Warning symbols used in the manual

Several kinds of warnings are used as an alert of the possible hazards for you or other persons such as:

- Safety labels on the motorcycle;
- Safety messages preceded by a warning symbol and either WARNING or IMPORTANT.



### Attention

Failure to comply with these instructions may put you at risk, and could lead to severe injury or even death of the rider or other persons.



### Important

Possibility of damaging the motorcycle and/or its components.



### Note

Additional information about the current operation.

The terms RIGHT and LEFT are referred to the motorcycle viewed from the riding position.

## Intended use

This motorcycle must be ridden on asphalt or on flat and even surfaces, only. This motorcycle may not be used for riding on dirt trails or for off-road riding.



### Attention

Off-road riding may lead to loss of control and result in vehicle damage, personal injuries or even death.



### Attention

This motorcycle may not be used to tow any trailers or with a side-car attached; this can lead to loss of control and result in an accident.



### Attention

The total weight of the motorcycle in running order including rider, luggage and additional accessories should not exceed 370kg/816 lb.



## Important

Using the motorcycle under extreme conditions, such as very damp and muddy roads or dusty and dry environment, could cause above-average wear of components like the drive system, the brakes or the air filter. If the air filter is dirty, the engine could get damaged. Therefore, this might translate in required service or replacement of the wear parts earlier than specified in the scheduled maintenance chart.

## Rider's obligations

All riders must hold a valid licence.



### Attention

Riding without a licence is illegal and is prosecuted by law. Always make sure you have your licence with you when riding. Do not let inexperienced riders or persons without a valid licence use your motorcycle.

Do not ride under the influence of alcohol and/or drugs.



### Attention

Riding under the influence of alcohol and/or drugs is illegal and is prosecuted by law.

Do not take prescription or other drugs before riding unless you have consulted your doctor about their side effects.



### Attention

Some medications and drugs may cause drowsiness or other effects that slow down reaction time and the rider's ability to control the motorcycle, possibly leading to an accident.

Some states require vehicle insurance.



### Attention

Check your state laws. Obtain insurance coverage and keep your insurance document secure with the other motorcycle documents.

To protect rider and passenger safety, some states mandate the use of a certified helmet.



### Attention

Check your state laws. Riding without a helmet may be punishable by law.



### Attention

Riders without helmets are more likely to suffer severe bodily injury or die if they are in an accident.



## Attention

Check that your helmet complies with safety specifications, permits good vision, is the right size for your head, and carries a certification label indicating that it conforms to the standards in force in your state. Road traffic laws differ from state to state. Learn about traffic laws in your state before riding and always obey them.

## Rider's training

Accidents are frequently due to inexperience. Riding, manoeuvres and braking must be performed in a different way than on the other vehicles.

### Attention

Untrained riders or a wrong use of the vehicle may lead to loss of control, serious injuries or even death.

## Apparel

Riding gear is very important for safety. Unlike cars, a motorcycle offers no impact protection in an accident.

Proper riding gear includes helmet, eye protection, gloves, boots, long sleeve jacket and long trousers.

- The helmet must meet the requirements listed at page 11; if your helmet does not have a visor, use suitable eye wear;
- Use five-finger gloves made from leather or abrasion-resistant material;
- Riding boots or shoes must have non-slip soles and offer ankle protection;

- Jacket, trousers or riding suit must be made from leather or abrasion-resistant material and have high-visibility colours and inserts.

### Important

Never wear loose clothing, items or accessories that may become tangled in motorcycle parts.

### Important

For your safety, always wear suitable protective gear, regardless of season and weather.

## Safety "Best Practices"

These few simple operations are critical to people safety and to preserving the full performance of your motorcycle. Never forget to perform them before, while and after riding.

### Important

Closely follow the indications provided at chapter "Riding the motorcycle" during the running-in period.

Failure to follow these instructions releases Ducati Motor Holding S.p.A. from any liability whatsoever for any engine damage or shorter engine life.

### Attention

Before riding your motorcycle, become familiar with the controls you will need to use when riding.

Perform the checks recommended in this manual before each ride (see page 288).

### Attention

Failure to carry out these checks before riding may lead to motorcycle damage and injury to rider.

### Attention

Start the engine outdoors or in a well ventilated area. The engine should never be started or run indoors.

Exhaust gases are poisonous and may lead to loss of consciousness or even death within a short time. Use proper body position while riding.

### Important

Rider must hold the handlebar with both hands at ALL TIMES while riding.

### Important

Rider should keep his feet on the footpegs when the motorcycle is in motion.

### Important

Be very careful when tackling road junctions, or when riding in areas near exits from private grounds, car parks or on slip roads to access motorways.

### Important

Be sure you are clearly visible and do not ride within the blind spot of vehicles ahead.



### **Important**

ALWAYS signal your intention to turn or pull to the next lane in good time using the suitable turn indicators.



### **Important**

Park your motorcycle where no one is likely to knock against it, and use the side stand. Never park on uneven or soft ground, or your motorcycle may fall over.



### **Important**

Visually inspect the tyres at regular intervals for detecting cracks and cuts, especially on the side walls, bulges or large spots that are indicative of internal damage. Replace them if badly damaged. Remove any stones or other foreign bodies caught in the tread.



### **Attention**

Engine, exhaust pipes and silencers stay hot long after the engine is switched off; pay particular attention not to touch the exhaust system with any body part and do not park the vehicle next to flammable material (wood, leaves etc.).



### **Attention**

Always remove the key when you leave your motorcycle unattended and make sure it is not accessible to persons not authorised to use the motorcycle.

## Refuelling

### Fuel label

Fuel identification label

Refuel outdoors with engine off.

Do not smoke or use open flames while refuelling. Be careful not to spill fuel on engine or exhaust pipe. Never completely fill the tank when refuelling. Fuel should never be touching the rim of filler recess.

When refuelling, avoid breathing the fuel vapours and prevent fuel from reaching your eyes, skin or clothes.

### Attention

The motorcycle is only compatible with fuel having a maximum content of ethanol of 10% (E10). Using fuel with ethanol content over 10% is forbidden. Using it could result in severe damage of the engine and motorcycle components. Using fuel with ethanol content over 10% will make the warranty null and void.

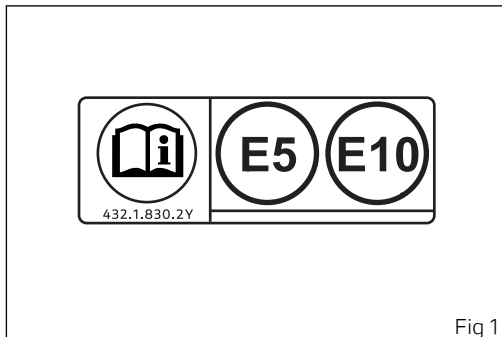

Fig 1

### Attention

In case of indisposition caused by breathing fuel vapours for a long time, stay in the open air and contact your doctor. In case of contact with eyes, thoroughly flush with water; in case of contact with skin, immediately clean with water and soap.

### Attention

Fuel is highly flammable, in case of accidental spillage of fuel on your clothes it is necessary to change into clean clothes.

## Carrying the maximum load allowed

Your motorcycle is designed for long-distance riding, carrying the maximum load allowed in full safety. Even weight distribution is critical to preserving these safety features and avoiding trouble when performing sudden manoeuvres or riding on bumpy roads.

### Attention

Do not exceed the total permitted weight for the motorcycle and pay attention to information provided below regarding load capacity.

## Information about carrying capacity

### Important

Arrange your luggage or heavy accessories in the lowest possible position and close to motorcycle centre.

### Important

Never fix bulky or heavy objects to the handlebar or to the front mudguard as this would affect stability and cause danger.

### Important

Be sure to secure the luggage to the supports provided on the motorcycle as firmly as possible. Improperly secured luggage may affect stability.

### Important

Do not insert any objects you may need to carry into the gaps of the frame as these may foul moving parts.

### Attention

Make sure the tyres are inflated to the proper pressure and that they are in good condition.

Refer to paragraph "Tyres" on page 324.

## Dangerous products - warnings

Used engine oil

### Attention

Prolonged or repeated contact with used engine oil may cause skin cancer. If working with engine oil on a daily basis, we recommend washing your hands thoroughly with soap immediately afterwards. Keep away from children.

Brake dust

Never clean the brake assembly using compressed air or a dry brush.

Brake fluid

### Attention

Spilling brake fluid onto plastic, rubber or painted parts of the motorcycle may cause damages. Protect these parts with a clean shop cloth before proceeding to service the system. Keep away from children.

### Attention

The fluid used in the brake system is corrosive. In the event of accidental contact with eyes or skin, wash the affected area with abundant running water.

Coolant

Engine coolant contains ethylene glycol, which may ignite under particular conditions, producing invisible flames. Although the flames from burning ethylene glycol are not visible, they are still capable of causing severe burns.

### Attention

Take care not to spill engine coolant on the exhaust system or engine parts.

These parts may be hot and ignite the coolant, which will subsequently burn with invisible flames. Coolant (ethylene glycol) is irritant and poisonous when ingested. Keep away from children. Never remove the radiator cap when the engine is hot. The coolant is under pressure and will cause severe burns.

The cooling fan operates automatically: keep hands well clear and make sure your clothing does not snag on the fan.

## Battery



### **Attention**

The battery gives off explosive gases; never cause sparks or allow naked flames and cigarettes near the battery. When charging the battery, ensure that the working area is properly ventilated.

## Vehicle identification number



### Note

These numbers identify the motorcycle model and should always be indicated when ordering spare parts.

It is recommended to record the frame number of your motorcycle in the space below.

---

Frame number

---

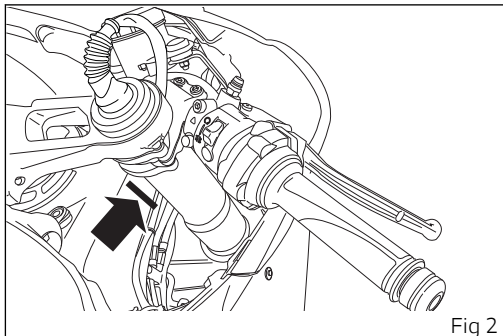

## Engine identification number



### Note

These numbers identify the motorcycle model and should always be indicated when ordering spare parts.

The engine identification number is located in the motorcycle front side on the horizontal head cylinder lower side, near the starter motor and the generator cover.

It is recommended to record the number of your motorcycle's engine in the space below.

---

Engine number

---

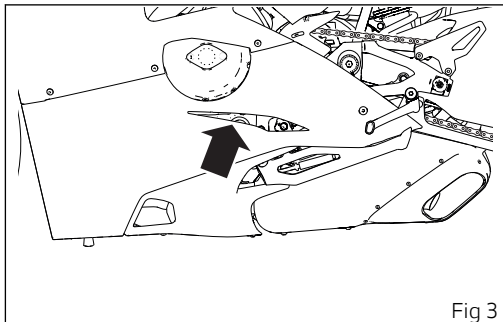

Fig 3

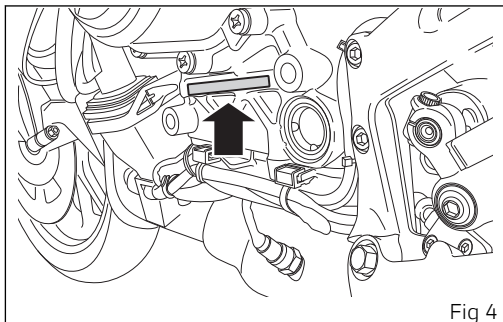

Fig 4

# Instrument panel (Dashboard)

## Instrument panel

1) DISPLAY

2) NEUTRAL LIGHT N (GREEN)

Comes on when in neutral position.

3) GENERIC ERROR WARNING LIGHT  (AMBER YELLOW)

It turns on when there are any "vehicle" errors, i.e. active errors triggered by any control unit other than the engine control unit.

4) HIGH BEAM LIGHT  (BLUE)

It turns on to indicate that the high beam lights are on and when the flasher is activated.

5) FUEL WARNING LIGHT  (AMBER YELLOW)

Comes on when fuel is low (see chapter "Top-ups").

6) TURN INDICATOR LIGHTS  (GREEN)

Illuminates and flashes when the turn indicator is in operation.

7) ENGINE OIL PRESSURE LIGHT  (RED)

Comes on when engine oil pressure is too low. It must turn on at "KEY-ON", but must turn off a few seconds after the engine has started. It may shortly come on when the engine is hot, however, it should go out as the engine revs up.



## Important

If the ENGINE OIL light stays ON, stop the engine or it may suffer severe damage.

8) DAVC LIGHT (AMBER YELLOW)

This light indicates DTC/DWC/DSC system enabling/disabling status.

- Light off: DTC/DWC/DSC enabled and functioning;
- Light ON flashing: DTC/DWC/DSC enabled, but with degraded performance;
- Light steady ON: DTC/DWC/DSC disabled and/or not functioning due to a fault in the control unit.

9) ENGINE DIAGNOSIS - MIL LIGHT  (AMBER YELLOW)

It turns on in the case of "engine" errors that in some cases will lock the engine.

#### 10) ABS LIGHT (AMBER YELLOW)

Indicates ABS status.

- Light off: ABS enabled and functioning;
- Light ON flashing: ABS in self-diagnosis and/or functioning with degraded performance;
- Light steady ON: ABS disabled and/or not functioning due to a fault in the ABS control unit.

#### 11) DES LIGHT (AMBER YELLOW)

- Light OFF: DES active;
- Light ON flashing: DES in degraded mode or in initialisation status;
- Light steady ON: presence of DES malfunction.

#### 12) DRL LIGHT (GREEN)

Indicates DRL lights status (not present in China, Canada and Japan versions).

- Light OFF: DRL light off;
- Light steady ON: DRL light active;
- Light ON flashing: DRL light in fault.

#### 13) DTC INTERVENTION (AMBER YELLOW)

- Light OFF: no intervention;
- Light steady ON: advance cut or injection cut.

#### 14) OVER REV / IMMOBILIZER SYSTEM

**Over rev:**

- Light OFF: no intervention;
- Light ON flashing: limiter.



#### **Note**

Each calibration of the Engine Control Unit may have a different setting for the rev limiter.

**Immobilizer:**

- Light OFF: key-on status or key-off status for over 12 hours;
- Light ON flashing: key-off status;



#### **Important**

If the display shows the message "TRANSPORT MODE", immediately contact your Ducati Dealer that will delete this message and ensure the full operation of the motorcycle.

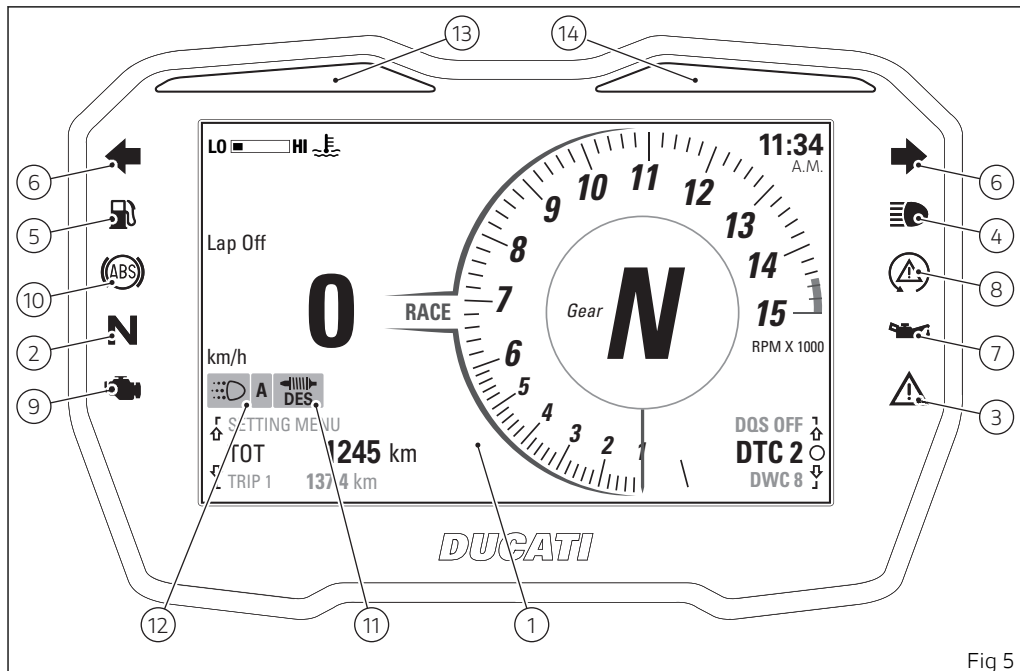

Fig 5

## Acronyms and abbreviations used in the Manual

ABS  
Antilock Braking System  
BBS  
Black Box System  
CAN  
Controller Area Network  
DDA  
DUCATI Data Acquisition  
DES  
Ducati Electronic Suspension  
DPL  
Ducati Power Launch  
DQS  
DUCATI Quick Shift  
DSB  
Dashboard  
DSC  
Ducati Slide Control  
DTC  
DUCATI Traction Control  
DWC  
DUCATI Wheelie Control  
EBC

DUCATI Engine Brake Control  
ECU  
Engine Control Unit  
GPS  
Global Positioning System  
IMU  
Inertial Measurement Unit

## Technological Dictionary

### Engine Brake Control (EBC)

The engine brake control system (EBC) works together with the slipper clutch to avoid and control the rear wheel lock-up during aggressive downshifting.

EBC features a three-tiered operating system and is integrated in the three Riding Modes.

### Riding Mode

The rider of a Panigale V4 can choose from 3 different preset motorcycle configurations (Riding Modes) and pick the one that best suits his/her riding style or ground conditions. The Riding Modes allow user to instantly change the engine power delivery (Power Mode), ABS, DTC, DQS, EBC and DWC settings and instrument panel graphics.

The Riding Modes available for the Panigale V4 are: Race, Sport and Street. Within every Riding Mode, the rider can customise any settings.

## Power Mode

The Power Modes are the different engine maps the rider can select to change power level and delivery to suit his/her own riding style and surface conditions. For the Panigale V4 there are three Power Modes, one for each Riding Mode:

- LOW, with 'soft' power delivery;
- MEDIUM, with 'soft' power delivery;
- HIGH, with 'instant' power delivery.

## Ride by Wire (RbW)

The Ride by Wire system is the electronic device that controls throttle opening and closing. Since there is no mechanical connection between the throttle twistgrip and the throttle bodies, the ECU can adjust power delivery by directly affecting throttle opening angle.

The Ride by Wire system allows you to obtain different power level and delivery according to the selected Riding Mode (Power Mode), but even to

accurately control the engine brake (EBC), thereby helping to control the rear wheel slipping (DTC).

## Suspension Control Unit (SCU)

The Panigale V4 is equipped with the Öhlins Smart EC system applied to semi-active suspension systems and electronic steering damper (DES). This system communicates with the Bosch inertial platform to dynamically respond to changing road and riding conditions, thereby ensuring the best possible damping performance and total control of the motorcycle. It features two operating modes: Fixed, which is not an active mode and allows the rider to set specific compression and rebound settings for the front and rear suspensions (as well as the steering damper preload). These settings are maintained steady by the system until rider changes them, as it happens on a suspension system with standard adjustment. As an alternative, system features the Event Based mode, which is semi-active and allows the rider to select suspension "behaviour" levels, from hard to soft. In this mode, system dynamically adjusts compression, rebound and hardness of the damper depending on riding conditions, while still keeping to the overall "behaviour" level previously selected by the rider.

## Ducati Traction Control (DTC)

The Ducati Traction Control system (DTC) supervises the rear wheel slipping control and settings vary through eight different levels that are calibrated to offer a different tolerance level to rear wheel slipping. Each Riding Mode features a pre-set intervention level. Level 8 indicates system intervention whenever a slight slipping is detected, while level 1 is for track use and very expert riders because it is less sensitive to slipping and intervention is hence softer.

## Ducati Slide Control (DSC)

The Ducati Slide Control (DSC) system assists the rider during the acceleration when exiting a curve in order to better control the side slipping of the rear wheel. The system thus improves the intervention of the single DTC function that works on the tyre longitudinal slipping providing better assistance in extreme riding conditions.

## Anti-lock Braking System (ABS)

The ABS system fitted to the Panigale V4 is a safety system preventing wheel lockup while braking, adopting different strategies depending on the

selected level while riding with the motorcycle straight and not leaning over. The active presence of strategies and their intervention level depend on the selected level. The ABS features 3 levels, one associated to each Riding Mode.

The Panigale V4 ABS features a "cornering" function that optimises ABS functionality to the conditions where the motorcycle is leaning over, thus preventing wheel lockup and slipping as much as possible, within the physical limits allowed by the vehicle and by the road conditions. The cornering function is active on all the ABS levels.

According to the selected level, the Panigale V4 ABS can implement the anti lift-up function for the rear wheel so as to guarantee not only a reduced stopping distance under braking, but also the highest possible stability.

## Ducati Quick Shift (DQS)

The DQS with up/down feature allows the rider to upshift and downshift without using the clutch lever. It includes a two-way microswitch - built in the lever mechanism - that outputs a signal to the engine control unit whenever the gearchange is operated. The system works in a separate way for upshifting and downshifting, and combines the action on

ignition advance and injection, available in the upshift system, with controlled throttle opening for operation during downshifting.

### Ducati Wheelie Control (DWC)

The Ducati Wheelie Control system (DWC) supervises control of wheelie movement and settings vary through eight different levels that are calibrated to offer a different prevention and reaction to wheelies. Each Riding Mode features a pre-set intervention level. Level eight indicates a setting that minimises motorcycle tendency to shift up in a wheelie and maximises reaction to the same, if it occurs. While level one is for expert riders and features a lower wheelie control in terms of prevention and less strong reaction to the same, if it occurs.

### Ducati Data Analyser+ (DDA+)

DDA+ is the latest generation of the Ducati Data Analyzer, with built-in GPS signal to create a "virtual finish line". The system automatically detects lap end and stops the lap timer, without the rider needing to do anything. Thanks to the built-in GPS signal, it also shows the trajectories on track map and the key motorcycle parameters: throttle

opening, speed, rpm, gear engaged, engine temperature, DTC intervention.

### Ducati Power Launch (DPL)

The Ducati Power Launch (DPL) helps the rider in the delicate sport starting phase from a standstill to control the power delivered by the vehicle. The DPL system works with three intervention levels, each calibrated to offer a different start assist degree.

## Information statement on UE directive 2014/53/UE

Your vehicle is equipped with a range of radio equipment. The manufacturers of this radio equipment declare that this equipment complies with Directive 2014/53/EU where required by law.

The complete text of the EU declarations of conformity is available at the following web address:  
certifications.ducati.com

### Manufacturers' addresses

All relevant components pursuant to 2014/53/EU must bear the manufacturer's address. For components that, due to their size or nature, cannot be furnished with a sticker, the respective manufacturers' addresses as required by law are listed here:

Radio equipment installed in the vehicle	Manufacturers' addresses
Bluetooth/ DSB	COBO S.p.a. Via Tito Speri, 10 25024 - Leno (BS) Italy
Hands free	ZADI S.p.a. Via Carl Marx, 138 41012 - Carpi (MO) Italy
Hands free	ASHAI DENSO 6-2-1 Somejidai, Hamakita-ku, Hamamatsu, Shizuoka 434-0046 Japan
Djair®	Dainese S.p.a. Via dell'Artigianato, 35 36060 - Molvena (VI) Italy
E-Lock	ZADI S.p.a. Via Carl Marx, 138 41012 - Carpi (MO) Italy
GPS	PROSA S.r.l. Via dell'Elettricità, 3/d 30175 - Venezia Marghera (VE) Italy
DSB	MAE Via Presolana 31/33 24030 - Medolago – Bergamo - Italy

<b>DSB</b>	<b>EGICON</b> Via Posta Vecchia, 36, Mirandola (MO) - Italy
<b>TPMS</b>	<b>LDL Technology S.A.S.</b> Parc Technologique du Canal, 3 rue Giotto 31520 Ramonville - France
<b>TPMS</b>	<b>PACIFIC Industrial Co., Ltd.</b> 1300-1 Yokoi, Godo-cho, Anpachi-gun, Gifu 503-2397, JAPAN
<b>Anti-theft system</b>	<b>PATROLLINE</b> Via Cesare Cantù, 15/C Albavilla (CO) - Italy

	<b>Frequency band</b>	<b>Max Transmission Power</b>
<b>Bluetooth</b>	2,402 MHz ÷ 2,480 MHz	4.4 mW
<b>Hands free unit</b>	134.2 KHz (AD) 134.5 KHz (Zadi)	73dB $\mu$ V/m (10m) <42 dB $\mu$ A/m (10m)
<b>Hands free key</b>	868.35 MHz (Zadi) 434 MHz (AD)	25 mW -20 dBm (3m)
<b>Djair®</b>	868 MHz 2.4 GHz	+10 dB +3 dB
<b>E-Lock</b>	134.5 KHz	<42 dB $\mu$ A/m (10m)
<b>GPS</b>	1575.4 MHz	
<b>DSB</b>	134.2 KHz 120 KHz – 140 KHz	178.5 dB $\mu$ A/m <66 dB $\mu$ A/m (10m)
<b>TPMS</b>	868.35 MHz (LDL) 433.05 ÷ 434.79MHz (Pacific)	-7 dBm +/- 4 dB 100 dB $\mu$ V/m

Anti-theft system	433.92 MHz ( $\pm 75$ KHz)	<0.6 mA
-------------------	----------------------------	---------

## Function buttons

### 1) UP CONTROL SWITCH "▲"

Button used to display and set instrument panel parameters with the position "▲".

### 2) DOWN CONTROL SWITCH "▼"

Button used to display and set instrument panel parameters with the position "▼".

### 3) HIGH-BEAM FLASH BUTTON (FLASH)

The high-beam flash button may also be used for LAP functions.

### 4) CONFIRM MENU / RIDING MODE CHANGE MENU BUTTON

Button used to confirm, to enter Riding Mode change menu and to enter Setting Menu.

### 5) "SELECT" QUICK SELECTION BUTTON

Button used to select / confirm the quick level change

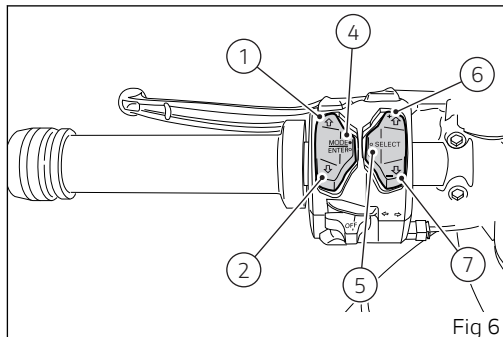
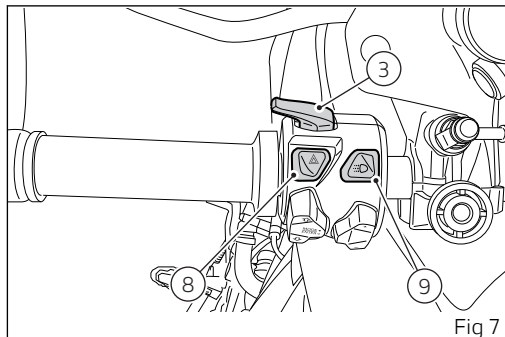

Fig 6

- 6) UP "▲" QUICK SELECTION BUTTON (Fig 6)  
Button used for UP selection of quick level change
- 7) DOWN "▼" QUICK SELECTION BUTTON (Fig 6)  
Button used for DOWN selection of quick level change
- 8) HAZARD BUTTON  
Button used to switch on/off all four turn indicators  
(Hazard function).
- 9) DRL BUTTON  
Button used to switch on/off the DRL lights (not  
present in China, Canada and Japan versions).





## Attention

Using the quick selection buttons (6) and (7) while riding could result in dangerous situations, since it immediately changes the triggering threshold of the currently associated function: traction control (DTC), wheelie control (DWC), engine brake control (EBC). On your vehicle this setting can be changed while riding, regardless of the throttle twistgrip position: use this control carefully in order to avoid any dangerous situation. You are advised against using the UP or DOWN buttons while riding the motorcycle. Ducati shall not be liable for any loss or damage whatsoever linked to or connected with the Customer or third parties disabling or manually setting the riding aid functions.

## Parameter setting and displaying

Upon key-on, the instrument panel displays the DUCATI logo and carries out a sequential check of the LED warning lights.

After this routine, the instrument panel displays the main page in one of the available layouts (TRACK, ROAD), depending on the one in use before last KEY-OFF.

During this first check stage, if the motorcycle speed exceeds 5 km/h (3 mph) (actual speed), the instrument panel will stop:

- the display check routine and display the standard screen containing updated information;
- the warning light check routine and leave ON only the warning lights that are actually active at the moment.

Two different main page layouts are available:  
TRACK and ROAD.

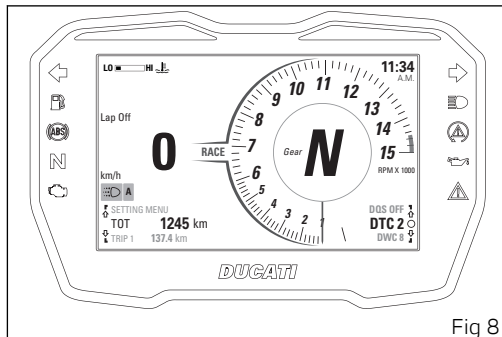

Fig 8

Data displayed on the main screen for TRACK layout are as follows:

- 1) Motorcycle speed
- 2) Engine Coolant temperature
- 3) Set Riding Mode
- 4) Gear indication
- 5) Rev counter
- 6) Clock
- 7) LAP time (Lap) - if activated
- 8) Bluetooth indication (only if Bluetooth is available and active)
- 9) Indication of missed calls or received sms / mms / e-mails (only if Bluetooth is active and a smartphone is connected)
- 10) Connected device indication (only if Bluetooth is available and active)
- 11) Function menu
- 12) Parameter menu and level change
- 13) Status of DRL Lights (Auto, Manual or disabled) / Low Beams (active / not active): in this area DRL and Low Beams warning lights alternate (DRL lights are not present in China, Canada and Japan versions).

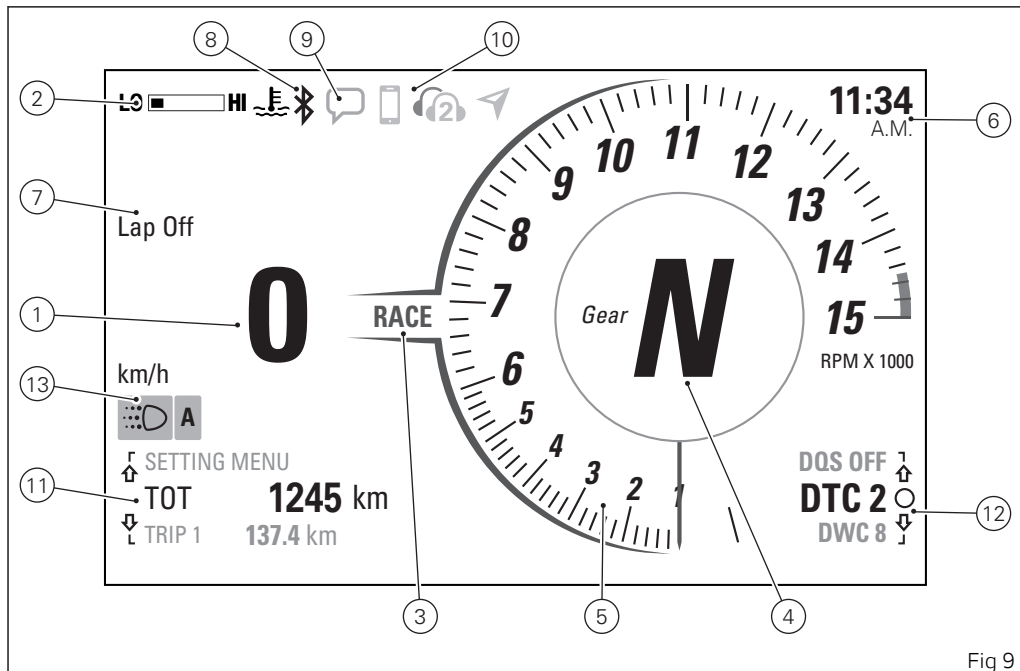

Fig 9

Data displayed on the main screen for ROAD layout are as follows:

- 1) Motorcycle speed
- 2) Engine Coolant temperature
- 3) Set Riding Mode
- 4) Gear indication
- 5) Rev counter
- 6) Clock
- 7) Infotainment — Player (volume / track selection / track control)(only if Bluetooth active, smartphone connected and Player active)
- 8) Bluetooth indication (only if Bluetooth is active)
- 9) Indication of missed calls or received sms / mms / e-mails (only if Bluetooth is available and active and a smartphone is connected)
- 10) Connected device indication (only if Bluetooth is available and active)
- 11) Function menu
- 12) Parameter menu and level change

13) Status of DRL Lights (Auto, Manual or disabled) / Low Beams (active / not active): in this area DRL and Low Beams warning lights alternate (DRL lights are not present in China, Canada and Japan versions).

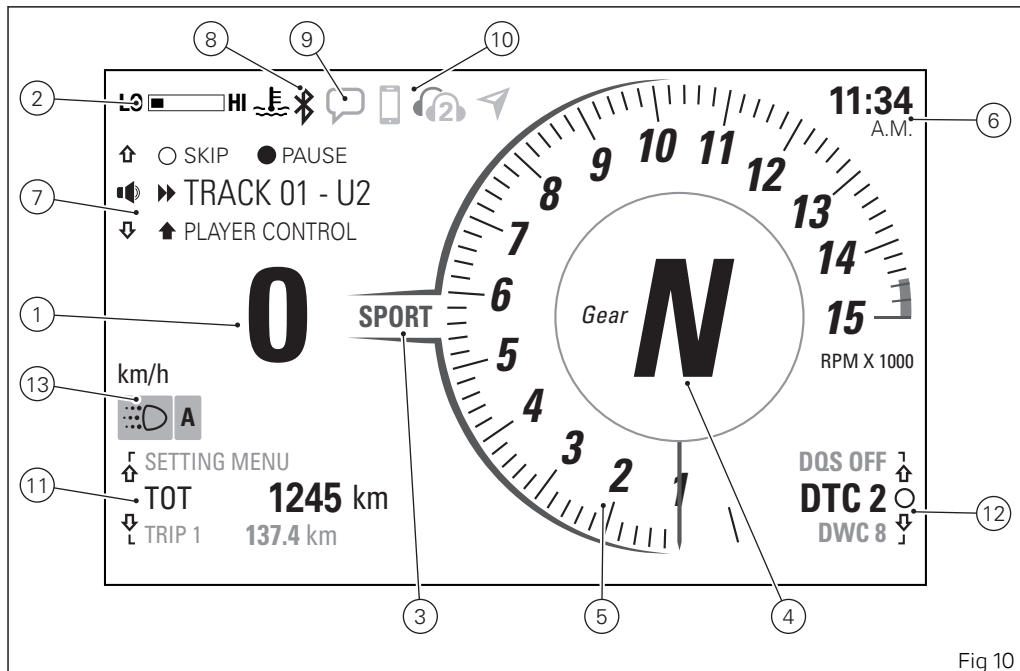

Fig 10

## Main and auxiliary functions

The functions displayed in the Standard screen are the following:

### Main information

- Rev counter
- Motorcycle speed
- Engine Coolant temperature
- Clock
- Set Riding Mode
- Gear indication
- Parameter and level change menu:
  - DTC
  - DWC
  - DSC
  - EBC
  - ABS
  - DES
  - DQS

- Function menu:
  - Odometer (TOT)
  - Trip meter 1 (TRIP 1)
  - Average Fuel Consumption (CONS. AVG 1)
  - Average speed (SPEED AVG 1)
  - Trip time (TRIP 1 TIME)
  - Ambient air temperature (T-AIR)
  - Partial fuel reserve counter (TRIP FUEL)
  - Trip meter 2 (TRIP 2)
  - Instantaneous fuel consumption (CONS. I.)
  - Lap time off/on (LAP) (only in TRACK mode)
  - Player management on/off (PLAYER) (only in ROAD mode and only if Bluetooth is active with a smartphone connected)
  - Call management (LAST CALLS) (only in ROAD mode and only if Bluetooth is active with a smartphone connected)
  - Setting menu (SETTING MENU)

The functions within the Setting Menu that can be modified by the user are the following:

- Riding Mode customisation: within this menu, rider can customise the following:
    - DTC/DWC/DSC levels setting (DAVC)
    - engine setting (Engine)
    - ABS level (ABS)
    - EBC level setting (EBC)
    - DQS level (DQS)
    - display mode customisation (Info Mode)
    - electronic suspension setting (DES)
    - Reset to default settings (DEFAULT)
  - PIN CODE activation and modification (Pin Code)
  - Lap time (Lap)
  - backlighting setting (Backlight)
  - Date and time setting (Date and Clock)
  - unit of measurement setting (Units)
  - Service thresholds display (Service)
  - tyre calibration (Tire Calibration)
  - DRL lights setting (DRL) (DRL lights are not present in China, Canada and Japan versions)
  - indication of associated devices, pairing, deletion of devices and displaying of Bluetooth version (Bluetooth)
  - turn indicator automatic switch-off feature (Turn indicators)
  - DDA
- Info (Info):
    - battery indication (BATTERY)
    - engine rpm digital indication (RPM)

### Additional information

- Infotainment - Bluetooth
- Lap time (LAP)
- DPL level
- SERVICE indication
- SERVICE count-down indication
- Warnings/Alarms
- Side stand status (Side Stand)

## Engine rpm indication (RPM)

The instrument panel receives the engine rpm information and displays it using a needle rev counter.

The rev counter is displayed in mode (A) in TRACK view and is displayed in mode (B) in ROAD view.

The needle movement is followed by a grey wake in DAY mode (C) and by a white wake in NIGHT mode. When exceeding 13000 rpm, the needle wake turns amber yellow (for Performance engine control units the threshold is 12500 rpm), while when the first limiter threshold (Over-rev) is reached, the wake turns red and warning light 13 (see "Instrument panel") turns on. The red wake flashes when the limiter (Over-rev) activates.

If the number of rpm is lower than 1000, the needle wake is not displayed.

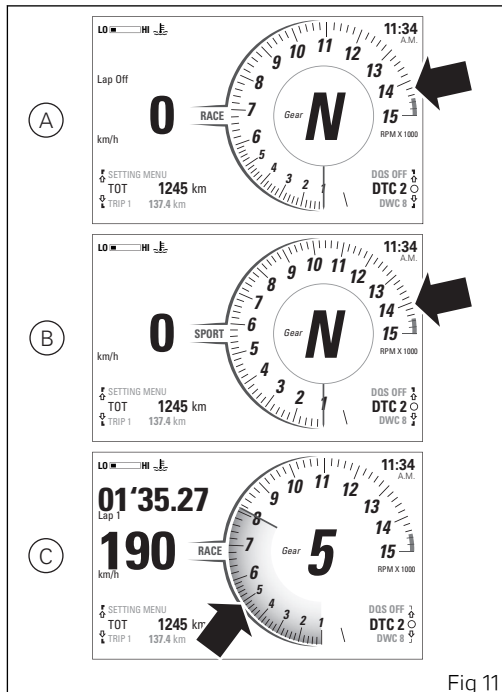

Fig 11

## Motorcycle speed

The instrument panel receives information about the actual vehicle speed (calculated in km/h) and displays the value increased by 5% and converted in the set unit of measurement (mph or km/h).

A string of dashes "- - -" is displayed with the set unit of measurement if:

- speed is higher than 299 km/h (186 mph) or instrument panel is not receiving the speed value ("- - -" steady on);
- the rear speed sensor is in fault (flashing "- - -").

### Note

If the instrument panel does not receive any information on the unit of measurement, the last unit of measurement set is displayed flashing.

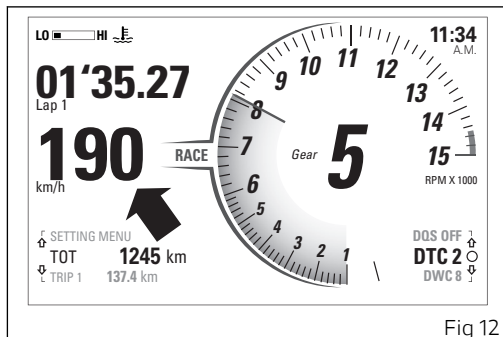

Fig 12

## Gear

The instrument panel receives information about the gear engaged and displays the corresponding value.

If a gear is engaged, the displayed value may range from 1 to 6, while if in neutral N is displayed and the Neutral warning light turns on (warning light 2, see "Instrument panel").

Dash "-" steady and Neutral warning light flashing are displayed (warning light 2, see "Instrument panel") in case of gear sensor fault.

### Note

If the display shows "-" steady on and the Neutral light is off, then the gearbox could be in a mechanically unstable position; in such a case, up/downshift until the correct gear is indicated.

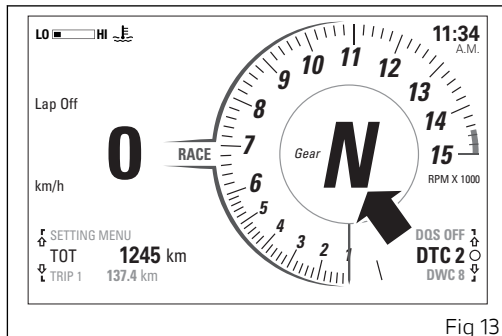

Fig 13

## Clock

The instrument panel shows the time in the following format:

- A.M. (from 12:00 to 11:59) or P.M. (from 12:00 to 11:59).
- hh (hours) : mm (minutes);

In case of a power off (Battery Off), upon the following Key-On, the instrument panel displays 4 dashes "-- : --" steadily and with flashing colon and "A.M." steadily, until clock is set through the Setting Menu.

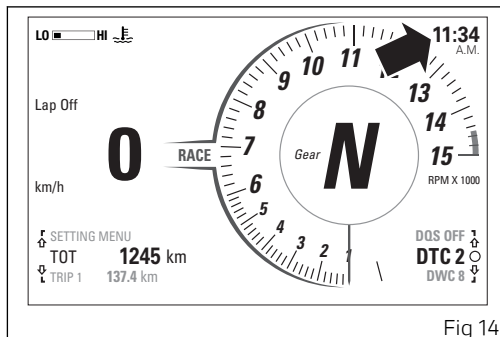

Fig 14

## Engine Coolant temperature

The instrument panel displays the engine temperature value through a graduated scale divided into 5 notches between "LO" and "HI" symbols.

The temperature display range goes from +40°C to +125°C (+104°F ÷ +257°F).

When the temperature is higher than +125°C (+257°F), the graduated scale is replaced by the red flashing "HIGH" message.

### Attention

In case of overheating, if possible, it is recommended to ride at reduced speed to allow the cooling system to lower the engine temperature. If this is not possible due to traffic conditions, stop and turn the engine off.

If the motorcycle continues to be used when the engine is overheated, severe damage may occur.

When the engine temperature returns to normal, continue riding by frequently checking the instrument panel indication.

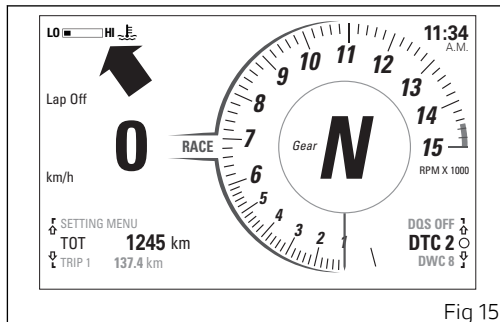

Fig 15

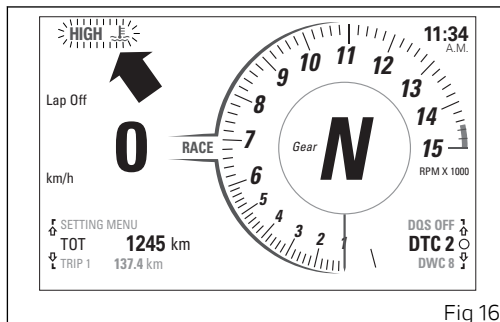

Fig 16

## Riding Mode (RIDING MODE)

The Riding Mode can be selected from the instrument panel. Three preset riding modes are available: RACE, SPORT, STREET.

The selected and active riding mode is displayed in the central part of the display, between the speed value and the rev counter.

### Attention

Ducati recommends changing the Riding mode when the motorcycle is stopped. If the riding mode is changed while riding, be very careful (it is recommended to change the Riding mode at a low speed).

Every Riding Mode contains the following parameters, set by Ducati or customised by the user through the setting function pages:

- a specific engine power that will change throttle behaviour (HIGH, MEDIUM, LOW);
- a specific level of intervention for the DTC traction control (1, 2, 3, 4, 5, 6, 7, 8, OFF);
- a specific ABS calibration (1, 2, 3);
- a specific level of intervention for the DWC (1, 2, 3, 4, 5, 6, 7, 8, OFF);

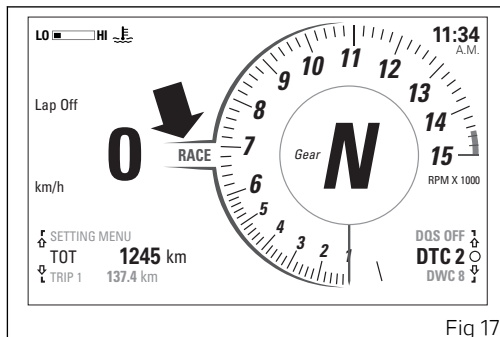

Fig 17

- a specific level of intervention for the DSC control of side slipping of the rear tyre (1, 2, 3, OFF);
- a specific level of intervention of the EBC engine brake control system (1, 2, 3, OFF);
- a specific DQS level (UP/DOWN, OFF)
- a specific mode of intervention of the DES electronic suspension (FIXED, DYNAMIC).

A different standard screen layout (TRACK, ROAD) is associated to every riding mode; it is set by Ducati or customised by the user from the setting function

page; the layouts set by Ducati are associated to the Riding modes as follows:

- TRACK layout for the RACE Riding mode (;
- ROAD layout for the SPORT Riding mode (;
- ROAD layout for the STREET Riding mode (;

## Riding mode change function

This Function allows changing vehicle Riding Modes in static and dynamic conditions. There are four possible riding modes: RACE, SPORT, STREET.

To select the riding mode it is necessary to access the specific Riding Mode Menu by pressing button (4) for 1 second.

The instrument panel displays the speed indication (on the right) and riding mode name (on the left):

- RACE
- SPORT
- STREET

One of these will be highlighted to indicate that it was the last memorised setting and is currently in use. The "EXIT" message is also present: if button (4) is pressed when this application is selected, the instrument panel will quit without memorising the new riding mode.

For the highlighted riding mode some of the parameter settings are displayed:

- engine power (ENGINE): "Engine" lettering followed by set engine power ("High" "Medium" "Low");

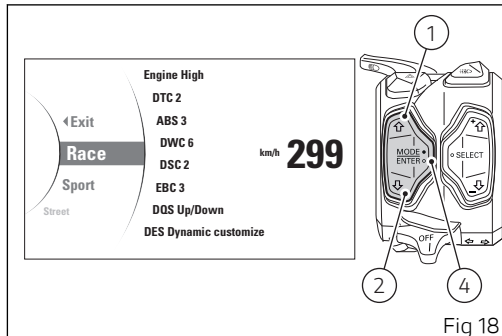

- DTC system: the "DTC" message followed by the level of intervention set ("1", "2", "3", "4", "5", "6", "7", "8") in case the DTC is active or by "off" in case the DTC is disabled;
- ABS system: the "ABS" text followed by the level of calibration set ("1" "2" "3");
- DWC system: the "DWC" message followed by the level of intervention set ("1", "2", "3", "4", "5", "6", "7", "8") in case the DWC is active or by "off" in case the DWC is disabled;

- DSC system: the "DSC" message followed by the level of intervention set ("1" "2" "3") in case the DSC is active or by "off" in case the DSC is disabled;
  - EBC system: "EBC" message followed by the level of intervention set ("1" "2" "3") in case EBC is active or by "off" in case the EBC is disabled;
  - DQS system: the "DQS" message followed by the level of intervention set ("Up/Down") in case the DQS is active or by "off" in case the DQS is disabled.
  - DES system: "DES" message followed by the mode set ("Fixed Suspension" or "Dynamic Suspension").
- RACE; by pressing instead button (1) the instrument panel will highlight " ◀ EXIT", STREET, SPORT to then go back to RACE.
- Once the desired riding mode is selected press button (4) to memorise the new Riding Mode.

The displayed information is the settings stored for every single Riding Mode. The stored settings may be the Ducati default settings or the ones customised by the owner.

Now, every time button (1) or button (2) is pressed the instrument panel scrolls the other Riding Modes (RACE, SPORT, STREET) and " ◀ EXIT". If, for instance, the starting Riding Mode is RACE, by pressing button (2) the instrument panel highlights SPORT, STREET, and " ◀ EXIT" to then go back to

If vehicle speed is lower than or equal to 5 Km/h (3 mph) the instrument panel checks the throttle position only:

- if throttle is "closed", the instrument panel will confirm the selected riding mode, the name of Riding Mode flashes for 3 seconds and instrument panel goes back to "standard page" displaying;
- if throttle is "open" the instrument panel activates the "CLOSE THROTTLE" (A), indication; only when throttle is "closed" the new selected riding mode is confirmed and memorised, and the instrument panel goes back to "standard page" displaying.

If vehicle speed is higher than 5 Km/h (3 mph), the instrument panel checks the throttle position and the front and rear brake pressure:

- if throttle is "closed" and brakes are released or vehicle is stopped, the instrument panel confirms the selected riding mode, the name of the Riding mode flashes for 3 seconds and goes back to "standard page" displaying;

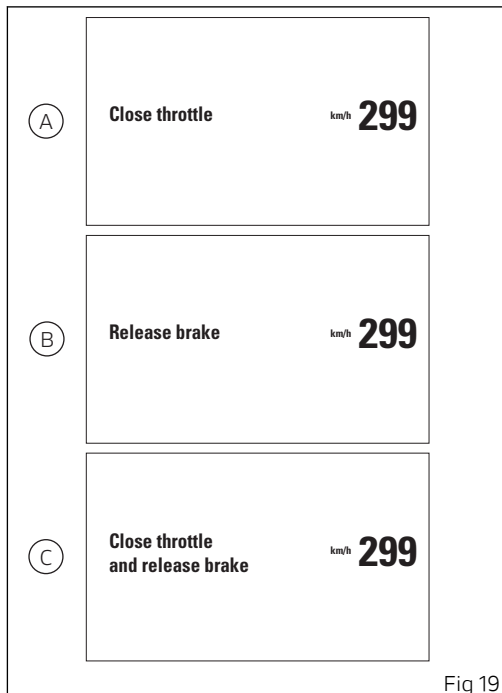

Fig 19

- if throttle is "open" the instrument panel activates the "CLOSE THROTTLE" (A) indication; only when throttle is "closed" the new selected riding mode is confirmed and memorised, and the instrument panel goes back to "standard page" displaying;
- if throttle is "closed" but brakes are operated, the instrument panel activates the "RELEASE BRAKES" (B) indication and only when brakes are released the new selected riding mode is confirmed and memorised, and the instrument panel goes back to standard page displaying;
- if throttle is "open" or if brakes are operated and vehicle is moving, the instrument panel shows "CLOSE THROTTLE AND RELEASE BRAKES" (C) and, only after all conditions are met (closed throttle and brakes released or vehicle stopped) the instrument panel confirms and memorises the new selected riding mode and goes back to "standard page" displaying.

If the above-described conditions for "validating" the change of Riding Mode are not observed within 5 seconds from when "CLOSE THROTTLE" or "RELEASE BRAKES" or "CLOSE THROTTLE AND RELEASE BRAKES" indications, the selection

procedure will be aborted and the instrument panel will go back to displaying the page active before Riding Mode selection started, and no settings will be changed.

If you select "EXIT" and press button (4) (Fig 18), the instrument panel will display the main screen, without storing the new setting (the new Riding Mode).

## Parameter menu and level change

In the lower right corner of the main screen the “Parameter and level change menu” is displayed. This menu features 2 modes:

- Parameter displaying
- Oil change

### Note

Upon next Key-On the “Parameter and level change menu” displays the last mode used before Key-Off.

### Note

In case of battery off, when the voltage is restored and upon next Key-On, the “Parameter and level change menu” displays “Parameter displaying” mode.

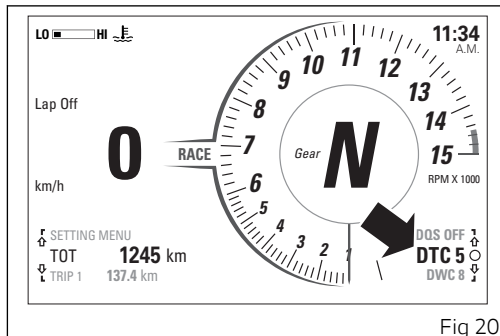





Fig 20

## Parameter displaying

This mode of “Parameter and level change menu” displays the following parameters with the relevant values currently set:

- DTC
- DWC
- DSC
- EBC
- ABS
- DES
- DQS

With button (6)  and button (7)  it is possible to scroll in rotation the list of available parameters. When the empty circle symbol  at the right of the parameter is displayed, it is possible to carry out a level change for that parameter by pressing button (5) .

### Note

If a parameter has been set to “off” through the Setting Menu (e.g. DTC, DWC, DSC, EBC), “off” status is displayed and it is not possible to perform its quick change.

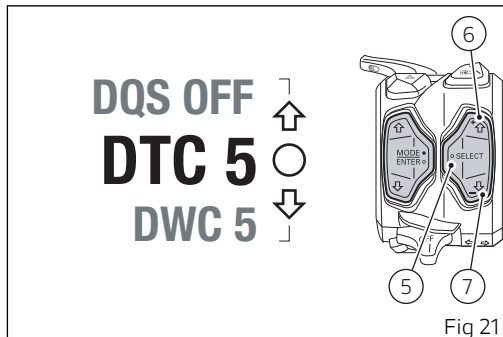

## Oil change



This mode of “Parameter and level change menu” displays the selected parameter and the relevant level currently set, and it is possible to set a new level among the available values.

Parameters for which it is possible perform the quick change are the following:

- DTC (from level 1 to level 8)
- DWC (from level 1 to level 8)
- DSC (from level 1 to level 2)
- EBC (from level 1 to level 3)

In “Parameter displaying” mode, when one parameter listed above is displayed, press button (5)  to

to enter level quick change mode.

The parameter is displayed inside the menu on the left side and it is possible to select the desired level using button (6)  and button (7) .

For example, if the parameter for which you wish to carry out the quick level change is “DTC” and the current level is “5”:

- each time you press the button (7)  it decreases by one level until reaching level “1”;

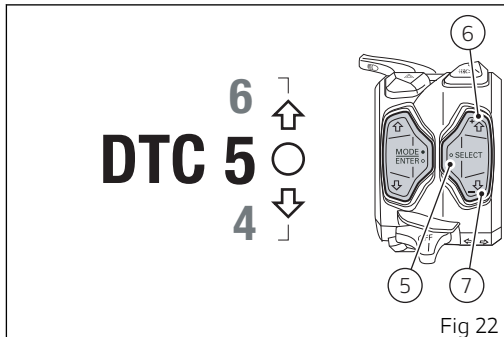

- each time you press the button (6)  it increases by one level until reaching level “8”.

The level displayed is immediately set by the instrument panel for the concerned parameter.



### Note

Through the quick change it is not possible to disable the parameter by setting an “off” level.

Press button (5)  to go back to “Displaying of parameters and relevant values” mode.

## DTC

The instrument panel displays DTC status through the "Parameter and level change menu" page 0 :

- if the DTC is active, the message "DTC" and the set intervention level number "1" to "8";
- if DTC is active, but system is in degraded operation, "DTC" indication and the number, "1" to "8" (flashing); also the DAVC warning light starts flashing (warning light 8, see "Instrument panel").
- when in fault, the "DTC" indication and the red "Err" message;
- if the DTC is disabled, the "DTC" indication and "Off" message; also the DAVC warning light turns on (warning light 8, see "Instrument panel").



### Attention

In case of system malfunction, contact a Ducati Dealer or Authorised Service Centre.

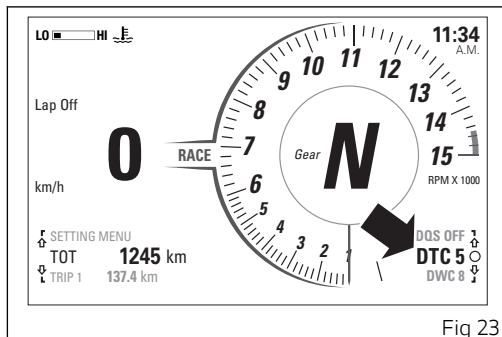

Fig 23



### Attention

DTC is a rider aid that can be used both on the road and on the track. The system is designed to make riding easier and to enhance safety, but in no way relieves the rider of the obligation to drive responsibly and to maintain a high standard of riding in order to avoid accidents, whether caused by his own errors or those of other road users, through making emergency manoeuvres, in accordance with the prescriptions of the road traffic code.

The rider must always be aware that active safety systems have a preventive function. The active elements help the rider control the motorcycle, making it as easy and safe to ride as possible. The presence of an active safety system should not encourage the rider to ride at speeds beyond the reasonable limits, not in accordance with the road conditions, the laws of physics, good riding standards and the requirements of the road traffic code.

The following table indicates the most suitable level of DTC intervention for the various riding modes, as well as the default settings in the "Riding Mode" that can be selected by the rider:

<b>DTC</b>	<b>RIDING MODE</b>	<b>USE</b>	<b>DEFAULT</b>
OFF		The DTC is disabled.	NO
1	TRACK Professional	This level is designed for exclusive track use and for very expert riders. It is optimised for Pirelli tyres with SC1 compound. In this mode, the DTC allows side slipping.	NO
2	TRACK	This level is designed for exclusive track use and for very expert riders. It is optimised for OEM tyres. In this mode, the DTC allows side slipping.	NO
3	SPORT / TRACK	This level is designed for track use and for expert riders. In this mode, the DTC allows side slipping.	It is the default level for the "RACE" Riding Mode
4	SPORT / TRACK	This level is designed for track use (and road use, for expert riders).	

<b>DTC</b>	<b>RIDING MODE</b>	<b>USE</b>	<b>DEFAULT</b>
5	SPORT	This level is designed for riding on the road or on the track, consistent with ENGINE LOW operation.	It is the default level for the "SPORT" Riding Mode
6	SAFE & STABLE	This level is designed for use in any riding conditions, on the road with good grip.	It is the default level for the "STREET" Riding Mode
7	RAIN	This level is designed for track use, exclusively with Rain tyres when surface is wet.	NO
8	HEAVY RAIN	This level is designed for road use, when surface is wet and very slippery. ENGINE LOW must be used for an optimum operation of this level.	NO

## Tips on how to select the sensitivity level



### Attention

Excellent operation of the DTC system, for all available levels, is ensured only with OE tyres and/or with the ones recommended by Ducati and with the OE final drive ratio. In particular, OE tyres for this motorcycle are Pirelli Diablo Supercorsa SP in the following sizes: 120/70ZR17 at the front, 200/60ZR17 at the rear. The use of tyres of different size and characteristics to the original tyres may alter the operating characteristics of the system thus making it unsafe. It is recommended not to install tyres of different size than the ones approved for your vehicle.

As far as tyres are concerned, in the case of minor differences such as, for example, tyres of a different make and/or model than the OE ones, it is necessary to use the relevant automatic calibration function in order to restore correct system operation.

As far as the final ratio is concerned, when using a different ratio (which is only possible for tracing use) than the original equipment one, it is recommended

to use the relevant automatic calibration function in order to restore optimal system operation.

If level 8 is selected, the DTC will kick in at the slightest hint that the rear wheel is starting to spin. Between level 8 and level 1 there are other 6 intermediate levels. DTC intervention gradually decreases from level 8 to level 1.

Level 1 is specifically designed for track use with SC1 compound tyres (Pirelli Diablo Supercorsa SC1) that are not the OE ones for this motorcycle. The use of this level with tyres having different characteristics may alter the operating characteristics of the system.

The choice of the correct level depends on 3 main variables:

- 1) The grip (type of tyre, amount of tyre wear, the road/track surface, weather conditions, etc.)
- 2) The characteristics of the path/circuit (bends all taken at similar speeds or at very different speeds)
- 3) The riding mode (whether the rider has a "smooth" or a "rough" style)

Level depends on grip conditions

The choice of level setting depends greatly on the grip conditions of the track/path (see below, tips for use on the track and on the road). Poor grip requires a higher level that ensures a more aggressive DTC intervention.

### Level depends on type of track

If the track/path features bends all taken at similar speeds, it will be easier to find a level suitable for all bends; while a track/path with bends all requiring different speeds will require a DTC level setting that is the best compromise for all bends.

### Level depends on riding style

The DTC will tend to kick in more with a "smooth" riding style, where the motorcycle is leaned over further, rather than with a "rough" style" where the motorcycle is straightened up as quickly as possible when exiting a turn.

### Tips for use on the track

We recommend that level 6 is used for a couple of full laps in order to heat the tyres and get used to the system. Then try levels 6, 5, 4, etc., in succession until you identify the DTC sensitivity level that suits you best.

Once you have found a satisfactory setting for all the corners except one or two slow ones, where the system tends to kick in and control too much, you can try to modify your riding style slightly to a more "rough" approach to cornering i.e. straighten up more rapidly on exiting the corner, instead of immediately trying a different level setting.

### Tips for use on the road

We recommend level 8 be used in order to get used to the system. If the level of DTC intervention seems aggressive, try reducing the setting to levels 5, 4, etc. until you find the level that suits you best.

If changes occur in the grip conditions and/or circuit characteristics and/or your riding style, and the level setting is no longer suitable, switch to the next level up or down and proceed to determine the best setting (e.g. if with level 7 the DTC intervention seems excessive, switch to level 6; alternatively, if on level 7 you cannot perceive any DTC intervention, switch to level 8).

## DWC

The instrument panel displays DWC status through the "Parameter menu and level change" page 0 :

- if the DWC is active, the message "DWC" and the set intervention level number "1" to "8";
- if DWC is active, but system is in degraded operation, the "DWC" indication and the number, "1" to "8" (flashing); also the DAVC warning light starts flashing (warning light 8, see "Instrument panel");
- when in fault, the "DWC" indication, the red "Err" message; also the DAVC warning light turns on (warning light 8, see "Instrument panel").
- if DWC is disabled, "DWC" "OFF" indication;

### Attention

In case of system malfunction, contact a Ducati Dealer or Authorised Service Centre.

### Note

If DTC is set to OFF, DWC is also forced to OFF.

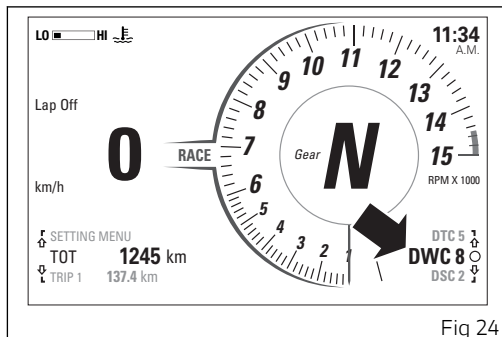

Fig 24

The Ducati Wheelie Control system (DWC) supervises control of wheelie movement and settings vary through eight different levels that are calibrated to offer a different prevention and reaction to wheelies. Each Riding Mode features a pre-set intervention level. Level eight indicates a setting that minimises motorcycle tendency to shift up in a wheelie and maximises reaction to the same, if it occurs. While level one is for expert riders and features a lower wheelie control in terms of prevention and less strong reaction to the same, if it occurs.



## Attention

DWC is a rider aid that can be used on both the track and the road. The system is designed to make riding easier and to enhance safety, but in no way relieves the rider of the obligation to drive responsibly and to maintain a high standard of riding in order to avoid accidents, whether caused by his own errors or those of other road users, through making emergency manoeuvres, in accordance with the prescriptions of the road traffic code.

The rider must always be aware that active safety systems have a preventive function. The active elements help the rider control the motorcycle, making it as easy and safe to ride as possible. The presence of an active safety system should not encourage the rider to ride at speeds beyond the reasonable limits, not in accordance with the road conditions, the laws of physics, good riding standards and the requirements of the road traffic code.

The following table indicates the most suitable level of DWC intervention for the various riding types as well as the default settings in the "Riding Mode" that can be selected by the rider:

<b>DWC</b>	<b>USE</b>		<b>DEFAULT</b>
OFF		The DWC is disabled.	NO
1	HIGH PERFORMANCE	Track use for expert riders. The system allows wheelies, but decreases the speed at which the front wheel lifts.	NO
2	MEDIUM PERFORMANCE	Track use for expert riders. The system allows wheelies, but decreases the speed at which the front wheel lifts.	NO
3	PERFORMANCE	Track use for expert riders. The system allows wheelies, but decreases the speed at which the front wheel lifts.	It is the default level for the "RACE" Riding Mode
4	PERFORMANCE	Track use for all kinds of riders. The system allows wheelies, but decreases the speed at which the front wheel lifts.	It is the default level for the "SPORT" Riding Mode
5	SPORT	Level for all kinds of riders. The system reduces the motorcycle's proneness to do wheelies and sensitively intervenes in case of wheelie.	It is the default level for the "STREET" Riding Mode

DWC	USE		DEFAULT
6	SPORT	Level for all kinds of riders. The system reduces the motorcycle's proneness to do wheelies and sensitively intervenes in case of wheelie.	NO
7	MEDIUM SAFE & STABLE	Level for all kinds of riders. The system reduces the motorcycle's proneness to do wheelies and sensitively intervenes in case of wheelie.	NO
8	HIGH SAFE & STABLE	Level for all kinds of riders. The system reduces the motorcycle's proneness to do wheelies to a minimum level and sensitively intervenes in case of wheelie.	NO

## Tips on how to select the sensitivity level



### Attention

Excellent operation of the DWC system, for all available levels, is ensured only with the OE final drive ratio and with OE tyres and/or with the ones recommended by Ducati. In particular, OE tyres for this motorcycle are Pirelli Diablo Supercorsa SP in the following sizes: 120/70ZR17 at the front, 200/60ZR17 at the rear. The use of tyres of different size and characteristics to the original tyres may alter the operating characteristics of the system thus making it unsafe. It is recommended not to install tyres of different size than the ones approved for your vehicle.

As far as the final ratio is concerned, when using a different ratio (which only possible for tracing use) than the original equipment one, it is recommended to use the relevant automatic calibration function in order to restore optimal system operation.

At level 8 the DWC system reduces the motorcycle's proneness to do wheelies to a minimum level and sensitively intervenes in case of wheelie. Between level 8 and level 1 there are further intermediate

levels of intervention for the DWC. Levels 1, 2 and 3 allow easier wheelies, but reduce their speed: these levels are recommended only for track use and for expert riders who can control wheelies on their own and exploit the system feature that reduces the speed at which the front wheel tends to lift.

The choice of the correct level mainly depends on the following parameters:

- The rider's experience;
- The characteristics of the path/circuit (bend exit with low or high gear engaged).

### The rider's experience

The choice of level setting depends greatly on the riders' experience and ability to control wheelies on their own. Levels 1, 2 and 3 require a great experience to ensure proper control.

### Level depends on type of track

If the track/path features bends where out speed and gear are low, a lower level will be necessary; while a track/path with faster bends will allow the use of a higher level setting.

### Tips for use on the track

We recommend to use level 8 for a couple of full laps in order to get used to the system. Then try levels 7, 6, etc., in succession until you identify the DWC sensitivity level that suits you best (always try each level for at least two laps to allow the tyres to warm up).

### Tips for use on the road

Activate the DWC, select level 8 and ride the motorcycle in your usual style; if the level of DWC sensitivity seems excessive, try levels 7, 6, etc., until you find the one that suits you best. If changes occur in the circuit characteristics, and the level setting is no longer suitable, switch to the next level up or down and proceed to determine the best setting (e.g. if with level 7 the DWC intervention seems excessive, switch to level 6; alternatively, if on level 7 you cannot perceive any DWC intervention, switch to level 8).

## DSC

The instrument panel displays DSC status through the "Parameter and level change menu" page 0 :

- if the DSC is active, the "DSC" indication and the set intervention level number "1" to "2";
- if DSC is active, but system is in degraded operation, the "DSC" indication and the number, "1" to "2" (flashing); also the DAVC warning light starts flashing (warning light 8, see "Instrument panel");
- when in fault, the "DSC" indication and the red "Err" message;
- if the DSC is disabled, the "DSC" indication and "OFF" message; also the DAVC warning light turns on (warning light 8, see "Instrument panel").

### Attention

In case of system malfunction, contact a Ducati Dealer or Authorised Service Centre.

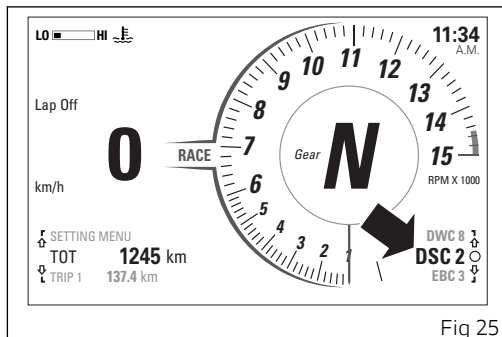

Fig 25



### Note

If DTC is set to OFF, DSC is also forced to OFF.

The Ducati Slide Control (DSC) system assists the rider during the acceleration when exiting a curve in order to better control the side slipping of the rear wheel. The system thus improves the intervention of the single DTC function that works on the tyre longitudinal slipping providing better assistance in extreme riding conditions.

The DSC system works on 2 different levels, each calibrated to offer a different intervention on the

side slipping of the tyre in combination with a specific DTC level.

The rider must always be aware that active safety systems have a preventive function. The active elements help the rider control the motorcycle, making it as easy and safe to ride as possible. The presence of an active safety system should not encourage the rider to ride at speeds beyond the reasonable limits, not in accordance with the road conditions, the laws of physics, good riding standards and the requirements of the road traffic code.

The following table indicates the most suitable DSC intervention level depending on the riding modes. Depending on the selected DTC level, the different levels are optimized for tyres and the indicated DTC levels.

DSC	USE	DEFAULT
OFF	The DSC is disabled.	NO
1	The basic intervention level depends on the selected DTC level. The DSC system increases the intervention extent in a limited way in order limit side slipping.	NO
2	The basic intervention level depends on the selected DTC level. The DSC system increases the intervention extent in a more significant way in order limit side slipping.	It is the default level for the "RACE", "SPORT" and "STREET" Riding Modes.



### Attention

The DSC system assists the rider in the control of the rear tyre side slipping and facilitates the acceleration out of curves. Therefore, the system does not prevent the rider from reaching potentially dangerous leaning angles and for safety reasons it must be used with due riding care.

## Tips on how to select the intervention level

According to the riding style, the curve-exit phase can be performed in a rougher or smoother way and can lead to different leaning angles. Therefore, it is suitable to follow the indications provided below to identify the intervention level most appropriate for your riding style.

To this end, we recommend to identify first the most suitable DTC level according to the indications provided in the DTC system description. Then, we recommend selecting the DSC 2 level, i.e. the most invasive intervention, and ride some laps to become familiar with the system. If the system intervention on the lateral grip is too strong, we recommend trying DSC 1 level, associated to a softer intervention.

If non-OEM tyres of a different size class are used or if the tyre size differs significantly from the original tyres, it may be that the system operation is compromised.

As far as tyres are concerned, in the case of minor differences such as, for example, tyres of a different make and/or model than the OE ones, it is necessary to use the relevant automatic calibration function in order to restore correct system operation.



## Attention

The DSC is a rider assist system. The system is designed to make riding easier and to enhance safety, but in no way relieves the rider of the obligation to drive responsibly and to maintain a high standard of riding in order to avoid accidents, whether caused by his own errors or those of other road users, through making emergency manoeuvres, in accordance with the prescriptions of the road traffic code.

The rider must always be aware that active safety systems have a preventive function. The active elements help the rider control the motorcycle, making it as easy and safe to ride as possible. The presence of an active safety system should not encourage the rider to ride at speeds beyond the reasonable limits, not in accordance with the road conditions, the laws of physics, good riding standards and the requirements of the road traffic code.

## EBC

The instrument panel displays EBC status through the "Parameter and level change menu" page 0 :

- if the EBC is active, the message "EBC" with the set intervention level number (1 to 3);
- If EBC is active, but system is in degraded operation, "EBC" message and the number, "1" to "3" (flashing);
- when in fault, the "EBC" indication and the red "Err" message;
- if EBC is disabled, "DTC" and "Off" indication.

The Engine Braking Control (EBC) system controls engine braking when riding with throttle control completely closed (both when downshifting and in a normal cut-off with the same gear engaged, while braking or not). This system independently adjusts the throttle valves to ensure a consistent torque goes back from the wheel to engine during these stages.

The system allows the rider to set "engine brake", the range being from a maximum engine braking with system set to OFF and progressively decreasing as level increases.

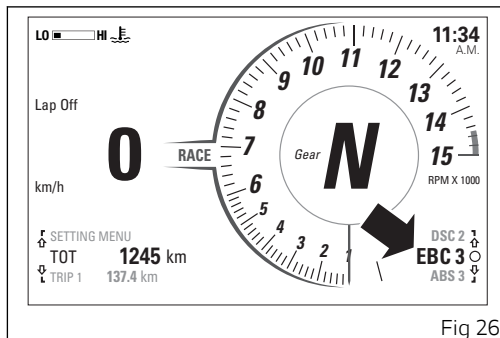

Fig 26

System is particularly sensitive at high rpm and sensitivity gradually decreases as soon as engine rpm decrease.



## Attention

EBC is a rider aid that can be used both on the track and the road. The system is designed to make riding easier, but in no way relieves the rider of the obligation to ride responsibly and to maintain a high standard of riding in order to avoid accidents, whether caused by his own errors or those of other road users, through making emergency manoeuvres, in accordance with the prescriptions of the road traffic code.

The following table indicates the most suitable level of EBC intervention for the various riding modes as well as the default settings in the "Riding Modes" that can be selected by the rider:

<b>EBC</b>	<b>CHARACTERISTIC</b>	<b>DEFAULT</b>
OFF	The EBC is disabled. The engine delivers maximum engine brake.	NO
1	In this level the engine delivers a considerable engine brake, but lower than the one that can be obtained with EBC OFF.	NO
2	In this level the engine delivers a poor engine brake. This level is recommended to any rider requiring reduced engine braking in deceleration.	It is the default level for the RACE and SPORT Riding Modes.
3	In this level the engine delivers the least engine brake. This level is recommended to any rider requiring very low engine braking in deceleration.	It is the default level for the STREET Riding Mode.

## Tips on how to select the sensitivity level



### Attention

Excellent operation of the EBC system, for all available levels, is ensured only with OE tyres and/or with the ones recommended by Ducati and with the OE final drive ratio. In particular, OE tyres for this motorcycle are Pirelli Diablo Supercorsa SP in the following sizes: 120/70ZR17 at the front, 200/60 ZR17 at the rear. The use of tyres of different size and characteristics to the original tyres may alter the operating characteristics of the system thus making it unsafe. It is recommended not to install tyres of different size than the ones approved for your vehicle.

As far as tyres are concerned, in the case of minor differences such as, for example, tyres of a different make and/or model than the OE ones, it is necessary to use the relevant automatic calibration function in order to restore correct system operation.

As far as the final ratio is concerned, when using a different ratio (which only possible for tracing use) than the original equipment one, it is recommended

to use the relevant automatic calibration function in order to restore optimal system operation.

Selecting level 3, the EBC will kick in to ensure the minimum engine brake possible. Between level 3 and level 1 the engine brake levels are increasing progressively; with EBC OFF you set the maximum engine brake level possible.

The choice of the correct level mainly depends on the following parameters:

- The grip (type of tyre, amount of tyre wear, the road/track surface, weather conditions, etc.).
- The characteristics of the path/circuit (bends all taken at similar speeds or at very different speeds).
- The Riding Mode.

## Level depends on grip conditions

The choice of level setting depends greatly on the grip conditions of the track/circuit.

## Level depends on type of track

If the track/path requires consistent braking (always aggressive or always smooth), it will be easier to find a level suitable for all braking instances; while a track/path requiring different braking power will require an EBC system level setting that is the best compromise for all instances.

## ABS

The instrument panel displays ABS status through the "Parameter and level change menu" page 0 :

- the message "ABS" and the set intervention level number "1" to "3";
- if ABS is in degraded operation due to a fault (no "cornering" feature), "ABS" message and the set intervention level number "1" to "3" (flashing); also the ABS warning light (10, starts flashing);
- when in fault, the "ABS" indication, the red "Err" message; also the ABS warning light (10, turns on);

### Attention

In case of system malfunction, contact a Ducati Dealer or Authorised Service Centre.

Using the brakes correctly under adverse conditions is the hardest – and yet the most critical – skill to master for a rider. Braking is one of the most difficult and dangerous moments when riding a two wheeled motorcycle: the possibility of falling or having an accident during this difficult moment is statistically

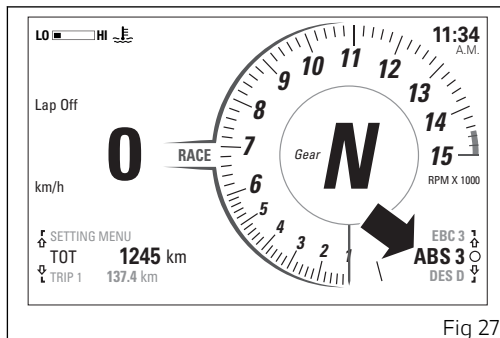

Fig 27

higher than any other moment. A locked front wheel leads to loss of traction and stability, resulting in loss of control.

The Anti-Lock Braking System (ABS) has been developed to enable riders to use the motorcycle braking force to the fullest possible amount in emergency braking or under poor pavement or adverse weather conditions. ABS is an electro-hydraulic device that controls the pressure in the brake circuit when the control unit, by processing information from wheel sensors, determines that one or both wheels are about to lock up. In this case,

pressure decrease in the brake circuit allows the wheel to carry on turning, thereby preserving grip. After that, the control unit restores the pressure in the brake circuit, to resume the braking action. This cycle is repeated many times until the problem is completely eliminated. Normally, the rider will perceive ABS operation as a harder feel or a pulsation of the brake lever and pedal. The front and rear brakes use separate control systems.

The ABS system fitted to the Panigale V4 is a safety system preventing wheel lockup while braking, adopting different strategies depending on the selected level. The active presence of strategies and their intervention level depend on the selected level. The ABS features 3 levels, one associated to each Riding Mode.

The Panigale V4 ABS features a "cornering" function that optimises ABS functionality to the conditions where the motorcycle is leaning over, thus preventing wheel lockup and slipping as much as possible, within the physical limits allowed by the vehicle and by the road conditions. The cornering function is active on all the ABS levels.

According to the selected level, the Panigale V4 ABS can implement the anti lift-up function for the rear

wheel so as to guarantee not only a reduced stopping distance under braking, but also the highest possible stability.

In ABS level 1, associated by default to RACE Riding Mode, the system only works on the front discs to ensure top performance for track use. Also in this mode the cornering function is active: its level of intervention is described below.

In ABS level 2, associated by default to SPORT Riding Mode, also the DSC control (slide control under braking) is active. Under some activation conditions, ensuring in any case the maximum rider safety, the ABS system allows more pronounced slipping at the rear allowing vehicle yaw or slide, so as to permit a more sporty and faster corner entry. This control activates when the user acts on the rear brake during a sufficiently strong braking also at the front. During the operation of this system, the ABS monitors vehicle slipping or slide level, so that it remains below a safety level, which depends on the lean angle. If vehicle slipping or slide level increases too much, the ABS operates again in standard mode, realigning the vehicle in order to always ensure the maximum safety.



## Attention

Using the two brake controls separately reduces the motorcycle braking power. Never use the brake controls harshly or suddenly as you may cause rear wheel lift-up and lose control of the motorcycle. When riding in the rain or on slippery surfaces, braking will become less effective. Always use the brakes very gently and carefully when riding under these conditions. Any sudden manoeuvres may lead to loss of control. When tackling long, high-gradient downhill road tracts, shift down gears to use engine braking. Apply one brake at a time and use brakes sparingly. Keeping the brakes applied all the time would cause the friction material to overheat and reduce braking power dangerously. Underinflated and overinflated tyres reduce braking efficiency, handling accuracy and stability in a bend.

The following table indicates the most suitable level of ABS intervention for the various riding types as well as the default settings in the "Riding Mode" that can be selected by the rider:

<b>ABS</b>	<b>RIDING MODE</b>	<b>CHARACTERISTIC</b>	<b>DEFAULT</b>
1	TRACK	This level is designed exclusively for track use, for expert riders (not recommended for road use). ABS in this level only controls the front wheel, and thus allows rear wheel lockup. The system in this level does NOT control the lift-up. While cornering function is active.	It is the default level for the "RACE" Riding Mode
2	SPORT	This level is designed for use when riding on the road and on the track, with good grip conditions. ABS in this level controls both wheels and the cornering function is active. In this level system does NOT control lift-up: this calibration focuses on braking power and wheel lift-up should be managed by the rider. In this level, also the DSC (slide control under braking) is active.	It is the default level for the "SPORT" Riding Mode

ABS	RIDING MODE	CHARACTERISTIC	DEFAULT
3	SAFE & STABLE	This level is designed for use in any riding conditions to provide a safe and consistent braking action. ABS in this level controls both wheels and the cornering and anti-lift-up functions are active.	It is the default level for the "STREET" Riding Mode

## Tips on how to select the sensitivity level



### Attention

Excellent operation of the ABS system, for all available levels, is ensured only with the OE brake system and with OE tyres and/or with the ones recommended by Ducati. In particular, OE Tyres for this motorcycle are Pirelli Diablo Supercorsa SP in the following sizes: 120/70 ZR17 at the front, 200/60 ZR17 at the rear. The use of tyres of different size and characteristics to the original tyres may alter the operating characteristics of the system thus making it unsafe. It is recommended not to install tyres of different size than the ones approved for your vehicle.

Selecting level 3, the ABS will ensure a very stable braking thanks to lift-up control, and the motorcycle will keep a good alignment during the whole braking action. ABS level 3 features active cornering function which, with vehicle leaning over, prevents wheel lockup and slipping as much as possible, within the physical limits allowed by the vehicle and by the road conditions.

Selecting level 2, the ABS will privilege more and more the braking power rather than stability and lift-up control, which is disabled in level 2. ABS level 2 features active cornering function which, with vehicle leaning over, prevents wheel lockup and slipping as much as possible, within the physical limits allowed by the vehicle and by the road conditions. Moreover, level 2 activates the DSC function (available in this level only).

ABS level 1 is specific for track use and ABS is active only on the front wheel to help performance. In this level there is no lift-up control, but the cornering feature remains active.

The choice of the correct level mainly depends on the following parameters:

- 1) The tyre/road grip (type of tyre, amount of tyre wear, the road/track surface, weather conditions, etc.).
- 2) The rider's experience and sensitivity: expert riders can tackle a lift-up in trying to reduce the stopping distance to a minimum, while less expert riders are recommended to use setting 3, that will help them keeping the motorcycle more stable even in emergency braking.

## DES

The instrument panel displays DES status through the "Parameter and level change menu" page 0 :

- if DES is in Dynamic mode, "DES D" indication;
- if DES is in Fixed mode, "DES F" indication;
- if DES is in degraded operation, flashing "DES D" indication if in Dynamic mode or flashing "DES F" indication if in Fixed mode;
- when in fault, the "DES" indication and the red "Err" message;
- if DES is in initialisation phase, flashing "DES -" indication.

This system communicates with the Bosch inertial platform to dynamically respond to changing road and riding conditions, thereby ensuring the best possible damping performance and total control of the motorcycle. It features two operating modes: Fixed, which is not an active mode and allows the rider to set specific compression and rebound settings for the front and rear suspensions (as well as

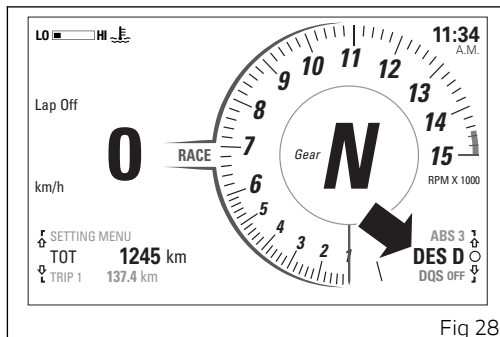

Fig 28

the steering damper preload). These settings are maintained steady by the system until rider changes them, as it happens on a suspension system with standard adjustment. As an alternative, system features the Event Based mode, which is semi-active and allows the rider to select suspension "behaviour" levels, from hard to soft. In this mode, system dynamically adjusts compression, rebound and hardness of the damper depending on riding conditions, while still keeping to the overall "behaviour" level previously selected by the rider.



- Ducati Quick Shift provides no assistance for the gearshift if the rider uses the clutch lever: the Ducati Quick Shift does not work when the clutch lever is pulled.
- Ducati Quick Shift will shift down only when the throttle control is completely closed.
- If the Ducati Quick Shift strategy does not work it is always possible to complete the gear shifting using the clutch lever.
- If the gear lever is held pressed up or down for more than 30 seconds (even if just by accident) a plausibility error can be memorised in the electronic control unit and the Ducati Quick Shift system could be disabled; in this case, a simple key-off and key-on cycle will reactivate the system.
- Ducati Quick Shift is designed to operate above 2,500 rpm.
- No matter the gear engaged, downshifting with Ducati Quick Shift only works below a set threshold, so as to avoid exceeding the maximum rpm allowed when the lower gear is engaged.

## Function menu

From the main screen, press button (1) or (2) on LH switch to scroll through Function Menu.

Whenever button (1) is pressed, instrument panel will increase the "position" (from first position to last position, and back to the first one). Whenever button (2) is pressed, instrument panel will decrease the "position" (from last position to first position, and back to the last one).

In Function Menu box, on the LH side, are the UP

↑ and DOWN ↓ arrows - corresponding to button (1) and button (2) on LH switch - indicating the chance to scroll through the functions. The

empty circle symbol ○ is displayed when it is possible to interact with the displayed function by pressing button (4) on LH switch, for instance to reset trip meter 1 (TRIP 1, page 89).

Based on the set Info Mode and Riding Mode, the Function Menu can display different functions.

All functions available in the Function Menu are:

- Odometer (TOT)
- Trip meter 1 (TRIP 1)
- Average Fuel Consumption (CONS. AVG 1)
- Average speed (SPEED AVG 1)

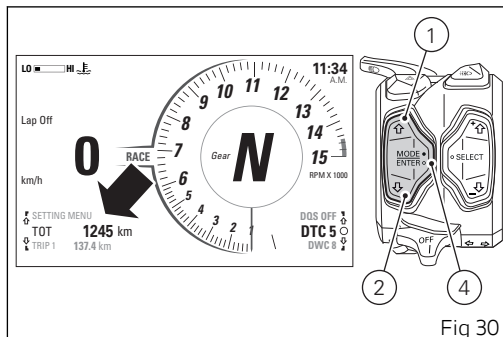

Fig 30

- Trip time (TRIP 1 TIME)
- Ambient air temperature (T AIR)
- Partial fuel reserve counter (TRIP FUEL)
- Trip meter 2 (TRIP 2)
- Instantaneous fuel consumption (CONS. I.)
- Lap time disabling/enabling (LAP Off / On) visible in TRACK info mode only (
- Player management disabling/enabling (PLAYER Off / On) only if BT module is available and a smartphone is connected; visible in ROAD info mode only (

- Call management (LAST CALLS)  
only if BT module is available and a smartphone  
is connected; visible in ROAD info mode only (
- Setting menu (SETTING MENU)

## Odometer (TOT)

To select this function in the Function Menu, scroll the functions available using buttons (1) and (2) to display "TOT".

The odometer counts and displays the total distance covered by the motorcycle with the set unit of measurement (km or mi).

The odometer number (in km or miles) is displayed with the message TOT and the indication of the unit of measurement. When the maximum value is reached (199999 km or 199999 mi) the instrument panel will permanently display said value.

The odometer value is saved permanently and cannot be reset under any circumstances.

The reading is not lost in case of a power OFF (Battery OFF).

### Note

If a string of flashing dashes " ---- " is displayed within odometer function, please contact a Ducati Dealer or Authorised Service Centre.

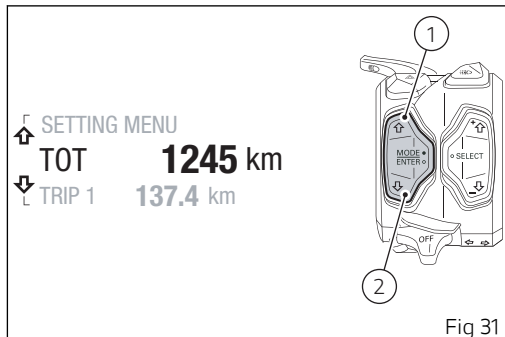

## Trip meter 1 (TRIP 1)

To select this function in the Function Menu, scroll the functions available using buttons (1) and (2) to display "TRIP 1".

The trip meter counts and displays the partial distance covered by the motorcycle with the set unit of measurement (km or mi) and is used as a basis to calculate average fuel consumption, average speed and trip time. The mi or km value for TRIP 1 is displayed with the "TRIP 1" indication and unit of measurement.

When the reading exceeds the maximum value of 9999.9 mi or 9999.9 km, distance is reset and the meter automatically starts counting from 0 again.

If button (4) is pressed when trip meter is displayed, the instrument panel will activate the warning "TRIP 1 RESET ?" in place of the value and unit of measurement. When this warning is active, Function Menu scrolling is not possible.

If you press button (1) or (2), the instrument panel will display TRIP 1 again, without resetting the value. While if you press button (4), value for TRIP 1 will be reset and the instrument panel will display TRIP 1 at "0.0" followed by set unit of measurement.

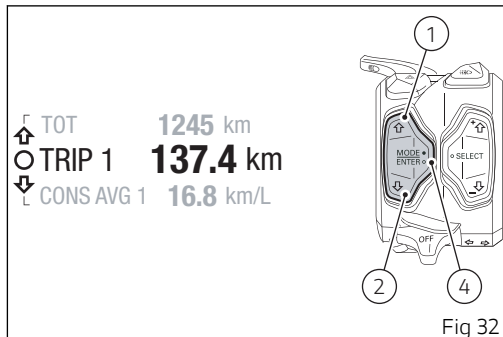

When TRIP 1 is reset, the Average Fuel Consumption (CONS. AVG 1), Average Speed (SPEED AVG 1) and Trip Time (TRIP 1 TIME) are reset as well.

The TRIP 1 counter is automatically reset also in the following cases:

- when Trip time (TRIP 1 TIME) is reset;
- when Average Fuel Consumption (CONS. AVG 1) is reset;
- due to a battery disconnection (Battery-Off);

- in case of manual change of the units of measurement of the system.

## Average Fuel Consumption (CONS. AVG 1)

To select this function in the Function Menu, scroll the functions available using buttons (1) and (2) to display "CONS. AVG 1".

The instrument panel calculates and shows vehicle average fuel consumption.

The average consumption is displayed with the indication "CONS. AVG 1" and the indication of the unit of measurement (km/l or l/100 km or mpg UK or mpg US).

The calculation is made considering the quantity of fuel used and the distance travelled since TRIP 1 was last reset.

When TRIP 1 is reset, the value is reset and the first value available is displayed 10 seconds after the reset. During the first 10 seconds when the value is not available, on the display, three steady dashes "- . -" steadily as average fuel consumption.

The active calculation phase occurs when the engine is running, even when the vehicle is stopped. Moments when the vehicle is not moving and the engine is off are not considered.

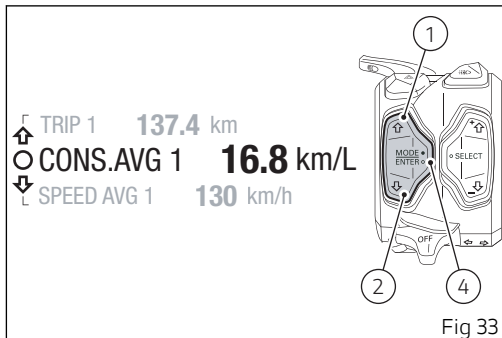

If button (4) is pressed when average fuel consumption is displayed, the instrument panel will activate the warning "CONS.AVG 1 RESET ?" in place of the value and unit of measurement. When this warning is active, Function Menu scrolling is not possible.

If you press button (1) or (2), the instrument panel will display CONS. AVG. 1 again, without resetting the value.

If button (4) is pressed, the value of CONS. AVG 1 is reset and the instrument panel will display CONS. AVG 1 with "0.0" and the set unit of measurement.

When average fuel consumption is reset, during the first 10 seconds when the value is not available on the display, three dashes " - - - " are shown. -".

When CONS. AVG 1 is reset, the data of the Trip meter 1 (TRIP 1), Average Speed (SPEED AVG 1) and Trip Time (TRIP 1 TIME) are reset as well.

The CONS. AVG 1 counter is automatically reset also in the following cases:

- when Trip time (TRIP 1 TIME) is reset;
- when Trip meter 1 (TRIP 1) is reset;
- due to a battery disconnection (Battery-Off);
- in case of manual change of the units of measurement of the system.



## Note

It is possible to change the units of measurement for "Consumption" (both average and instantaneous together) through the Setting MENU, using the UNITS function.

## Average speed (SPEED AVG 1)

To select this function in the Function Menu, scroll the functions available using buttons (1) and (2) to display "SPEED AVG. 1".

The instrument panel calculates and shows vehicle average speed

Vehicle average speed is displayed with the "SPEED AVG. 1" indication and unit of measurement (km/h or mph).

The average speed value displayed is calculated by adding 5% so as to be consistent with motorcycle speed indication.

The calculation considers the distance and time since TRIP 1 was last reset. When TRIP 1 is reset, the value is reset and the first value available is displayed 10 seconds after the reset. During the first 10 seconds, when the value is not yet available, the display will show a string of three dashes " - - - " steadily as average speed.

The active calculation phase occurs when the engine is running, even when the vehicle is stopped. Moments when the vehicle is not moving and the engine is off are not considered.

If button (4) is pressed when average speed is displayed, the instrument panel will activate the

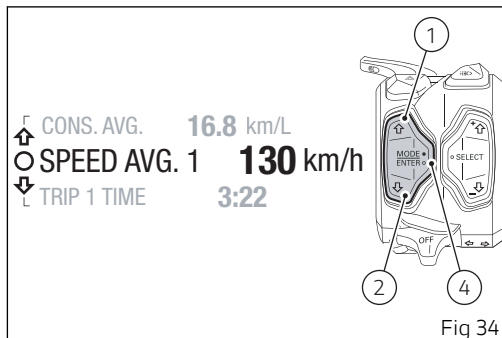

Fig 34

warning "SPEED AVG 1 RESET ?" in place of the value and unit of measurement. When this warning is active, Function Menu scrolling is not possible. If you press button (1) or (2), the instrument panel will display SPEED AVG. 1 again, without resetting the value.

If button (4) is pressed, the value of SPEED AVG. 1 is reset and the instrument panel will display SPEED AVG. 1 with "0" and the set unit of measurement.

When average speed is reset, during the first 10 seconds when the value is not available on the display, three steady dashes " - - - " are shown.

When SPEED AVG. 1 is reset, also Trip meter 1 (TRIP 1), Average Fuel Consumption (CONS. AVG 1) and Trip time (TRIP 1 TIME) data are reset.

SPEED AVG. 1 counter is automatically reset also in the following cases:

- when Trip time (TRIP 1 TIME) is reset;
- when Trip meter 1 (TRIP 1) is reset;
- when Average Fuel Consumption (CONS. AVG 1) is reset;
- due to a battery disconnection (Battery-Off);
- in case of manual change of the units of measurement of the system.

## Trip time (TRIP 1 TIME)

To select this function in the Function Menu, scroll the functions available using buttons (1) and (2) to display "TRIP 1 TIME".

The instrument panel calculates and shows trip time. Value is displayed as hhh:mm followed by "TRIP 1 TIME" indication.

The calculation considers the time since Trip meter 1 (TRIP 1), Average Fuel Consumption (CONS. AVG 1) and Average speed (SPEED AVG 1) were last reset.

The active time counting phase occurs when the engine is running, even when the vehicle is stopped. The time count is automatically stopped when the vehicle is not moving and the engine is off and restarts when the counting active phase starts again.

When the reading exceeds 511:00 (511 hours and 00 minutes), the meter is reset and automatically starts counting from 0 again.

If button (4) is pressed when trip time is displayed, the instrument panel will activate the warning "TRIP 1 TIME RESET ?" in place of the time. When this warning is active, Function Menu scrolling is not possible.

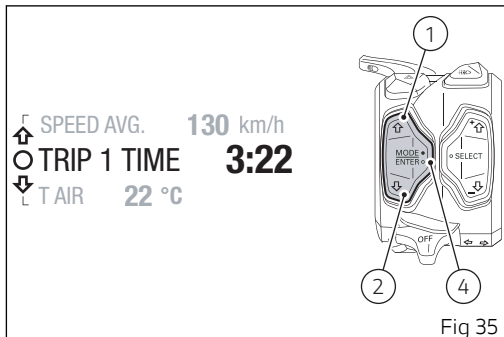

If you press button (1) or (2), the instrument panel will display TRIP 1 TIME again, without resetting the value.

While if you press button (4), value for TRIP 1 TIME will be reset and the instrument panel will display TRIP 1 TIME at "0:00".

When TRIP 1 TIME is reset, the Trip meter 1 (TRIP 1), Average speed (SPEED AVG 1) and Average Fuel Consumption (CONS. AVG 1) data are also reset.

CONS. AVG 1 counter is automatically reset also in the following cases:

- when Trip meter 1 (TRIP 1) is reset;
- when Average Fuel Consumption (CONS. AVG 1) is reset;
- due to a battery disconnection (Battery-Off);
- in case of manual change of the units of measurement of the system.

## Ambient air temperature (T-AIR)

To select this function in the Function Menu, scroll the functions available using buttons (1) and (2) to display "T AIR".

The instrument panel displays the ambient temperature followed by "T AIR" and the set unit of measurement (°C or °F).

The temperature value is displayed when ranging from -39 °C to +125 °C (or -38 °F ÷ +257 °F). For temperature values lower than -39 °C (-38 °F) or higher than +125 °C (+257 °F) a string of three steady dashes " - - - " is displayed followed by the unit of measurement.

If the instrument panel is not receiving air temperature value, a string of three steady dashes " - - - " is displayed, followed by the unit of measurement.

### Note

When the motorcycle is stopped, the engine heat could influence the displayed temperature.

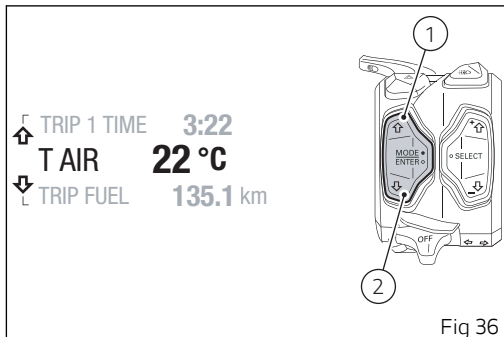

## Partial fuel reserve counter (TRIP FUEL)

To select this function in the Function Menu, scroll the functions available using buttons (1) and (2) to display "TRIP FUEL".

The fuel trip meter counts and displays the distance covered by the motorcycle on reserve (i.e. since the Low Fuel Light turns on, warning light 5, see "Instrument panel") with the set unit of measurement (km or mi).

When the Low Fuel Light turns on (warning light 5, see "Instrument panel"), the display automatically shows the TRIP FUEL function, regardless of the currently displayed function; then, it is possible to toggle through the other Function Menu functions. Trip fuel reading remains stored even after Key-Off until the motorcycle is refuelled. Count is interrupted automatically as soon as fuel is topped up to above minimum level.

The number of mi or km is displayed with the TRIP FUEL indication and unit of measurement.

When the reading exceeds the maximum value of 9999.9 km or 9999.9 mi, distance travelled is reset and the meter automatically starts counting from 0 again.

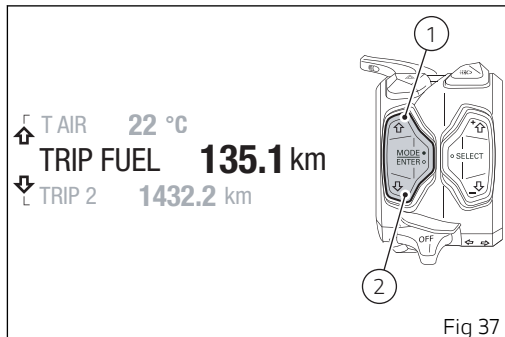

Fig 37

When the TRIP FUEL function is not active, the corresponding value will not be displayed in the Function Menu.

## Trip meter 2 (TRIP 2)

To select this function in the Function Menu, scroll the functions available using buttons (1) and (2) to display "TRIP 2".

The trip meter counts and displays the partial distance covered by the motorcycle with the set unit of measurement (km or mi). The mi or km value for TRIP 2 is displayed with the "TRIP 2" indication and unit of measurement.

When the reading exceeds the maximum value of 9999.9 mi or 9999.9 km, distance is reset and the meter automatically starts counting from 0 again.

If button (4) is pressed when trip meter is displayed, the instrument panel will activate the warning "TRIP 2 RESET ?" in place of the value and units of measurement. When this warning is active, Function Menu scrolling is not possible.

If you press button (1) or (2), the instrument panel will display TRIP 2 again, without resetting the value. While if you press button (4), value for TRIP 2 will be reset and the instrument panel will display TRIP 2 at "0.0" followed by set unit of measurement.

The TRIP 2 counter is automatically reset in case the system unit of measurement is changed manually or

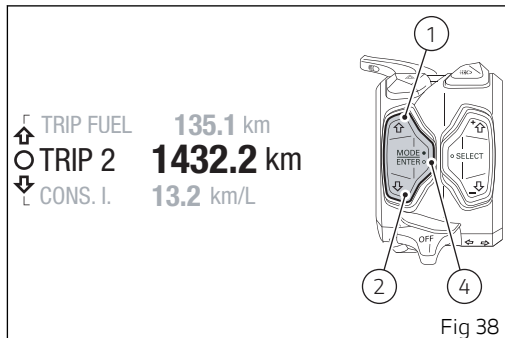

after a battery-OFF: the counter will then start back from zero, considering the new units of measurement.

## Instantaneous fuel consumption

To select this function in the Function Menu, scroll the functions available using buttons (1) and (2) to display "CONS. I."

The instrument panel calculates and shows vehicle instant fuel consumption.

The instantaneous fuel consumption is displayed with the indication "CONS. I." and the indication of the unit of measurement (km/l or l/100 km or mpg UK or mpg US).

The calculation is made considering the quantity of fuel used and the distance travelled during the last second.

Value is expressed in the set unit of measurement (km/l or l/100 km or mpg UK or mpg US).

The active calculation phase only occurs when the engine is running and the vehicle is moving (times when the vehicle is not moving when speed is equal to 0 and/or when the engine is off are not considered).

During the phase when no calculation is performed, three steady dashes " - - - " are displayed as a value of instantaneous consumption.

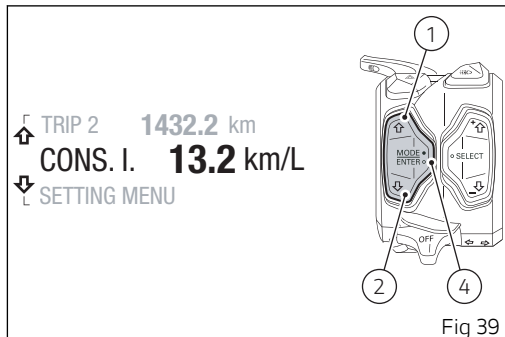

### Note

It is possible to change the units of measurement for "Consumption" (both average and instantaneous together) through the Setting MENU, using the UNITS function.

## Lap time (LAP Off / On)

This function is available for the TRACK ( display mode only.

To select this function in the Function Menu, scroll the functions available using buttons (1) and (2) to display "LAP".

This function allows enabling/disabling the Lap time (LAP Time) page recording function.

If LAP is not active, the instrument panel displays "LAP OFF". Press button (4) to switch it on.

If LAP is active, the instrument panel displays "LAP ON". Press button (4) to switch it off.

It is possible to activate or deactivate LAP also through the Setting Menu page 0 .

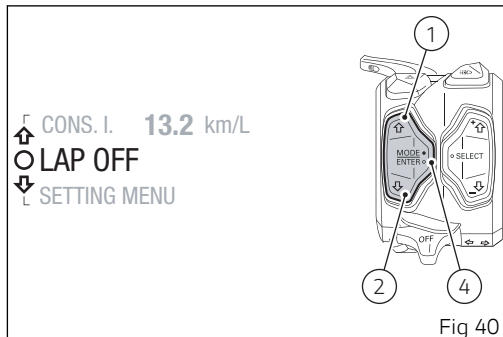

## Player management (PLAYER Off / On)

This function is available for the ROAD (display mode only).

To select this function in the Function Menu, scroll the functions available using buttons (1) and (2) to display "PLAYER".

This function allows managing (turning on and off) the Player.

The PLAYER function is only available in the Function Menu if the Bluetooth module is available and one Smartphone is connected.

If Player is not active, the instrument panel displays "PLAYER OFF". To turn it on and open the Player menu, press button (4) (please refer to "Infotainment", page for information on how to use the Player).

If Player is active, the instrument panel displays "PLAYER ON". To open the Player menu, press button (1) for 2 seconds (please refer to "Infotainment", page for information on how to use the Player).

To turn Player off, press button (4).

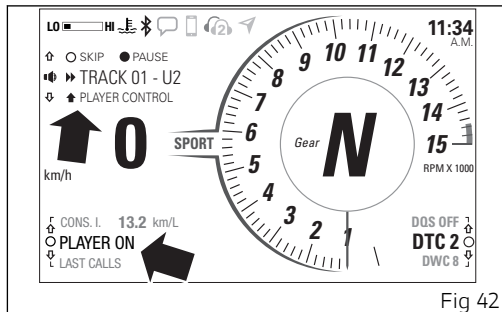
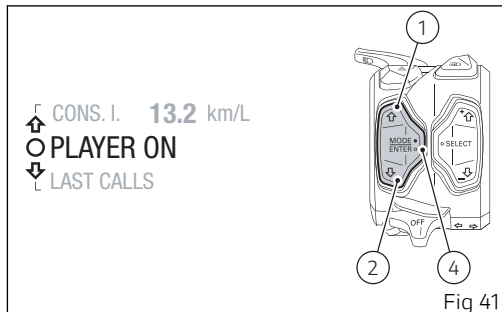

## Call management (LAST CALLS)

This function is available for the ROAD ( display mode only.

To select this function in the Function Menu, scroll the functions available using buttons (1) and (2) to display "LAST CALLS".

This function shows a list of the last calls missed, made or received.

The LAST CALLS function is only available in the Function Menu if the Bluetooth module is available and one Smartphone is connected.

Press button (4): when opening this function, a list of maximum 7 calls is displayed - these could be missed, made or received calls.

The instrument panel displays the corresponding name(s) or phone number(s). Use buttons (1) and (2) to scroll the list and press button (4) to call the displayed name or phone number.

If list includes no calls, the instrument panel displays "EMPTY" within the Function Menu.

To exit the function and go back to the previous screen, press button (2) for 2 seconds.

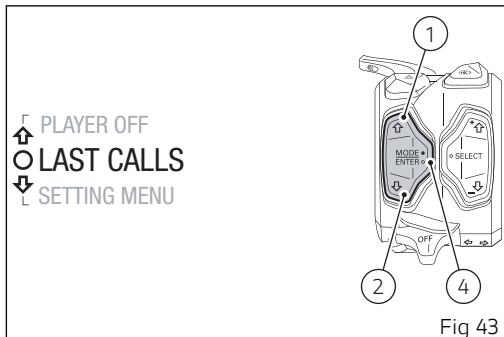

## Setting menu (SETTING MENU)

This menu allows enabling, disabling and setting some motorcycle functions.

For safety reasons, you can enter this Menu only when the actual vehicle speed is lower than or equal to 5 km/h (3 mph). If you are inside the SETTING MENU and the actual vehicle speed exceeds 5 km/h (3 mph) the instrument panel automatically exits from the SETTING MENU and displays the main screen.

To gain access to the SETTING MENU, use button (1) or (2) to select "SETTING MENU" in the left Menu (by displaying it in the "main" position, that is in the central box) and press button (4).

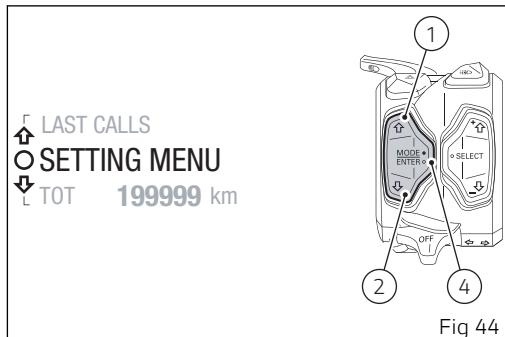

The following indications will be displayed inside the Setting Menu:

- ◀ Exit
- Riding Mode
- Pin Code
- Lap
- Backlight
- Date and Clock
- Units
- Service
- Tire Calibration
- DRL
- Bluetooth
- Turn indicators
- DDA
- Info
  - BATTERY
  - RPM
- ◀ Exit



### Important

For safety reasons, it is recommended to use this Menu with the motorcycle at a standstill.

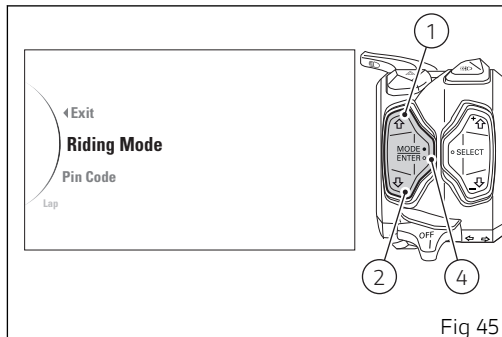

Fig 45

The functions that can be set and consulted are the following:

- Riding Modes
- Pin Code (activation and modification of PIN CODE)
- Lap (Lap time)
- Backlight (setting backlight to AUTO, DAY, NIGHT)
- Date and Clock (setting Date and Time)
- Units (setting the unit of measurement)
- Service (indication of Service thresholds)

- Tyre Calibration (Drive Ratio and Tyre Calibration)
- DRL (management of DRL lights; the DRL lights are not present in China, Canada and Japan versions)
- Bluetooth (deletion of associated devices and pairing) (function active only if the Bluetooth control unit is available; in this model it is not available, but it can be purchased)
- Turn indicators (Disabling turn indicators automatic switch off)
- DDA (displaying of DDA information) (function active only if DDA option is present)
- Info
  - BATTERY (battery voltage indication)
  - RPM (engine rpm digital indication)

To quit the SETTING MENU, keep button (4) pressed when the " ◀ Exit" indication is in "main" position.

Press buttons (1) and (2) to set the Functions listed above to the "main" position: this means that the indication of the function is highlighted with a more visible character (example **Riding Mode**).

After displaying the required function in the "main" position, press button (4) to open the corresponding menu page.

## Customising the Riding Mode

All settings of every riding mode can be customised.

Enter the SETTING MENU.

Select **Riding Mode** by pressing button (1) or (2).

Once function is displayed, press button (4).

After entering the function, the display shows the available riding modes (Race, Sport and Street) on the left side and set Riding Mode on the right side. The following indications will be displayed in this page:

- ◀ Back
- Race
- Sport
- Street
- All Default (visible only if one or more parameters of one or more Riding Modes are different from the "default" ones)
- ◀ Back

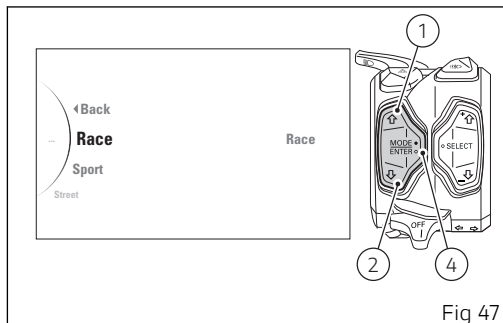
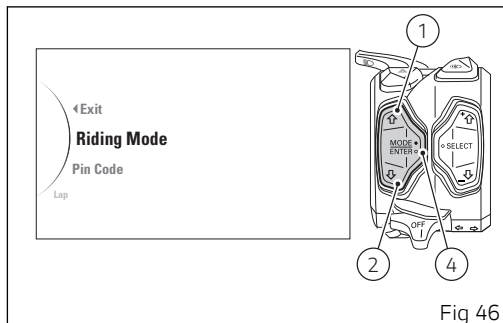

You can use buttons (1), (2) and (4) to do the following:

- use buttons (1) and (2) to highlight and select the riding mode to customise, then press button (4) to access the customisation page for the selected riding mode;
- use buttons (1) and (2) to highlight and select “◀ Back”, then press button (4) to go back to previous page;
- use buttons (1) and (2) to highlight and select “All Default”, press button (4) to reset to default values for all four Riding Modes.

The parameters linked to a riding mode that can be customised are DAVC (DTC, DWC, DSC), Engine, ABS, EBC, DQS, Info Mode, DES (Suspension) and DEFAULT (to reset to default factory values for the riding mode). The following indications will be displayed in this page:

- ◀ Back
- DAVC
- Engine
- ABS
- EBC
- DQS

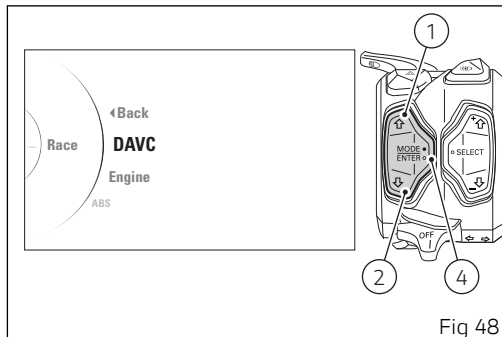

Fig 48

- Info Mode
- DES
- Default (visible only if one or more parameters are different from the "default" ones)
- ◀ Back

Every time button (1) or button (2) is pressed, the instrument panel allows scrolling all parameters of the Riding Mode selected; once parameter is highlighted, press button (4) to enter parameter customisation page where you can edit the settings of the parameter.

Any parameter change made is saved and remains in the memory also after a battery-off. The parameters set by Ducati for each individual riding mode can be reset with the "Default" function and by pressing button (4). Highlight "◀ **Back**" and press button (4) to exit the sub-menu and go back to previous page.



### **Attention**

Changes should only be made to the parameters by people who are experts in motorcycle set-up; if the parameters are changed accidentally, use the "DEFAULT" function to restore factory settings.

The DAVC function is the package of electronic controls (DTC, DWC, DSC) managing motorcycle traction during the acceleration phase: if the DTC is disabled (set to OFF), the DWC parameter can not be changed and is forced to level OFF.

## Customising the Riding Mode: DAVC

This function allows setting the levels of functions DTC DWC DSC grouped in the DAVC function associated to each riding mode.

Enter the SETTING MENU.

Select **Riding Mode** (A), by pressing button (1) or (2). Once function is displayed, press button (4).

You will access the Riding Mode menu.

Select the desired riding mode (Race, Sport, Street) (B) to be edited, by pressing button (1) or (2). Once the desired riding mode is selected, press button (4).

You will access the selected riding mode customisation menu (e.g., "Race") (C).

Press button (1) or button (2) to highlight and select "DAVC" and press button (4).

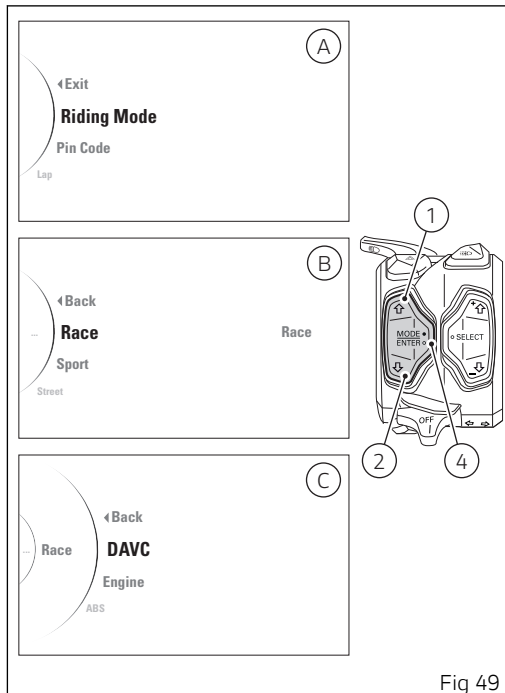

Fig 49

The DAVC function is the package of electronic controls (DTC, DWC, DSC) managing motorcycle traction during the acceleration phase.

When entering the function, it is possible to select the function to be customised (DTC, DWC, DSC). The following selectable indications will be displayed in this page:

- ◀ Back
- DTC
- DWC
- DSC
- Default (visible only if one or more parameters are different from the "default" ones)
- ◀ Back

Every time button (1) or button (2) is pressed, the instrument panel allows scrolling DTC, DWC, DSC functions; once the function is highlighted, press button (4) to enter the function to be customised. Highlight "◀ Back" and press button (4) to exit the sub-menu and go back to previous page.

For DTC function, refer to paragraph page 113.  
For DWC function, refer to paragraph page 116.  
For DSC function, refer to paragraph page 119.

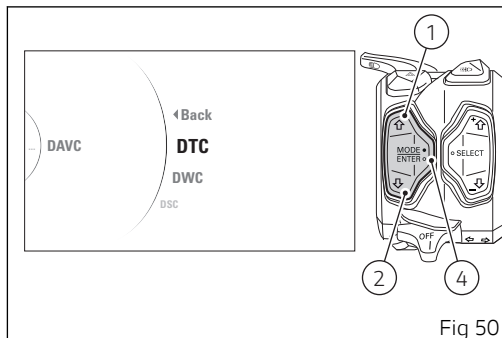

If the DTC is disabled (set to OFF), the DWC parameter can not be changed and is forced to level OFF.

For DAVC function, which includes DTC, DWC and DSC functions, it is possible to restore the parameters set by Ducati for all the functions: press button (1) or button (2) to highlight and select "Default" and press button (4).

The default parameters for DAVC function, which includes DTC, DWC and DSC functions for the selected Riding Mode, are reset.

From this moment (and until one or more parameters are customised) the "Default" indication is no longer visible.

To exit the menu and go back to previous page highlight the " ◀ Back" indication and press button (4).

## Customizing the Riding Mode: setting the DTC level

This function disables or sets DTC level for the selected riding mode.

Enter the SETTING MENU.

Select **Riding Mode** (A), by pressing button (1) or (2).  
Once function is displayed, press button (4).

You will access the Riding Mode menu.

Select the desired riding mode (Race, Sport, Street) (B) to be edited, by pressing button (1) or (2).  
Once the desired riding mode is selected, press button (4).

You will access the selected riding mode customisation menu (e.g., "Race" (C).

Press button (1) or button (2), select "**DAVC**" and press button (4).

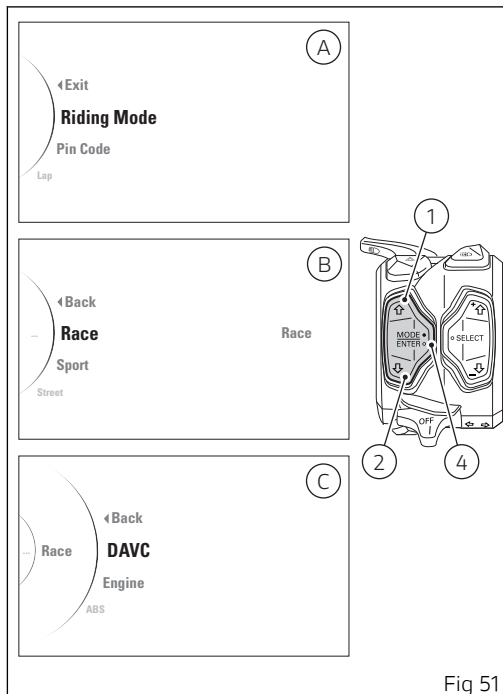

Fig 51

In DAVC function menu, press button (1) or button (2) to highlight and select "DTC" and press button (4). When you access the function, all possible customisation levels (levels from 1 to 8 and OFF status) are listed on the left and the set DTC level or status is shown on the right.

The following selectable indications will be displayed in this page:

- ◀ Back
- 8
- 7
- 6
- 5
- 4
- 3
- 2
- 1
- Off
- ◀ Back

The motorbike profile with the part where you will be acting highlighted in Light Blue will also be displayed.

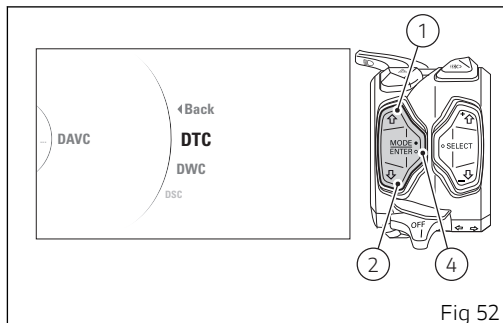

Fig 52

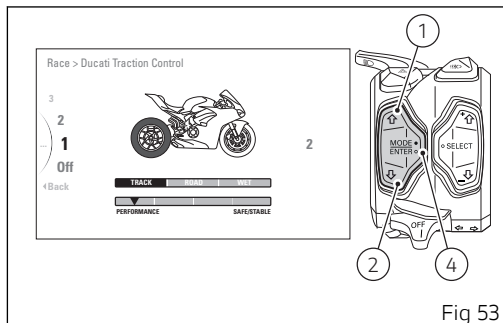

Fig 53

With buttons (1) and (2) select the new level of intervention desired. For each highlighted level, the corresponding paired value in the central table (highlighted with a black background or arrow ▼) will be displayed. If level 7 is selected, "**RAIN TIRE ONLY!**" is displayed.

Once the desired level is highlighted, press button (4) to memorise the new selection.

To exit the menu and go back to previous page highlight the " ◀ Back" indication and press button (4).

### **Note**

If the DTC is disabled (set to OFF), the DWC parameter cannot be changed and is forced to level OFF and therefore the relevant setting menu is not available.

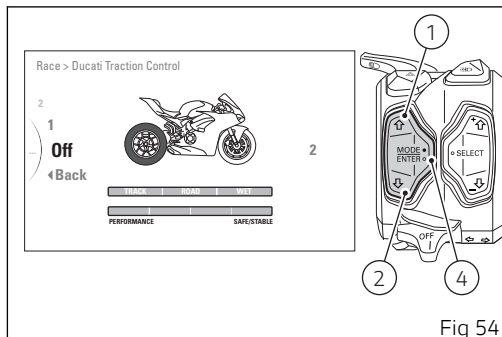

Fig 54

## Customizing the Riding Mode: setting the DWC level

This function disables or sets DWC level for the selected riding mode.

Enter the SETTING MENU.

Select **Riding Mode** (A), by pressing button (1) or (2).  
Once function is displayed, press button (4).

You will access the Riding Mode menu.

Select the desired riding mode (Race, Sport, Street) (B) to be edited, by pressing button (1) or (2).  
Once the desired riding mode is selected, press button (4).

You will access the selected riding mode customisation menu (e.g., "Race" (C)).

Press button (1) or button (2), select "**DAVC**" and press button (4).

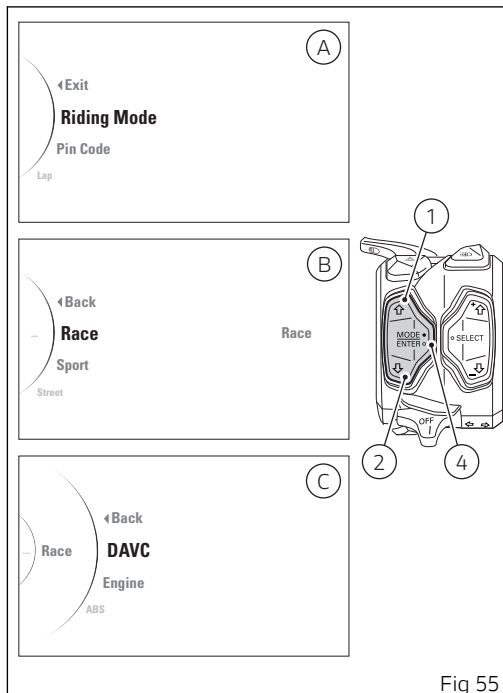

Fig 55

In DAVC function menu, press button (1) or button (2) to highlight and select “**DWC**” and press button (4). When you access the function, all possible customisation levels (levels from 1 to 8 and OFF status) are listed on the left and the set DWC level or status is shown on the right.

The following selectable indications will be displayed in this page:

- ◀ Back
- 8
- 7
- 6
- 5
- 4
- 3
- 2
- 1
- Off
- ◀ Back

The motorbike profile with the part where you will be acting highlighted in Light Blue will also be displayed.

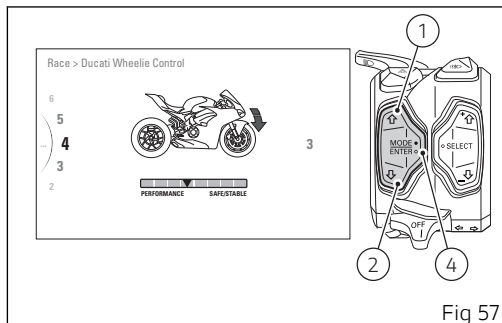
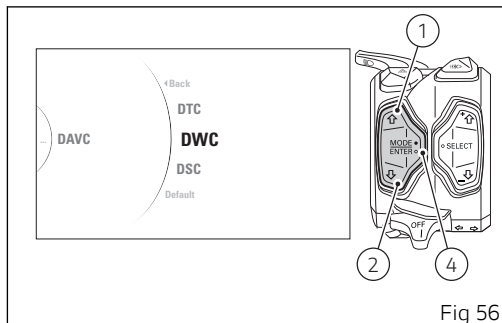

With buttons (1) and (2) select the new level of intervention desired. For each highlighted level, the corresponding paired value in the central table (highlighted with a black arrow ▼) will be displayed. Moreover, the system intervention level will be indicated with a Light Blue arrow. Once the desired level is highlighted, press button (4) to memorise the new selection. To exit the menu and go back to previous page highlight the " ◀ Back" indication and press button (4).

### Note

If the DTC is disabled (set to OFF), the DWC parameter cannot be changed and is forced to level OFF and therefore the relevant setting menu is not available.

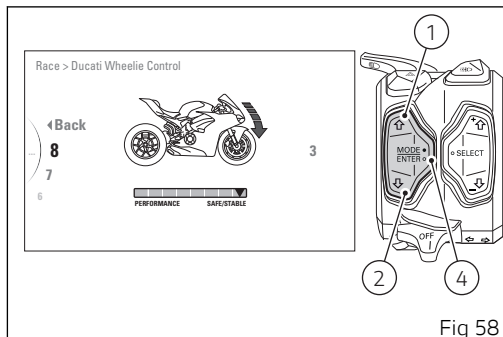

Fig 58

## Customizing the Riding Mode: setting the DSC level

This function disables or sets DSC level for the selected riding mode.

Enter the **SETTING MENU**.

Select **Riding Mode** (A), by pressing button (1) or (2).  
Once function is displayed, press button (4).

You will access the Riding Mode menu.

Select the desired riding mode (Race, Sport, Street) (B) to be edited, by pressing button (1) or (2).  
Once the desired riding mode is selected, press button (4).

You will access the selected riding mode customisation menu (e.g., "Race" (C)).

Press button (1) or button (2), select "**DAVC**" and press button (4).

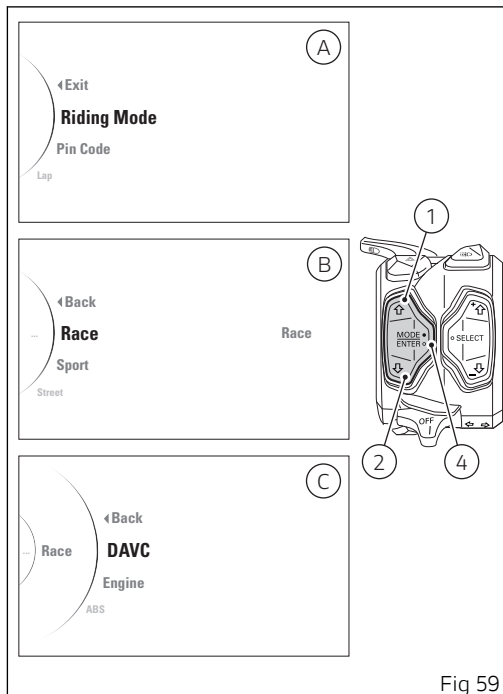

Fig 59

In DAVC function menu, press button (1) or button (2) to highlight and select "DSC" and press button (4). When you access the function, all possible customisation levels (levels 1 and 2 and OFF status) are listed on the left and the set DSC level or status is shown on the right.

The following selectable indications will be displayed in this page:

- ◀ Back
- 2
- 1
- Off
- ◀ Back

The motorbike profile with the part where you will be acting will also be displayed.

With buttons (1) and (2) select the new level of intervention desired. For each highlighted level, the corresponding paired value in the central table (highlighted with a black background or arrow ▼) will be displayed.

Once the desired level is highlighted, press button (4) to memorise the new selection.

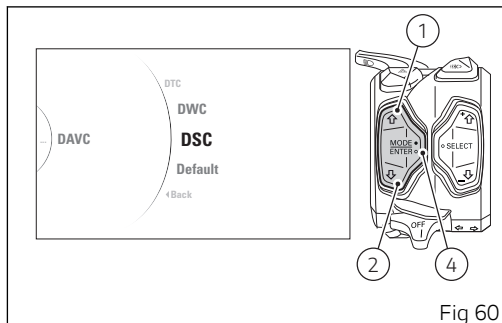

Fig 60

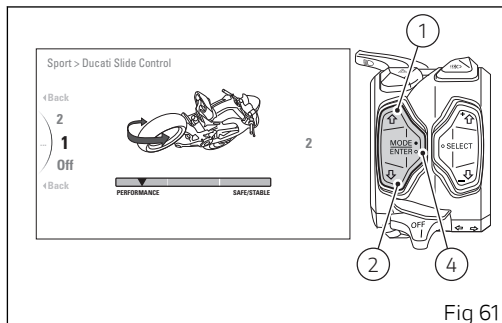

Fig 61

To exit the menu and go back to previous page highlight the " ◀ **Back**" indication and press button (4).

## Customizing the Riding Mode: engine adjustment

This function customises engine power associated with each riding mode.

Enter the SETTING MENU.

Select **Riding Mode** (A), by pressing button (1) or (2). Once function is displayed, press button (4).

You will access the Riding Mode menu.

Select the desired riding mode (Race, Sport, Street) (B) to be edited, by pressing button (1) or (2). Once the desired riding mode is selected, press button (4).

You will access the selected riding mode customisation menu (e.g., "Race") (C).

Press button (1) or button (2) to highlight and select "Engine" and press button (4).

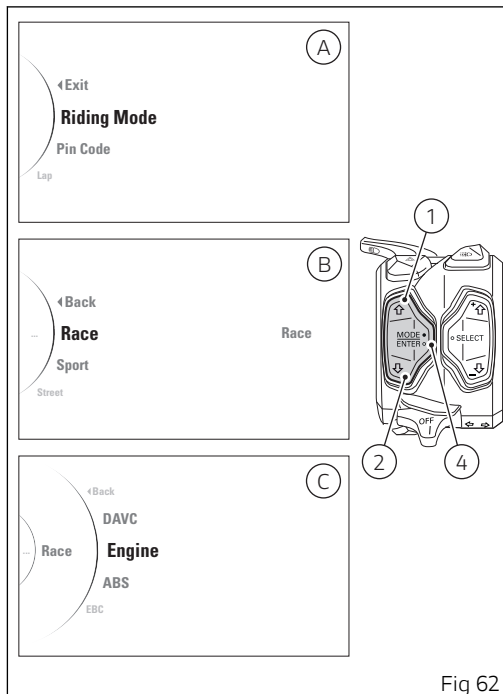

Fig 62

When entering the function, settings available for customisation are indicated on the left: High, Medium, Low whereas the set value is displayed on the right.

The following selectable indications will be displayed in this page:

- ◀ Back
- High
- Medium
- Low
- ◀ Back

The motorbike profile with the part where you will be acting highlighted in Light Blue will also be displayed.

With buttons (1) and (2) select the new desired engine power.

For each highlighted level, the corresponding paired value in the central table (highlighted with a black background) will be displayed.

Once the desired level is highlighted, press button (4) to confirm the selection.

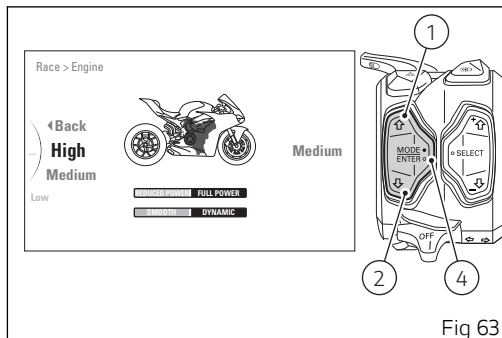

To exit the menu and go back to previous page highlight the "◀ Back" indication and press button (4).

## Customizing the Riding Mode: ABS adjustment

This function disables or sets ABS level for the selected riding mode.

Enter the SETTING MENU.

Select **Riding Mode** (A), by pressing button (1) or (2). Once function is displayed, press button (4).

You will access the Riding Mode menu.

Select the desired riding mode (Race, Sport, Street) (B) to be edited, by pressing button (1) or (2). Once the desired riding mode is selected, press button (4).

You will access the selected riding mode customisation menu (e.g., "Race") (C).

Press button (1) or button (2) to highlight and select "ABS" and press button (4).

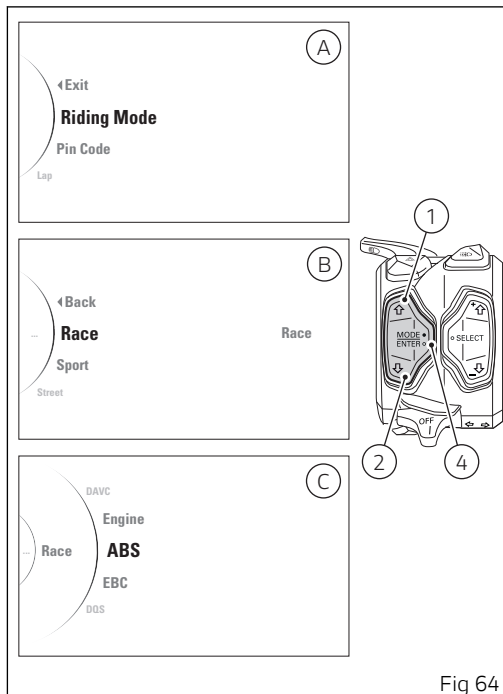

Fig 64

When you access the function, all possible customisation levels (levels from 1 to 3) are listed on the left and the set ABS level or status is shown on the right.

The following selectable indications will be displayed in this page:

- ◀ Back
- 3
- 2
- 1
- ◀ Back

The motorbike profile with the part where you will be acting highlighted in Light Blue will also be displayed.

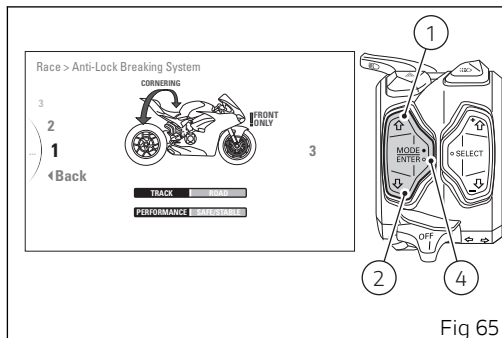
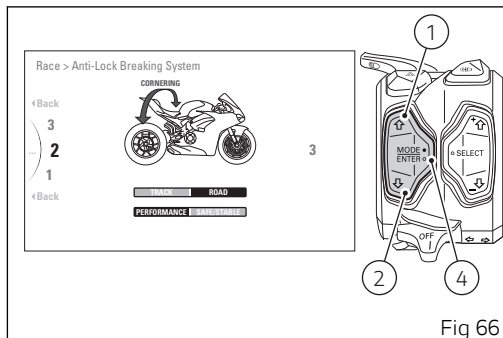

Fig 65

With buttons (1) and (2) select the new level of intervention desired. For each highlighted level, the corresponding paired value in the central table (highlighted with a black background) will be displayed. Moreover, the braking system intervention level will be indicated in Light Blue: **"FRONT ONLY!"** (Fig 65) for front brake active only, **"CORNERING"** (Fig 66) for Cornering function active.

Once the desired level is highlighted, press button (4) to memorise the new selection.

To exit the menu and go back to previous page highlight the " ◀ Back" indication and press button (4).



## Customizing the Riding Mode: setting the EBC level

This function disables or sets the rear wheel antilocking system (EBC) level for every single riding mode.

Enter the SETTING MENU.

Select **Riding Mode** (A), by pressing button (1) or (2).

Once function is displayed, press button (4).

You will access the Riding Mode menu.

Select the desired riding mode (Race, Sport, Street) (B) to be edited, by pressing button (1) or (2).

Once the desired riding mode is selected, press button (4).

You will access the selected riding mode customisation menu (e.g., "Race") (C).

Press button (1) or button (2) to highlight and select

**"EBC"** and press button (4).

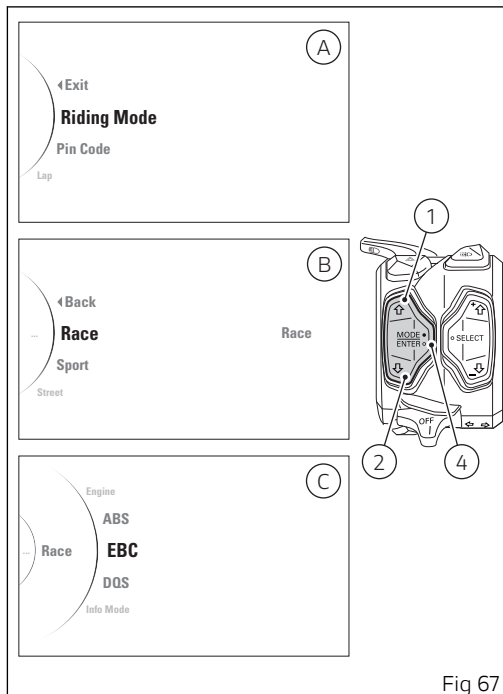

Fig 67

When you access the function, all possible customisation levels (levels from 1 to 3 and OFF status) are listed on the left and the set EBC level or status is shown on the right.

The following selectable indications will be displayed in this page:

- ◀ Back
- 3
- 2
- 1
- Off
- ◀ Back

The motorbike profile with the part where you will be acting highlighted in Light Blue will also be displayed.

With buttons (1) and (2) select the new level of intervention desired. For each highlighted level, the corresponding paired value in the central table (highlighted with a black arrow ▼) will be displayed. Once the desired level is highlighted, press button (4) to memorise the new selection.

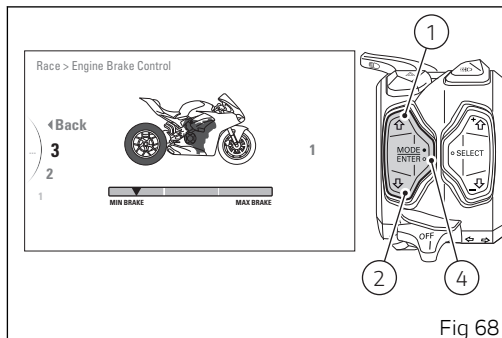

To exit the menu and go back to previous page highlight the "◀ Back" indication and press button (4).

## Customizing the Riding Mode: DSQ enabling/disabling

This function disables or enables the DQS for the selected riding mode.

Enter the SETTING MENU.

Select **Riding Mode** (A), by pressing button (1) or (2). Once function is displayed, press button (4).

You will access the Riding Mode menu.

Select the desired riding mode (Race, Sport, Street) (B) to be edited, by pressing button (1) or (2). Once the desired riding mode is selected, press button (4).

You will access the selected riding mode customisation menu (e.g., "Race") (C).

Press button (1) or button (2) to highlight and select "DQS" and press button (4).

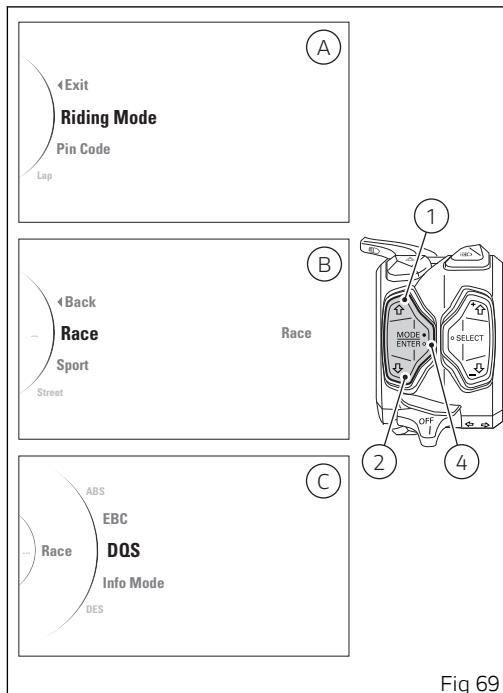

Fig 69

When you access the function, all possible customisation levels (OFF, UP/DOWN) are listed on the right and the currently set DQS level or status is shown on the left.

The following selectable indications will be displayed in this page:

- ◀ Back
- Up/Down
- Off
- ◀ Back

The motorbike profile with the part where you will be acting highlighted in Light Blue will also be displayed.

With buttons (1) and (2) select the new level of intervention desired. For each highlighted level, the system intervention level (highlighted with two black arrows) will be displayed.

Once the desired level is highlighted, press button (4) to memorise the new selection.

To exit the menu and go back to previous page highlight the "◀ Back" indication and press button (4).

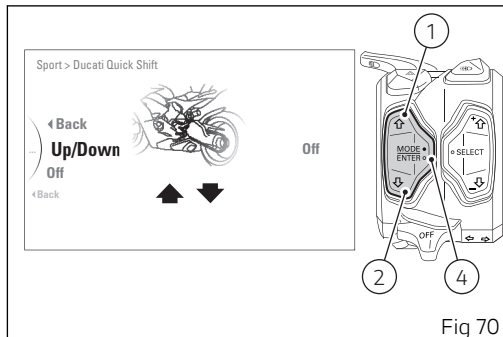

## Customizing the Riding Mode: display mode setting (Info Mode)

This function allows rider to select the main screen displaying mode associated with every riding mode.

To select the desired mode, open the SETTING MENU.

Select **Riding Mode** (A), by pressing button (1) or (2). Once function is displayed, press button (4). You will access the Riding Mode menu.

Select the desired riding mode (Race, Sport, Street) (B) to be edited, by pressing button (1) or (2). Once the desired riding mode is selected, press button (4).

You will access the selected riding mode customisation menu (e.g., "Race") (C). Press button (1) or button (2) to highlight and select "Info Mode" and press button (4).

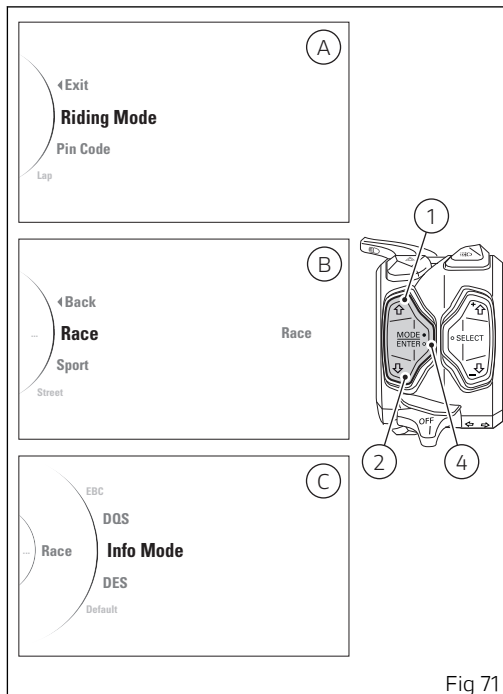

After entering the function, the display shows the available Info Modes ("Track" and "Road") on the left side and set Info Mode on the right side. Within this page, the instrument panel displays the following indications:

- ◀ Back
- Track
- Road
- Default
- ◀ Back

The "Default" indication is visible only if one or more parameters have been modified.

With buttons (1) and (2) select the new desired Info Mode. Once the desired Info Mode is highlighted, press confirm button (4) to memorize the new selection.

To exit the menu and go back to previous page highlight the "◀ Back" indication and press button (4).

There are two available display modes: TRACK and ROAD. Every mode is associated to a Riding Mode and in "Default" mode, when the Riding Mode changes, also the display mode changes.

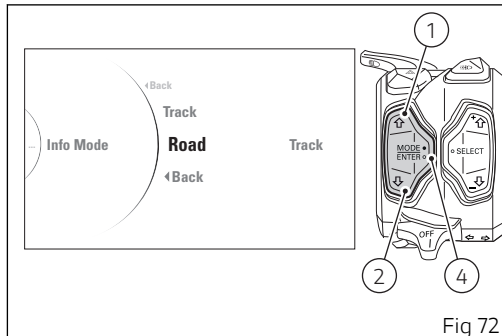

Fig 72

Ducati associated by default the layouts to the Riding modes as follows:

- TRACK layout for the RACE Riding Mode;
- ROAD layout for the SPORT Riding Mode and for the STREET Riding Mode.

## Customizing the Riding Mode: DES adjustment

This function allows selecting the control type of the electronic suspensions of each riding mode.

Enter the SETTING MENU.

Select **Riding Mode** (A), by pressing button (1) or (2).  
Once function is displayed, press button (4).

You will access the Riding Mode menu.

Select the desired riding mode (Race, Sport, Street) (B) to be edited, by pressing button (1) or (2).  
Once the desired riding mode is selected, press button (4).

You will access the selected riding mode customisation menu (e.g., "Race") (C).

Press button (1) or button (2) to highlight and select "DES" and press button (4).

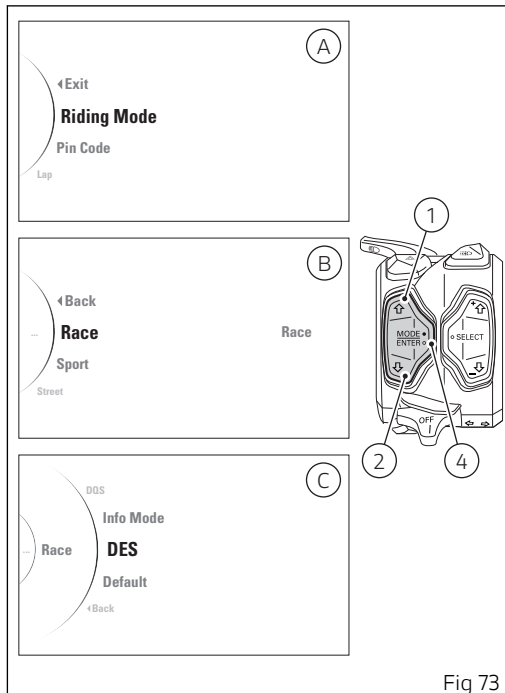

Fig 73

When you access the function, the controls that can be set / customised for suspension (FIXED, DYNAMIC) are listed on the left and the currently set level is shown on the right.

The following selectable indications will be displayed in this page:

- ◀ Back
- Fixed Suspension
- Dynamic Suspension
- ◀ Back

To exit the menu and go back to previous page highlight the "◀ Back" indication and press button (4).

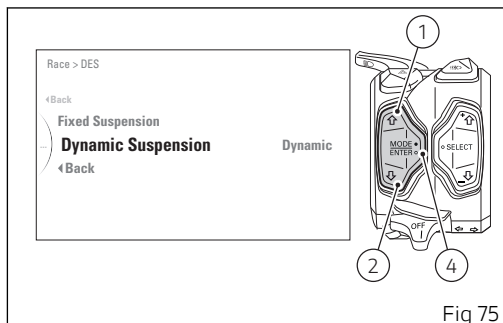
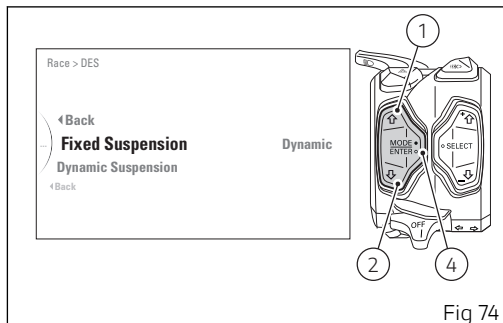

If the level set is FIXED (therefore “Fixed” is displayed on the right):

- it is possible to set DYNAMIC management by selecting “Dynamic Suspension” indication (Fig 75) with buttons (1) and (2) and pressing button (4); now select “Default Dynamic Suspension” indication (Fig 77) with buttons (1) and (2) and then press button (4);
- it is possible to customise FIXED management by selecting “Fixed Suspension” indication (Fig 74) with buttons (1) and (2) and pressing button (4) to enter the sub-menu; now select “Custom Fixed Suspension” indication (Fig 76) with buttons (1) and (2) and press button (4) to enter the customisation menu (see paragraph “Management with fixed click-settings (FIXED)”).

If the level set is DYNAMIC (therefore “Dynamic” is displayed on the right):

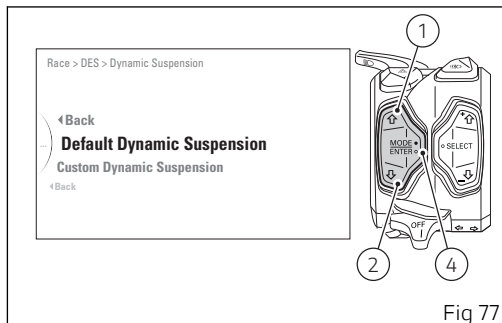
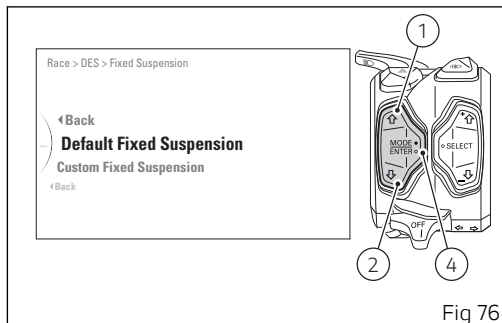

- it is possible to customise DYNAMIC management by selecting "Dynamic Suspension" indication (Fig 75) with buttons (1) and (2) and pressing button (4) to enter the sub-menu; now select "Custom Dynamic Suspension" indication (Fig 77) with buttons (1) and (2) and press button (4) to enter the customisation menu (see paragraph "Dynamic management (DYNAMIC)");
- it is possible to set FIXED management by selecting "Fixed Suspension" (Fig 74) with buttons (1) and (2) and pressing button (4). select "Default Fixed Suspension" (Fig 76) with buttons (1) and (2) and then press button (4).

## Management with fixed click-settings (FIXED)

The FIXED mode allows selecting the compression and rebound setting of the fixed click electronic suspension.

To enter the customisation page, use button (1) or (2) to select "**Custom Fixed Suspension**", when the set level is Fixed. Once selected, press button (4) to enter the FIXED management menu.

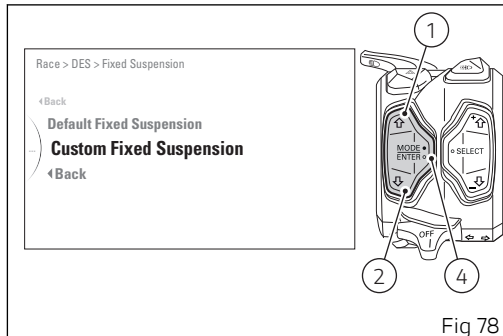

Fig 78

When entering the FIXED management menu, the following selectable options are displayed:

- ◀ Back
- Front Compression
- Front Rebound
- Rear Compression
- Rear Rebound
- Steering Damper
- ◀ Back

"Front Compression" allows accessing the customisation menu of "Front Compression" front fork compression value.

"Front Rebound" allows accessing the customisation menu of "Front Rebound" front fork rebound value.

"Rear Compression" allows accessing the customisation menu of "Rear Compression" rear shock absorber compression value.

"Rear Rebound" allows accessing the customisation menu of "Rear Rebound" rear shock absorber rebound value.

"Steering Damper" allows accessing the customisation menu of "Steering Damper" adjustment.

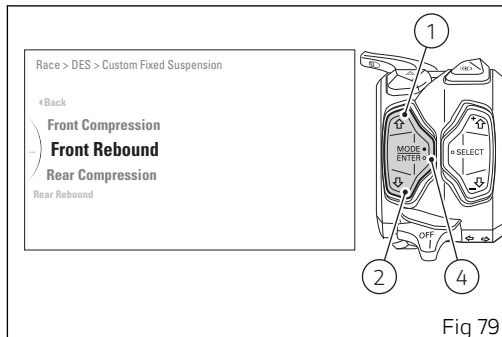

Use buttons (1) and (2) to select the parameter you wish to customise, then press button (4) to access the relevant menu.

To exit the menu and go back to previous page highlight the "◀ Back" indication and press button (4).

By selecting one of the five menus (Front Compression, Front Rebound, Rear Compression, Rear Rebound, Steering Damper), when accessing the function a list of all the possible customisation levels is available on the left, and the current set level on the right; customisation levels that can be selected are:

- number of clicks from 1 to 32 for "Front Compression", "Front Rebound", "Rear Compression", "Rear Rebound" menus;
- number of clicks from 1 to 19 for "Steering Damper" menu.

The motorbike profile with the part where you will be acting highlighted in Light Blue will also be displayed.

With button (1) or (2) select the new level of intervention desired. For each highlighted level, the corresponding paired value in the central table (highlighted with a black arrow ▼) will be displayed. Once the desired level is highlighted, press button (4) to memorise the new selection.

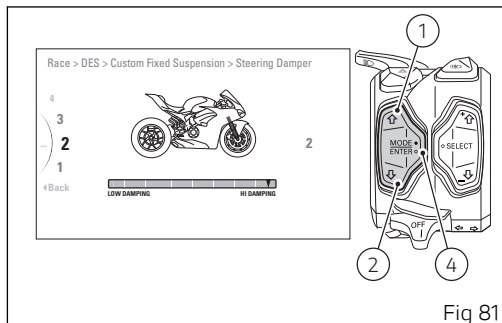
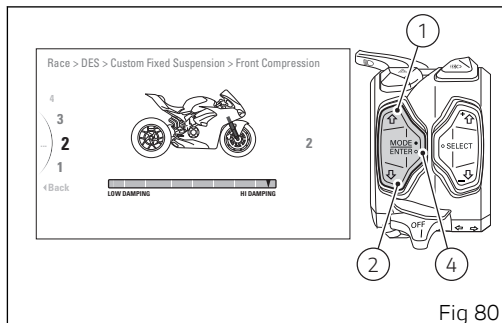

To exit the menu and go back to previous page highlight the " ◀ **Back**" indication and press button (4).

## Dynamic management (DYNAMIC)

The DYNAMIC mode allows setting the strength of intervention by the SmartEC Ohlins control unit of the electronic suspension system under the various conditions.

To enter the customisation page, use button (1) or (2) to select "**Custom Dynamic Suspension**", when the set level is Dynamic. Once selected, press button (4) to enter the DYNAMIC management menu.

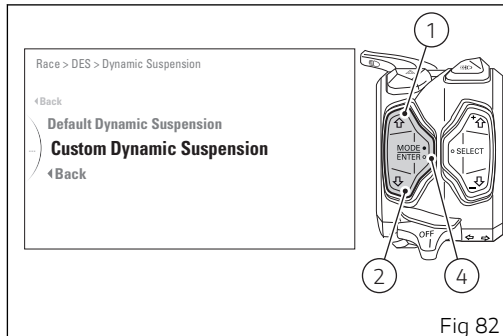

When entering the DYNAMIC management menu, the following selectable options are displayed:

- ◀ Back
- Brake Support
- Front Fork
- Shock Absorber
- Steering Damping
- Acceleration (\*)
- Mid Corner (\*)
- ◀ Back

(\*) the parameters can be displayed and thus customised in "Race" Riding Mode.

Use buttons (1) and (2) to select the parameter you wish to customise, then press button (4) to access the relevant menu.

To exit the menu and go back to previous page highlight the "◀ Back" indication and press button (4).

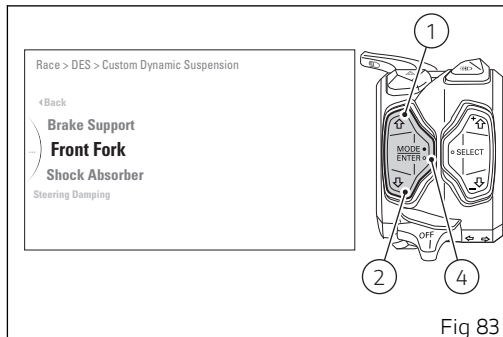

By changing the level of each parameter it is possible to increase or decrease the effects of the automatic dynamic adjustment of the system on the suspensions based on the vehicle dynamic conditions.

Riding Mode	Type of configuration	Standard DES settings	Use target	
<b>Race</b>	TRACK	Brake Support	+2	Maximise the performance on the track with Pirelli Supercorsa SC1 tyres
		Front Fork	0	
		Shock Absorber	+2	
		Steering Damping	0	
		Acceleration	+2	
		Mid Corner	0	
<b>Sport</b>	ROAD	Brake Support	0	Conceived for a sport riding style on the track and on the road with Pirelli Supercorsa SP tyres
		Front Fork	0	
		Shock Absorber	0	
		Steering Damping	0	
<b>Street</b>	ROAD	Brake Support	0	Maximise the comfort of use on the road (bumpy roads as well) with Pirelli Supercorsa SP tyres
		Front Fork	0	
		Shock Absorber	0	
		Steering Damping	0	

## Brake Support parameter

By adjusting the brake support parameter it is possible to increase (PERFORMANCE) or decrease (COMFORT) the resistance to pitching when braking. By increasing the level, the fork will dampen more slowly and in a more controlled way. By decreasing the level, the damping speed increases.

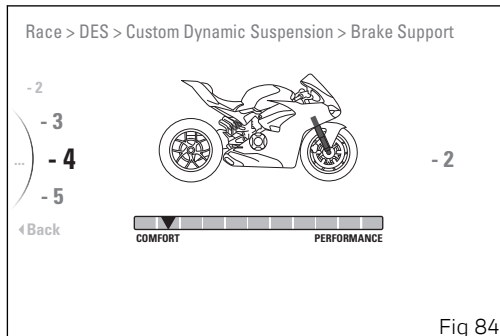

## Front Fork and Shock Absorber parameter

By adjusting the front fork and shock absorber parameters it is possible to increase (+) or decrease (-) the total damping of each component.

In the Race Riding Mode, modifying both parameters by the same value can be useful to adjust the total damping based on the rider preferences, different grip levels and track features. Modifying the parameters separately allows changing the front and rear balancing separately.

In the Sport and Street Riding Modes, set both the targets towards COMFORT to improve the damping of the road bumps and impacts. Set both targets more towards STABILITY to increase the damping of the frame wobbling. Set the front and rear parameters separately to adjust the front fork and the rear shock absorber individually and change the front and rear balancing.

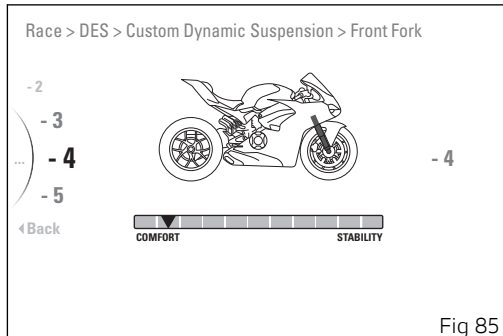

## Steering Damping parameter

By adjusting this parameter it is possible to increase or decrease the steering total damping level. Set the parameter towards HANDLING to reduce the steering damping and for a more agile riding style. Set the parameter towards STABILITY to have more resistance to oscillations.

## Acceleration parameter (available only in the "Race" Riding Mode)

By setting the acceleration parameter it is possible to express the rider preference between grip and stability during harsh accelerations. Set the parameter more towards GRIP to optimise the system so as to obtain more grip on the rear wheel and the best contact with the ground. Set the parameter towards STABILITY to reduce the frame wobbling.

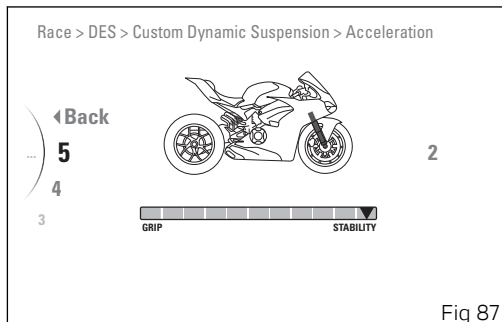
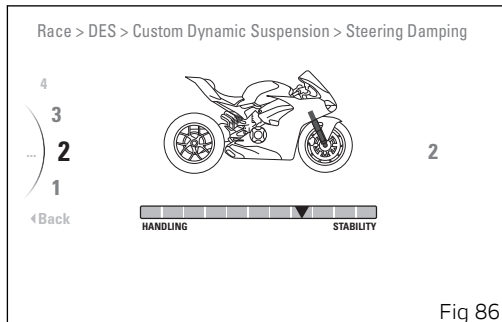

Mid Corner parameter (available only in the "Race" Riding Mode)

By setting the parameter of the curve centre it is possible to express the rider preference between grip and stability in bends. Set the parameter more towards GRIP to optimise the system so as to obtain the best contact with the ground. Set the parameter towards STABILITY to reduce the frame wobbling.

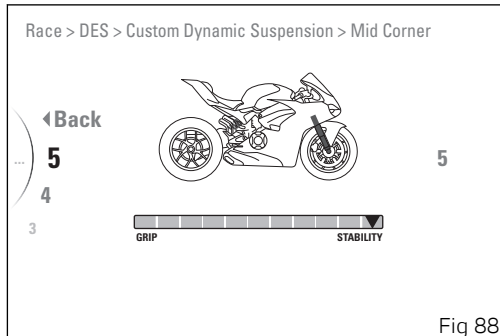

By selecting one of the six menus (Brake Support, Front Fork, Shock Absorber, Steering Damping, Acceleration, Mid Corner) when you access the function, all possible customisation levels (from +5 to -5) are listed on the left and the currently set level is shown on the right.

The motorbike profile with the part where you will be acting highlighted in Light Blue will also be displayed.

With button (1) or (2) select the new level of intervention desired. For each highlighted level, the corresponding paired value in the central table (highlighted with a black arrow ▼) will be displayed. Once the desired level is highlighted, press button (4) to memorise the new selection.

To exit the menu and go back to previous page highlight the " ◀ Back" indication and press button (4).

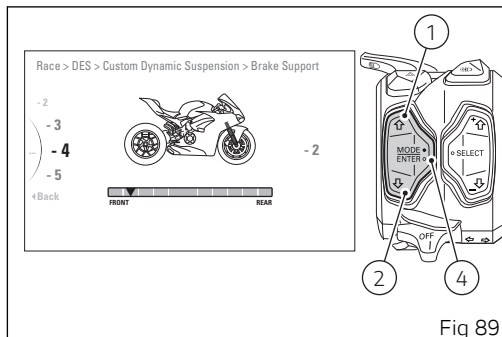

Fig 89

## Customizing the Riding Mode: restoring default settings

This function allows restoring the default values set by Ducati for the parameters associated to a specific riding mode.

Enter the **SETTING MENU**.

Select **Riding Mode** (A), by pressing button (1) or (2).

Once function is displayed, press button (4).

You will access the Riding Mode menu.

Select the desired riding mode (Race, Sport, Street) (B) to be edited, by pressing button (1) or (2). Once the desired riding mode is selected, press button (4).

You will access the selected riding mode customisation menu (e.g., "Race") (C).

Press button (1) or button (2) to highlight and select "**Default**" and press button (4).

The default parameters for the selected Riding Mode are reset.

From this moment (and until one or more parameters are customised) the "Default" indication is no longer visible.

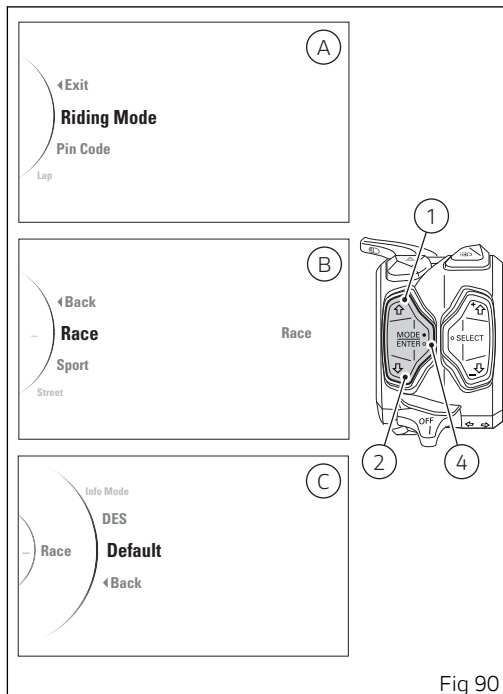

Fig 90

To exit the menu and go back to previous page highlight the " ◀ Back" indication and press button (4).

## Customising Riding Mode: restore default settings (All Default)

This function allows restoring the default values set by Ducati for parameters (DAVC (DTC, DWC, DSC), Engine, ABS, EBC, DQS, Info Mode, DES (Suspension)) and all riding modes: the function is only visible if at least one of the parameters of one riding mode is not the "default" one.

Enter the SETTING MENU.

Select **Riding Mode** by pressing button (1) or (2).

Once function is displayed, press button (4).

Use buttons (1) and (2) to highlight and select "**All Default**", press button (4) to reset to default values for all three Riding Modes.

From this moment (and until one or more parameters are customised) the "All Default" indication is no longer visible.

To exit the menu and go back to previous page highlight the "◀ Back" indication and press button (4).

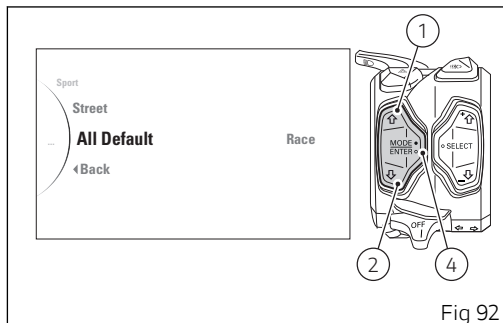
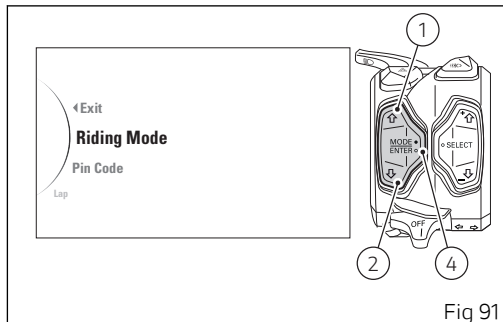

## Pin Code

This function allows the user to activate or modify the PIN CODE.

The PIN CODE is initially not present in the motorcycle, it must be activated by the user by entering his/her 4-digit PIN in the instrument panel, otherwise the motorcycle cannot be started temporarily in the case of a malfunction.

To activate and/or modify the PIN CODE you must enter the SETTING MENU.

Select **Pin Code** option, by pressing button (1) or (2). Once function is highlighted, press button (4).

To activate this function, refer to "Activating the PIN CODE" procedure below.

To change the PIN refer to "Changing the PIN CODE" procedure page 157.

In order to temporarily start the motorcycle in case of malfunction, please refer to the procedure called "Restoring motorcycle operation via the PIN CODE" page 247.

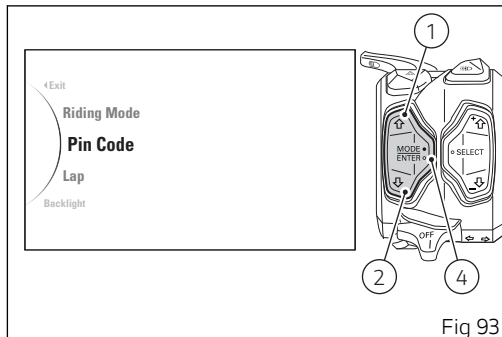

Fig 93



### Attention

The motorcycle owner must activate (store) the PIN code; if there is already a stored PIN, contact an Authorised Ducati Dealer to have the function "reset". To perform this procedure, the Authorised Ducati Dealer may ask you to demonstrate that you are the owner of the motorcycle.

## Activating the PIN CODE

To activate the PIN CODE function and enter your own PIN CODE you must open the SETTING MENU. Select **Pin Code** option, by pressing button (1) or (2). Once function is highlighted, press button (4).

As you enter this function, the instrument panel displays the following indications:

- ◀ Back
- New Pin

Use buttons (1) and (2) to select "**New Pin**" and press button (4) to enter the Pin Code entering function. To exit the menu and go back to previous page highlight the "◀ **Back**" indication and press button (4).

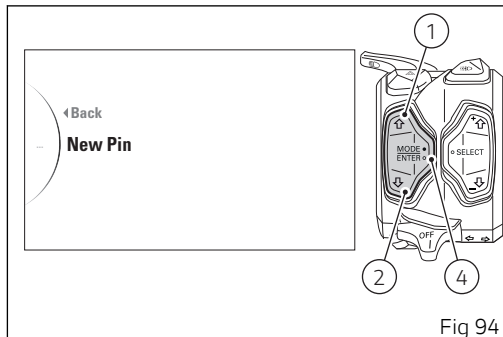

After accessing the Pin Code entering function (New Pin), the instrument panel displays "New Pin" with spaces allowing to enter the four digits of the new Pin code to be entered: "0" and "---". The two arrows on the digit give the possibility to set it.

Entering the code:

- 1) Each time you press the button (1) the displayed number increases by one (+ 1) up to "9" and then starts back from "0";
- 2) Each time you press the button (2) the displayed number decreases by one (- 1) up to "1" and then starts back from "0";
- 3) Press button (4) to confirm the number and move on to the following digit.
- 4) Repeat the operations under steps 1) - 3) until you confirm all the 4 digits of the PIN CODE.

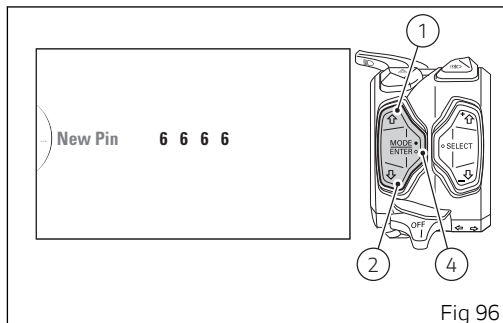
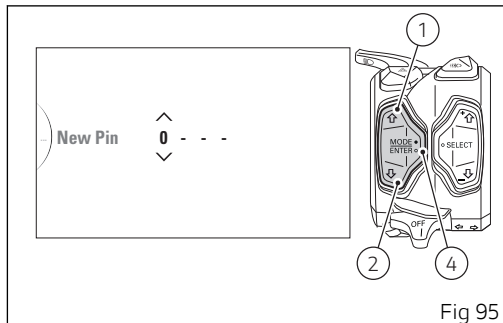

Once the "fourth" digit has been entered, when pressing button (4) the instrument panel activates the following indications:

- ◀ Back
- Memory (orange)

To exit the menu and go back to previous page highlight the "◀ Back" indication and press button (4). To memorise the entered code, highlight the "Memory" indication (orange) and press button (4). Then, the instrument panel will activate the "Memorised" indication (green) for 2 seconds.

At the end of the 2 seconds, the instrument panel goes back to the previous screen with the indication "**Modify Pin**" (instead of "New Pin") (ref. page 157): in fact, after memorising the first PIN CODE, the page of the menu where to enter the "New Pin" is no longer available and is replaced by the page to modify the PIN CODE.

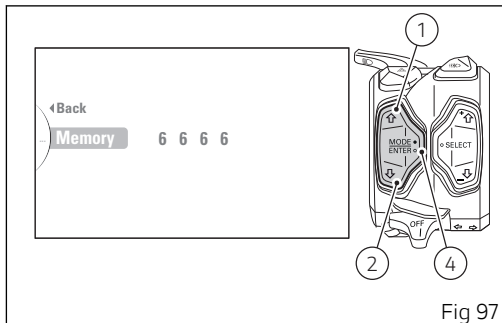

Fig 97



Fig 98



## Note

The page for entering the PIN CODE is active and available again only in case the Pin Code function is reset (but this is only possible through the DUCATI diagnosis instrument).

To exit the menu and go back to previous page highlight the " ◀ **Back**" indication and press button (4).

## Changing the Pin Code

To customise the existing PIN CODE and activate the new one, enter the SETTING MENU, use buttons (1) and (2) to select "**Pin Code**" and press button (4).



**Note** To change the PIN CODE, you must know the already stored PIN.

As you enter this function, the instrument panel displays the following indications:

- ◀ Back
- Modify Pin

Use buttons (1) and (2) to select "**Modify Pin**" and press button (4) to enter the Pin Code change function.

To exit the menu and go back to previous page highlight the "◀ **Back**" indication and press button (4).

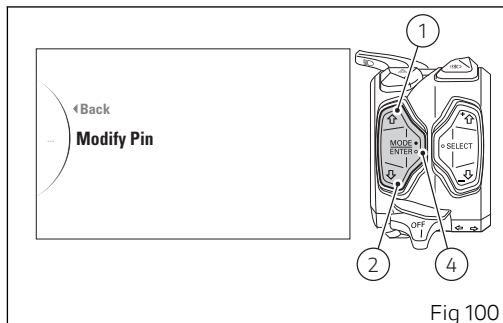
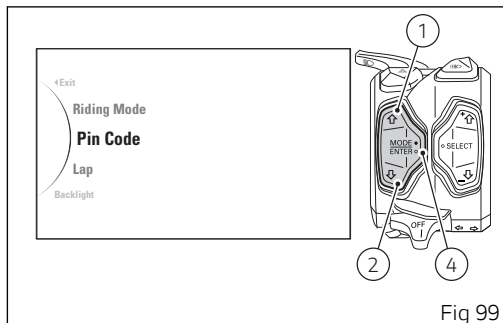

After accessing the Pin Code change function (Modify Pin), the instrument panel displays "Old Pin" with spaces allowing to enter the four digits of the set Pin code: "0" and "- - -". The two arrows on the digit give the possibility to set it.

Entering the code:

- 1) Each time you press the button (1) the displayed number increases by one (+ 1) up to "9" and then starts back from "0";
- 2) Each time you press the button (2) the displayed number decreases by one (- 1) up to "1" and then starts back from "0";
- 3) Press button (4) to confirm the number and move on to the following digit.
- 4) Repeat the operations under steps 1) - 3) until you confirm all the 4 digits of the PIN CODE.

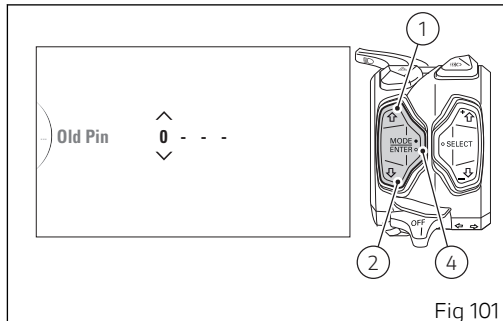

Fig 101

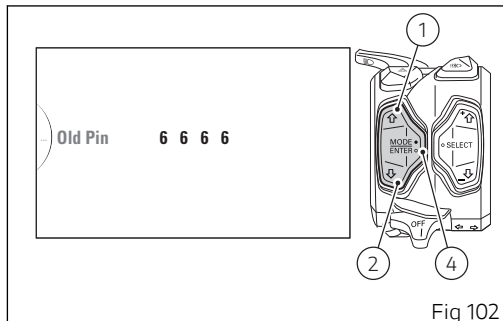

Fig 102

When you press button (4) to confirm the fourth and last digit, the instrument panel responds as follows:

- if the PIN is not correct, the instrument panel displays "WRONG" highlighted in red for 2 seconds and then highlights the menu with the indication "Modify Pin" and the spaces to enter the digits, to allow you to try again;
- if the PIN is correct, the instrument panel displays "CORRECT" for 2 seconds in green and then passes to the menu with the "New Pin" indication and the spaces to enter the digits in order to allow you to enter the new PIN CODE.

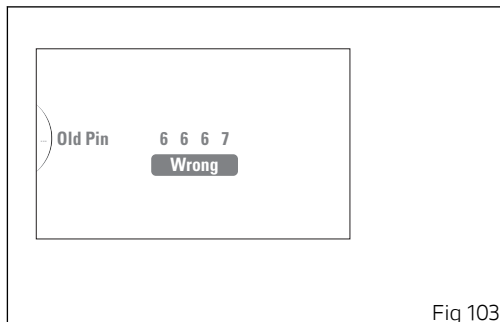

Fig 103

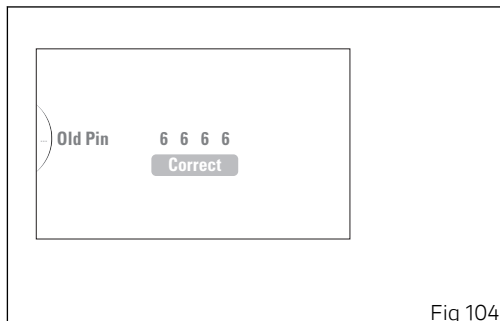

Fig 104

If the PIN is correct, the instrument panel displays the following indications:

- ◀ Back
- New Pin

Use buttons (1) and (2) to select "**New Pin**" and press button (4) to enter the Pin Code entering function. To exit the menu and go back to previous page highlight the "◀ **Back**" indication and press button (4).

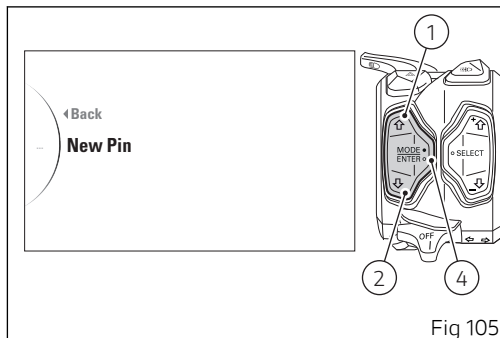
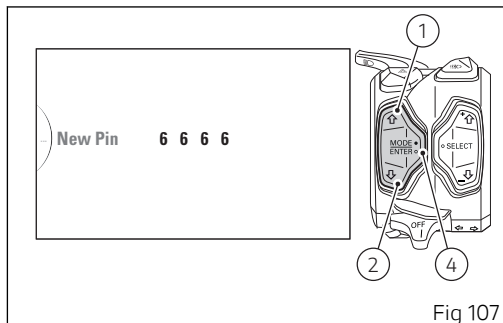
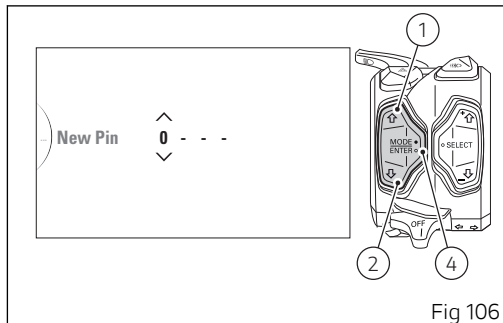

Fig 105

After accessing the Pin Code entering function (New Pin), the instrument panel displays "New Pin" with spaces allowing to enter the four digits of the new Pin code to be entered: "0" and "---". The two arrows on the digit give the possibility to set it.

Entering the code:

- 1) Each time you press the button (1) the displayed number increases by one (+ 1) up to "9" and then starts back from "0";
- 2) Each time you press the button (2) the displayed number decreases by one (- 1) up to "1" and then starts back from "0";
- 3) Press button (4) to confirm the number and move on to the following digit.
- 4) Repeat the operations under steps 1) - 3) until you confirm all the 4 digits of the PIN CODE.



Once the "fourth" digit has been entered, when pressing button (4) the instrument panel activates the following indications:

- ◀ Back
- Memory (orange)

To exit the menu and go back to previous page highlight the "◀ Back" indication and press button (4). To memorise the entered code, highlight the "Memory" indication (orange) and press button (4). Then, the instrument panel will activate the "Memorised" indication (green) for 2 seconds.

At the end of the 2 seconds, the instrument panel goes back to the previous screen. To exit the menu and go back to previous page highlight the "◀ Back" indication and press button (4).

### Note

You can change your PIN CODE an unlimited number of times.

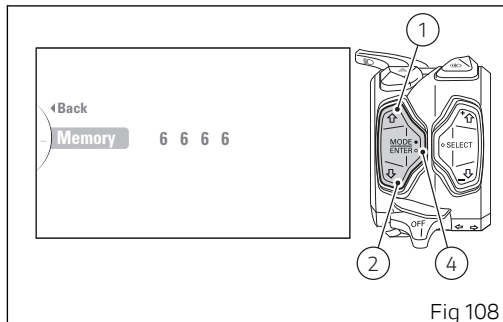

Fig 108



Fig 109

## Lap

Enter the SETTING MENU.

Select **Lap** option, by pressing button (1) or (2). Once function is displayed, press button (4).

You open the LAP Menu.

The following indications will be displayed in this page:

- ◀ Back
- On
- Off
- Lap Data
- Erase All (\*)
- ◀ Back

(\*) This indication is visible only if one or more saved LAPs are present.

Use buttons (1) and (2) to select the indication and press button (4) to activate the relevant function.

- If the indication is **"On"** the instrument panel activates the Lap Function; once it is activated, it is possible to record the LAP time (ref. page 0 );
- If the indication is **"Off"** the instrument panel disabled the Lap function;

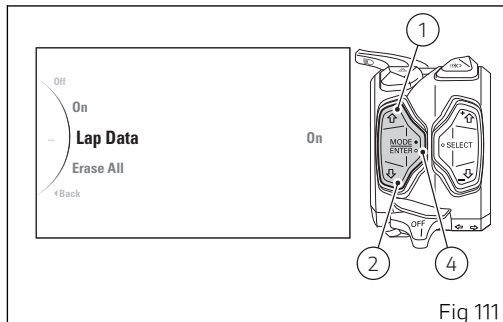
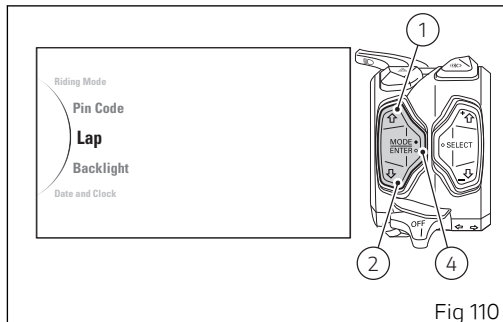

- If the indication is "**Lap Data**", the instrument panel shows the memorised LAPs (ref. to paragraph "**Displaying the stored LAPs**");
- If the indication is "**Erase All**", the instrument panel erases all memorised LAPs (ref. to paragraph "**Erasing the stored LAPs**").

### **Note**

In the event of an interruption of the power supply from the battery, when power is restored at the next Key-On, the system sets the LAP function automatically to the "Off" mode.

To exit the menu and go back to previous page highlight the "◀ **Back**" indication and press button (4).

## Displaying the stored Laps

The laps previously stored can be displayed. The information displayed is lap time, maximum rpm and top speed.

To view the LAPs, enter the SETTING MENU, use buttons (1) and (2) to select "**Lap**" and press button (4). Then use buttons (1) and (2) to select "**Lap Data**" and press button (4).

If there are no memorised LAPs, when accessing this page the instrument panel will show "◀Back" and "No Lap".

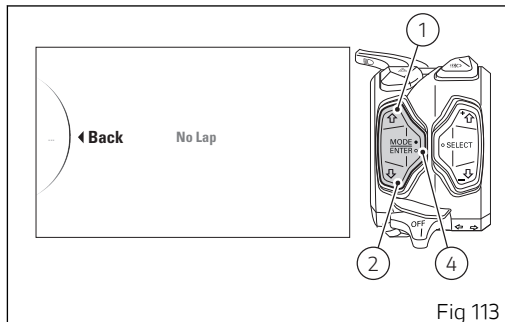
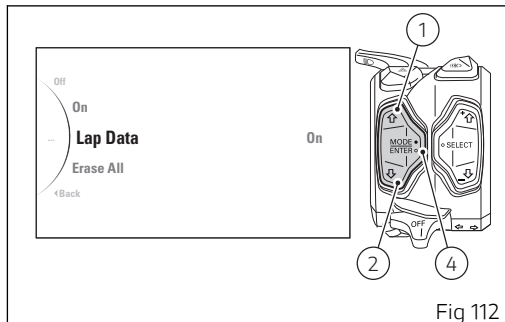

If there are memorised LAPs, when accessing this page the instrument panel will show the following information:

- ◀ Back
- Lap 01
- .....
- Lap 15
- ◀ Back

With buttons (1) or (2) it is possible to select one information. The displayed LAPs are only the recorded ones. For each memorised LAP, the display shows also:

- the word "Time" followed by the recorded LAP time (minutes – seconds – hundredths of second);
- "Speed Max" indication followed by the top speed recorded during the lap;
- "Rpm Max" indication followed by the engine rpm value reached in the recorded lap.

It is possible to record maximum of 15 LAPs.

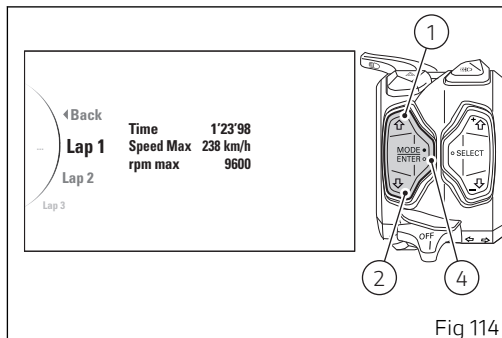

To exit the menu and go back to previous page highlight the "◀ Back" indication and press button (4).



#### Note

The MAX stored speed is reached during lap (increased by 5%).

## Erasing stored Laps

The memorised laps can be erased with the “Erase All” function.

To delete the LAPs, enter the SETTING MENU, use buttons (1) and (2) to select “Lap” and press button (4). Then use buttons (1) and (2) to select “Erase All” and press button (4).

When entering this display mode, if there is no memorised LAP, the instrument panel will show no indication allowing the erasing function; otherwise, it will display “Erase All”.

Use buttons (1) and (2) to select “Erase All” and press button (4).

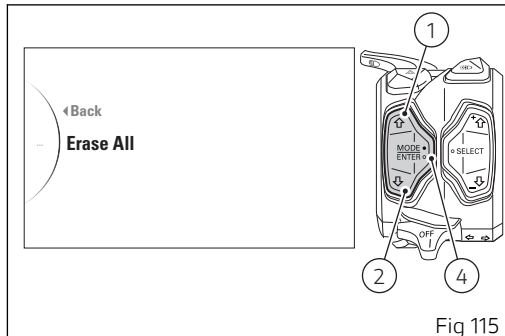

After confirming the "Erase All" function, the instrument panel shows:

- "Wait..." for 2 seconds;
- and then "Erase OK" for 2 seconds to inform about the result of the deletion process.

Deletion is one single command that erases all stored laps.

To exit the menu and go back to previous page highlight the " ◀ Back" indication and press button (4).

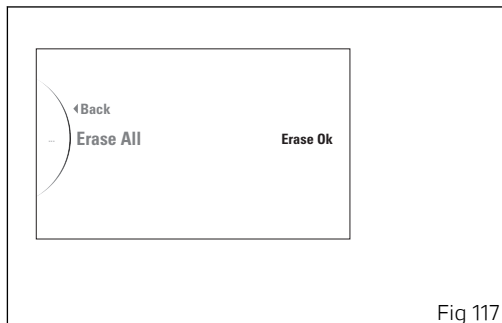
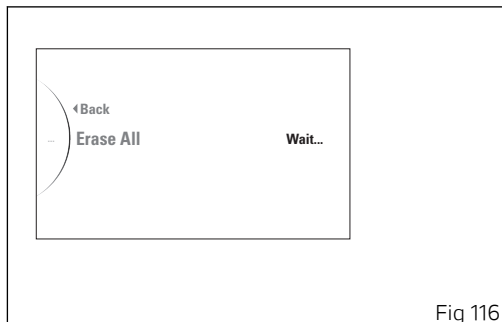

## Backlighting setting (Backlight)

This function allows adjusting the backlighting intensity.

To customise the background configuration, enter the SETTING MENU, use buttons (1) and (2) to select "**Backlight**" and press button (4).

As you enter this function, the instrument panel displays the following indications:

- ◀ Back
- Auto
- Day
- Night
- ◀ Back

With buttons (1) and (2) it is possible to select the desired display backlight.

Once the desired backlight is highlighted, press confirm button (4) to memorise the new selection.

To exit the menu and go back to previous page highlight the "◀ **Back**" indication and press button (4).

Select AUTO (automatic mode) to automatically adjust background colour according to ambient light (detected by a sensor). If the external lighting is

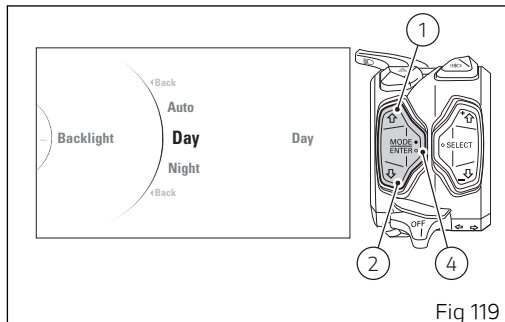
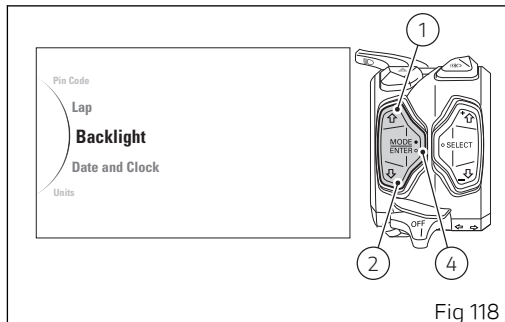

strong, the display will switch to white background; if the external lighting is poor, the display will switch to black background ”.

Select DAY (day mode) to permanently set display "white" background for improved readability - recommended in conditions of strong ambient light. Select NIGHT (night more) to permanently set display black background for dimmed visibility - recommended in case of poor ambient light and/or at night.



### **Note**

In case of battery off, when the voltage is restored and upon next Key-On, back lighting will always be set on "AUTO" mode.

## Date setting (Date and Clock)

This function allows user to set or change the date. Enter the SETTING MENU.

Use buttons (1) and (2) to select "Date and Clock" and press button (4).

As you enter this function, the instrument panel displays the following indications:

- ◀ Back
- Date
- Clock
- ◀ Back

Use buttons (1) and (2) to select "Date": when this indication is highlighted, the instrument panel displays the date in the set format: YEAR, MONTH, DAY (e.g.: 2016/01/20).

### Note

If nobody set the date, display will read dashes "- -" as year, month and day.

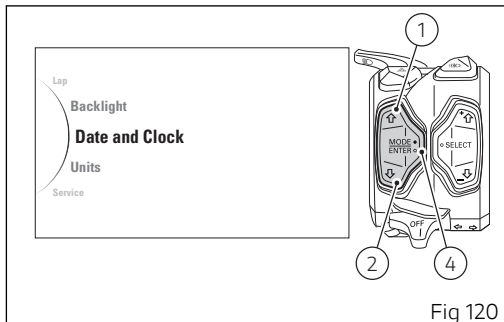

Fig 120

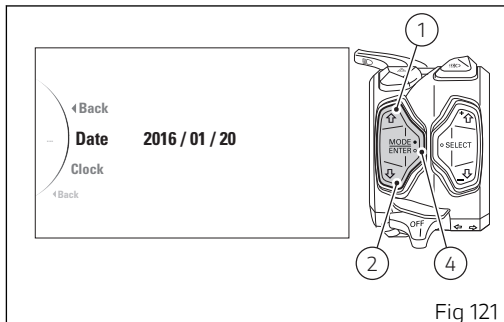

Fig 121

Highlight the **"Date"** indication and press button (4). When two arrows are displayed on the year indication, they give the possibility to set it:

- Press button (1) to increase year value by 1 ("2000", "2001", ..... "2099", "2000");
- Press button (2) to decrease year value by 1 ("2099", "2098", ..... "2000", "2099");
- once you reach the year to be set, press button (4) to confirm: the arrows move to the "month" value to allow setting it.

When two arrows are displayed on the month indication, they give the possibility to set it:

- press button (1) to increase the month by 1 ("01", "02", ..... "12", "01");
- press button (2) to decrease the month by 1 ("12", "11", ..... "01", "12");
- once you reach the month to be set, press button (4) to confirm: the arrows move to the "day" value to allow setting it.

When two arrows are displayed on the day indication, they give the possibility to set it:

- press button (1) to increase the day by 1 ("01", "02", ..... "31", "01");

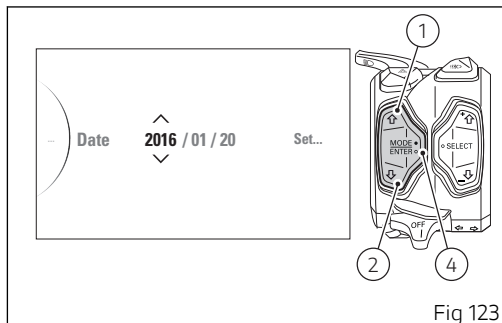
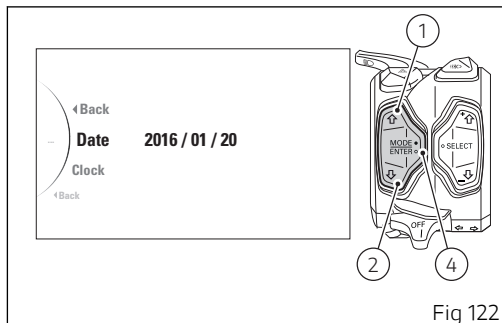

- press button (2) to decrease the day by 1 ("31", "30", ..... "01", "31");
- once you reach the day to be set, press button (4) to confirm.

After pressing button (4) to confirm the day, the instrument panel saves the set / modified date and activates the indication " ◀ Back".

If date is not correct, the instrument panel will display "Wrong" for 3 seconds and then it will automatically highlight the year (with the two arrows) to set another date.

To exit the menu highlight the " ◀ Back" indication and press button (4).



### **Important**

Every time the battery is disconnected, the calendar date is reset and must be set again.

## Clock setting (Date and Clock)

This function allows user to set or adjust the time.

Enter the SETTING MENU.

Use buttons (1) and (2) to select "Date and Clock" and press button (4).

As you enter this function, the instrument panel displays the following indications:

- ◀ Back
- Date
- Clock
- ◀ Back

Use buttons (1) and (2) to select "Clock": when this indication is highlighted, the instrument panel displays the time in the set format: AM / PM, HOUR, MINUTE (e.g.: AM 10 : 25).

### Note

If nobody set the time, display will read dashes " - - " as hour and minutes.

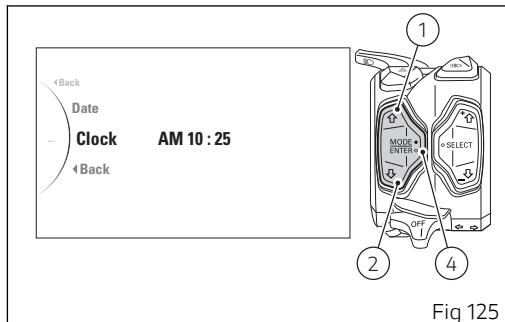
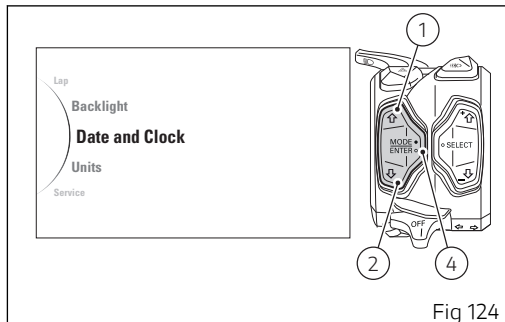

Highlight the **"Clock"** indication and press button (4). When two arrows are displayed on AM / PM, they give the possibility to set them:

- press button (1) to pass from "PM" to "AM";
- press button (2) to pass from "AM" to "PM";
- once you reach the desired value, press button (4) to confirm: the arrows move to the "hour" value to allow setting it.

When two arrows are displayed on the HOUR indication, they give the possibility to set it:

- use button (1) to increase by 1 the hour value ("11", "0", "1" ..... "11" for AM and "12", "1", ..... "12" for PM);
- Use button (2) to decrease by 1 the hour value ("0", "11", ..... "1", "0" for AM and "12", "11", ..... "1", "12" for PM);
- once you reach the desired value, press button (4) to confirm: the arrows move to the "minutes" value to allow setting it.

When two arrows are displayed on the MINUTE indication, they give the possibility to set it:

- press button (1) to increase minutes by 1 ("00", "01", ..... "59", "00");

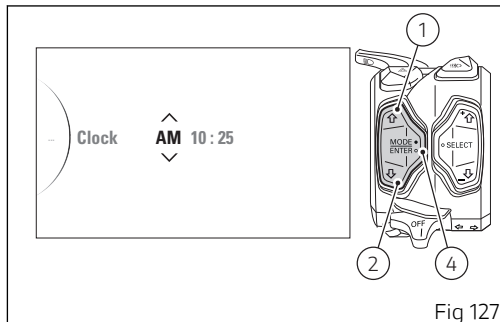
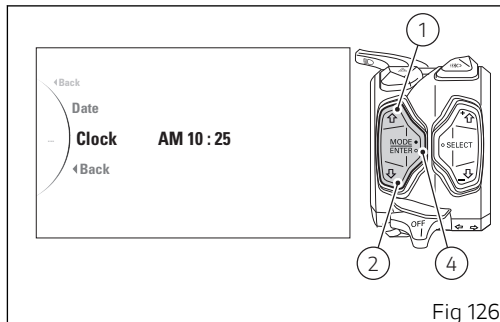

- press button (2) to decrease minutes by 1 ("59", "58", ..... "00", "59");
- once you reach the desired value, press button (4) to confirm: the arrows move to the "minutes" value to allow setting it.

After pressing button (4) to confirm the minutes, the instrument panel saves the set / modified time and activates the indication " ◀ **Back**".

To exit the menu highlight the " ◀ **Back**" indication and press button (4).

### **Note**

Every time the battery is disconnected, the clock is reset and must be set again by the user.

## Unit of measurement setting (Units)

This function allows changing the units of measurement of the displayed values.

Enter the SETTING MENU.

Use buttons (1) and (2) to select "**Units**" and press button (4).

As you enter this function, the instrument panel displays the following indications:

- ◀ Back
- Speed
- Temperature
- Consumption
- All Default (\*)
- ◀ Back

(\* ) This indication is visible only if one or more parameters have been modified.

Measurements for which it is possible to change the unit are the following:

- Speed;
- Temperature;
- Fuel consumption.

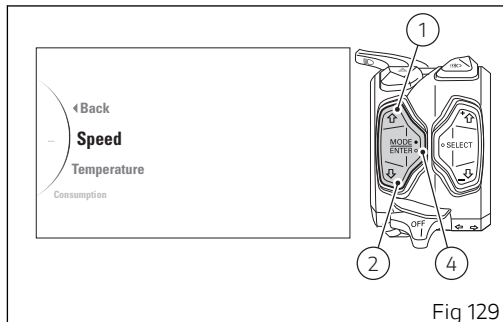
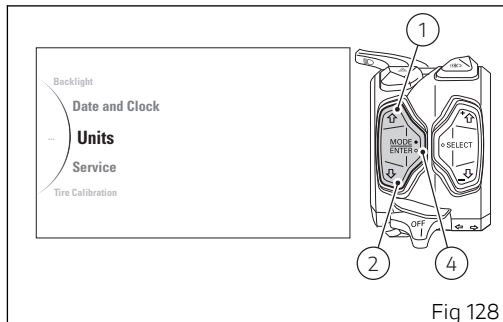

With buttons (1) and (2) it is possible to select the measurement of which you wish to change the unit:

- if the indication is "**Speed**", press button (4) to customise the Speed unit of measurement;
- if the indication is "**Temperature**", press button (4) to customise temperature unit of measurement;
- if the indication is "**Fuel consumption**", press button (4) to fuel consumption unit of measurement;
- if the indication is "**All Default**", press button (4) to restore all values of the units of measurements of all displayed measurements.

To exit the menu and go back to previous page highlight the " ◀ **Back**" indication and press button (4).

## Setting the units of measurement: Speed

This function allows to change the units of measurement of speed (and hence even the ones of distance travelled).

As you enter this function, the instrument panel displays the following indications:

- ◀ Back
- km/h
- mph
- Default (\*)
- ◀ Back

(\*) This indication is visible only if the set parameter is different from the "default" parameter.

With buttons (1) and (2) it is possible to select the desired measurement or "Default" to reset the default unit of measurement.

Once the desired function is highlighted, press button (4) to save the selected unit.

To exit the menu and go back to previous page highlight the "◀ Back" indication and press button (4).

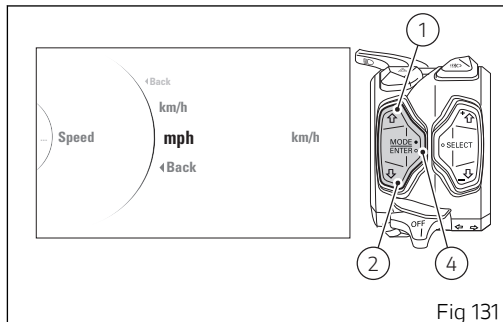
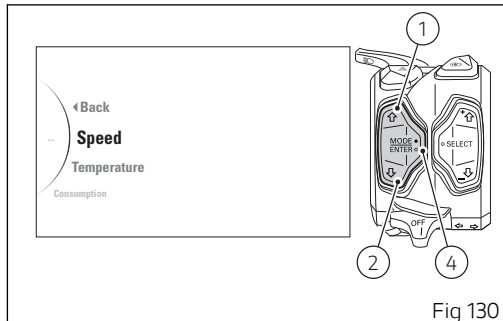

## Setting the units of measurement: Temperature

This function allows you to change the units of measurement of the temperature.

As you enter this function, the instrument panel displays the following indications:

- ◀ Back
- °F
- °C
- Default (\*)
- ◀ Back

(\*) This indication is visible only if the set parameter is different from the "default" parameter.

With buttons (1) and (2) it is possible to select the desired measurement or "Default" to reset the default unit of measurement.

Once the desired function is highlighted, press button (4) to save the selected unit.

To exit the menu and go back to previous page highlight the "◀ Back" indication and press button (4).

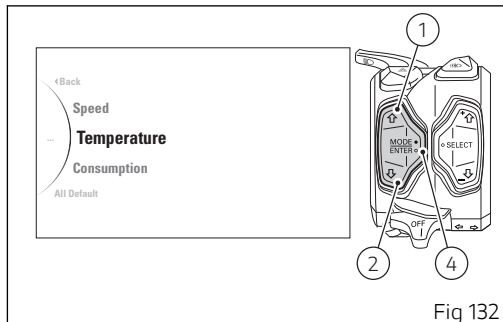

Fig 132

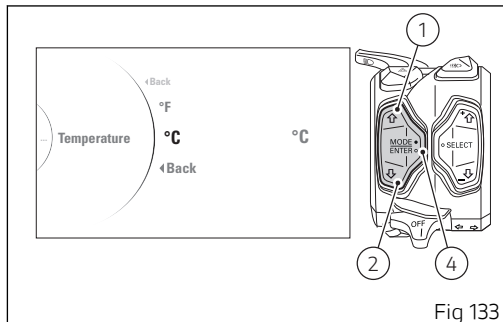

Fig 133

## Setting the units of measurement: Fuel consumption

This function allows you to change the units of measurement of the fuel consumption.

As you enter this function, the instrument panel displays the following indications:

- ◀ Back
- l/100
- Km/l
- mpg UK
- mpg US
- Default (\*)
- ◀ Back

(\*) This indication is visible only if the set parameter is different from the "default" parameter.

With buttons (1) and (2) it is possible to select the desired measurement or "Default" to reset the default unit of measurement.

Once the desired function is highlighted, press button (4) to save the selected unit.

To exit the menu and go back to previous page highlight the "◀ Back" indication and press button (4).

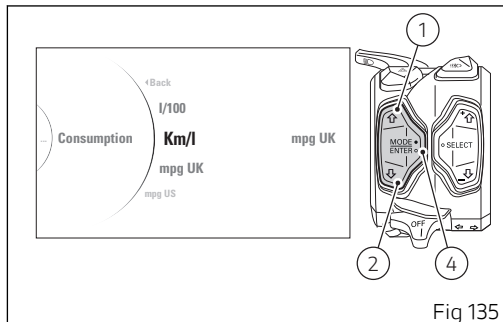
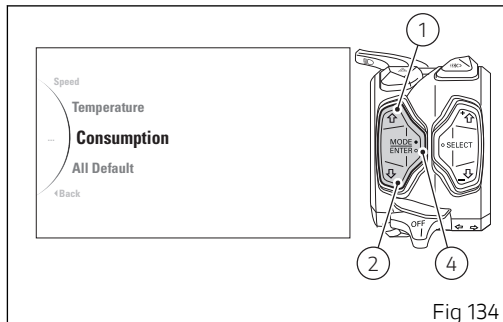

## Service thresholds display (Service)

This function informs the user on the deadlines for the indications of Oil Service (in Km or miles), Desmo Service (in Km or miles) and Annual Service (date). Enter the SETTING MENU.

Use buttons (1) and (2) to select "**Service**" and press button (4).

When entering this function, the instrument panel will list for each type of maintenance the relevant indication upon reaching the maintenance threshold:

- Oil service with logo and mile (or km) countdown to the next OIL SERVICE;
- Desmo service with logo and mile (or km) countdown to the next DESMO SERVICE;
- Annual service with logo and Annual Service expiration date.

To exit the menu and go back to previous page highlight the "**◀ Back**" indication and press button (4).

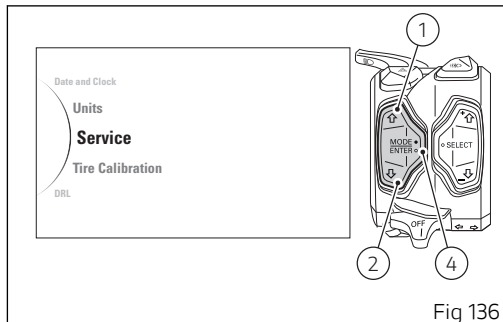

Fig 136

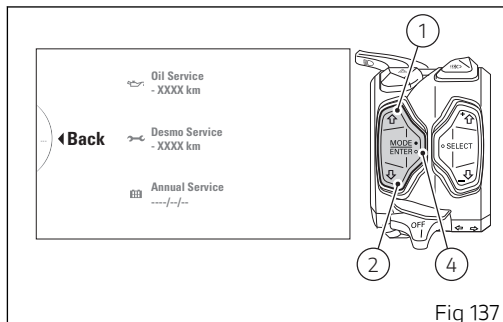

Fig 137

## Tyre setting and drive ratio (Tyre Calibration)

This function allows the user to run the procedure for calibrating and teaching in the tyre rolling circumference and final drive ratio.

Enter the SETTING MENU.

Select "**Tyre Calibration**" option, by pressing button (1) or (2).

Once function is highlighted, press button (4).

As you enter this function, the instrument panel displays the following indications:

- ◀ Back
- Start
- Default (this indication is visible only if the set parameter is different from the "default" parameter)

To exit the menu and go back to previous page highlight the "◀ **Back**" indication using button (1) or (2) and press button (4).

To start the drive ratio and tyre calibration procedure press button (4) when "**Start**" is highlighted.

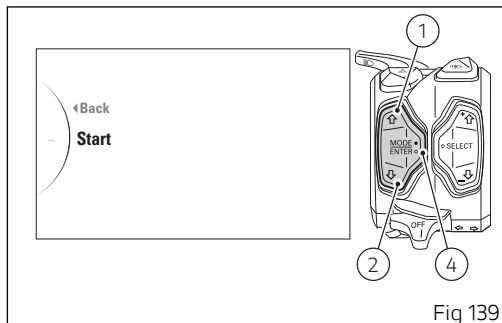
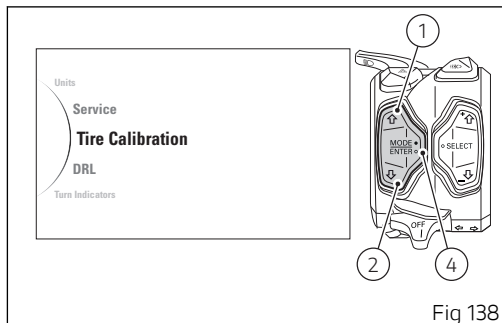

When the calibration procedure starts, the instrument panel displays the message "**Ready**" flashing, the message "**Keep Speed**" with speed range and the gear to be maintained by the user to complete the teach-in procedure. On the right the reference Riding Mode, current speed and gear engaged.

### Important

The teach-in procedure is allowed only at a vehicle speed between 48 Km/h (30 mph) and 52 Km/h (32 mph) in the 2rd gear.

When the rider complies with the required conditions of vehicle speed and gear displayed, the instrument panel starts system calibration: all previous information will be displayed showing "**In progress**" instead of "Ready".

Calibration is performed by keeping speed and gear within the indicated range for 5 seconds.

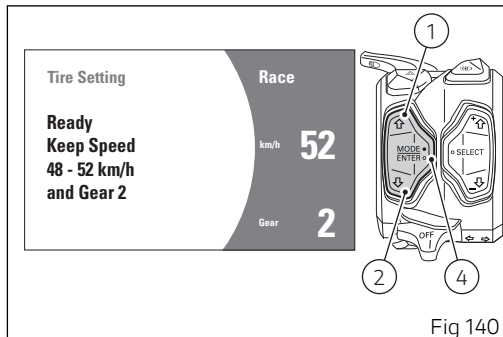

Fig 140

If the teach-in procedure is completed correctly, the instrument panel shows **“Completed”** followed by the previous screen after a few seconds.

### Note

During the calibration procedure, if the vehicle speed exceeds 62 mph (100 km/h), the procedure will stop.

### Note

During calibration, the procedure can be aborted and user can go back to standard screen by pressing button (1) for 2 seconds.

If the calibration procedure is aborted by the user, the instrument panel shows **“Aborted”** followed by the previous screen after a few seconds.

If, on the other hand, an error or malfunction occurs during the calibration procedure, the instrument panel shows **“Failed”** followed by the previous screen after a few seconds.

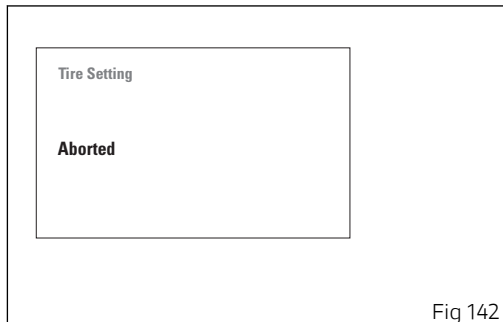
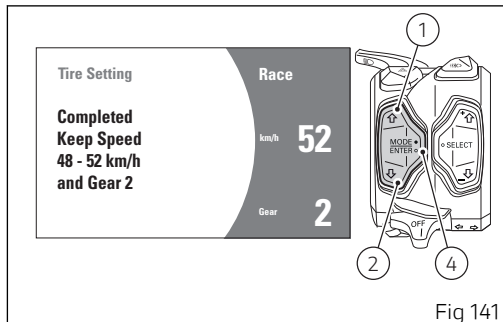

To reset to the default settings, use buttons (1) and (2) to select "**Default**" and press button (4). Now the instrument panel shows "Default Please Wait.." and after a while "Default Default Ok" for 2 seconds, then followed by the previous screen.

 **Note**

If during the calibration procedure a vehicle key-off is performed, the procedure will stop and end with negative result.

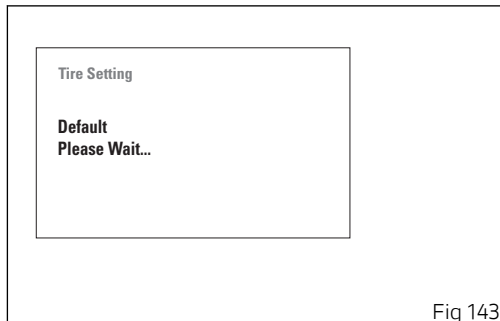

Fig 143

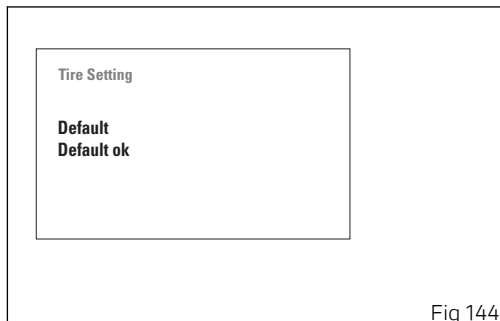

Fig 144

## DRL light mode setting (DRL)

This function, active only if the DRL is available, allows the user to choose the DRL status: AUTO or MANUAL; the DRL lights are not present in China, Canada and Japan versions.

Enter the SETTING MENU.

Select “DRL” option, by pressing button (1) or (2).  
Once function is highlighted, press button (4).

As you enter this function, the instrument panel displays the following indications:

- ◀ Back
- Manual
- Auto
- ◀ Back

Use buttons (1) and (2) to select the desired setting:

- by selecting “**AUTO**” the DRL lights, the high and/or low beams are automatically switched from the DAY mode to the NIGHT mode and vice versa according to the ambient light;
- by selecting “**Manual**” the automatic management of DRL lights is disabled.

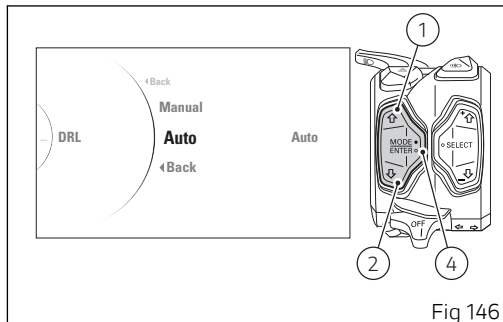
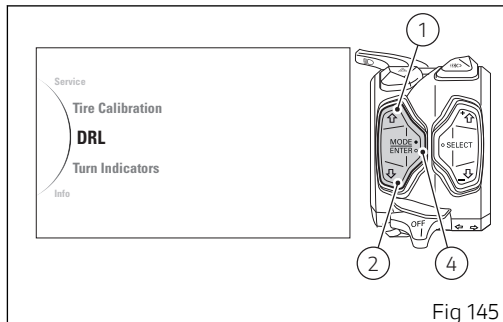

Once the desired function is highlighted, press button (4) to set the selected mode.

To exit the menu and go back to previous page highlight the " ◀ **Back**" indication and press button (4).



### Note

This setting ("AUTO" or "MANUAL") remains stored even after Key-Off. In the event of an interruption of the power supply from the battery (Battery Off), when power is restored at the next Key-On, the mode will always be set by default to the "AUTO" mode.

## Bluetooth device setting (Bluetooth)

This function allows pairing the Bluetooth devices and/or deleting them if necessary: the function is active only when the Bluetooth control unit is available. In this model it is not available, but it can be purchased at a Ducati Dealer or Authorised Service Centre.

Enter the SETTING MENU.

Use buttons (1) and (2) to select "**Bluetooth**" and press button (4).

As you enter this function, the instrument panel displays the following indications:

- ◀ Back
- Associated Devices
- Pairing
- ◀ Back

Use buttons (1) and (2) to select the desired function:

- if "**Associated Devices**" is highlighted, press button (4) to view the list of associated Bluetooth devices, as described in paragraph "Associated devices display";

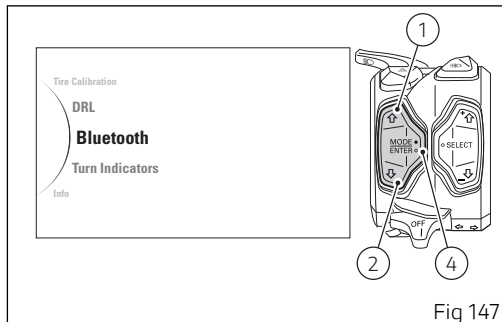

Fig 147

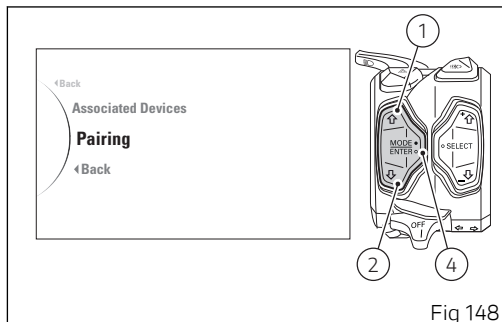

Fig 148

- if "Pairing" is highlighted, press button (4) to pair new devices, as described in paragraph "Search and pairing of a new device".

## Search and pairing of a new device (Pairing)

To perform the "Pairing" procedure of one or more Bluetooth devices it is necessary to set the device to ensure it can be detected by the control unit, so turn device on and make it visible to other devices.

A Bluetooth device in visible mode transmits a wireless signal allowing it to be detected by other devices. This function is called pairing mode.

The motorcycle can be equipped with a Bluetooth control unit that works as a hub between the various supported electronic devices relying on a Bluetooth communication interface.

### Attention

Bluetooth Headset device manufacturers may incorporate certain changes within the standard protocols over the course of the lifecycle of the device (Smartphones and Earphones).

### Attention

These changes are outside the control of Ducati and may result in Bluetooth Headset devices functionality becoming impaired (sharing Music, multimedia player, etc.) and may equally affect some types of Smartphones (depending on supported Bluetooth profiles). This is why Ducati cannot guarantee multimedia player proper operation for:

- any earphones not coming with the "Ducati Kit part no. 981029498";
- any Smartphones not supporting the required Bluetooth profiles (even though paired to earphones coming with the "Ducati Kit part no. 981029498").

### Attention

In case of interference or noise due to particular conditions of the external environment, the Ducati earphone kit part no. 981029498 also allows sharing the music being played directly from rider helmet to passenger helmet (for further details please refer to the manual of the earphones coming with the Ducati kit part no. 981029498).



## Note

The Ducati kit part no. 981029498 can be purchased separately at a Ducati Dealer or Authorised Service Centre.

To perform pairing procedure use buttons (1) and (2) to select "Pairing" and press button (4).

As you enter this function, the instrument panel displays the following indications:

- ◀ Back
- Smartphone
- Rider
- Passenger
- Navi
- ◀ Back

Use buttons (1) and (2) to select the type of device for which you wish to start the device search procedure. Once the device is highlighted, press button (4).

To exit the menu highlight the "◀ Back" indication and press button (4).

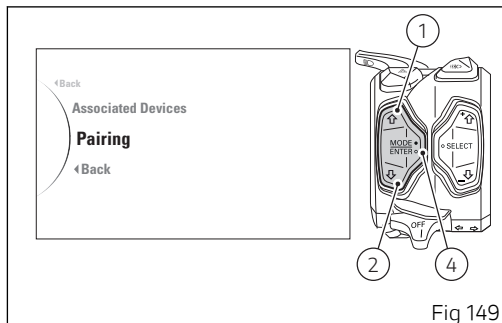

Fig 149

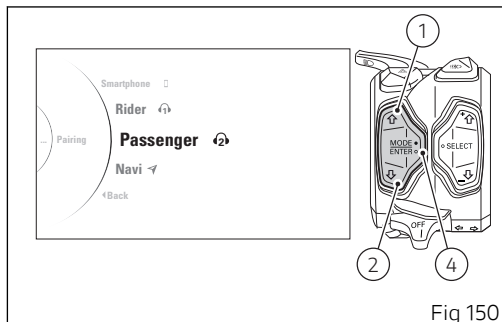

Fig 150

The instrument panel displays the relevant icon for each device type, namely:

- Smartphone 📱
- Rider 🎧 (Rider intercom)
- Passenger 🎧 (Passenger intercom)
- Navi 📍 (navigator)

The instrument panel displays "Wait..." during device search phase. The pairing ends automatically when devices are detected within the range. This search phase takes 60 seconds.

At the end of this operation, a list of all found devices that can be paired is displayed: the list can show a maximum of 20 devices.

## Note

The list of devices found within the range during the pairing stage does not include already paired devices even if their Bluetooth connection is ON.

With buttons (1) and (2) select the indication of the device you wish to pair.

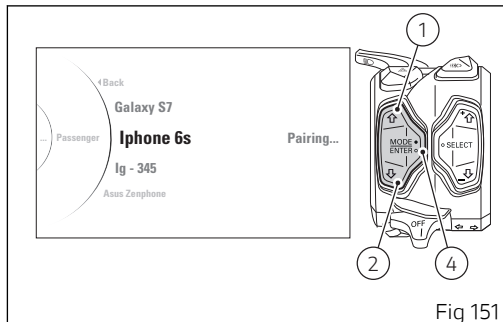

Fig 151

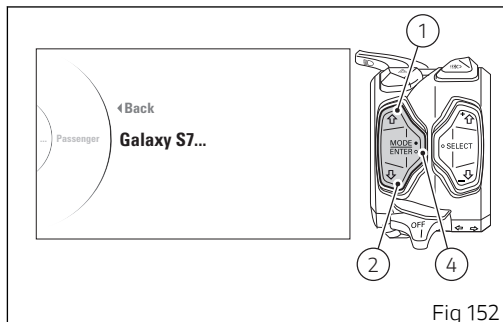

Fig 152

Once the device is chosen, highlight it and press button (4).

The instrument panel shows "Pairing": to confirm the selected device Pairing press button (4) again. If you do not wish to proceed with pairing, highlight the "◀ Back" indication and press button (4). By confirming the device pairing, the instrument panel will display "Wait...". As soon as the procedure is completed, the device is added to the list of associated devices.

If Pairing is not successful, the "Pairing error" message will be displayed.

If you wish to connect a Bluetooth navigator, the connection procedure shall be completed on the navigator, by selecting the connection with the motorcycle Bluetooth control unit. If user does not complete the pairing procedure on the Navigator side within 90 seconds, pairing procedure cannot be completed.

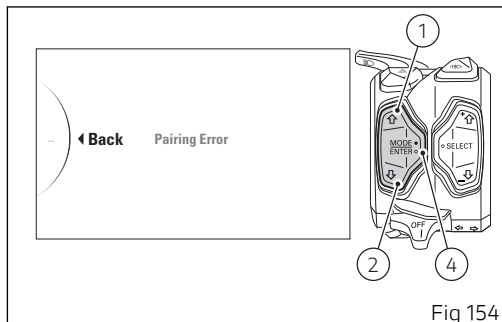
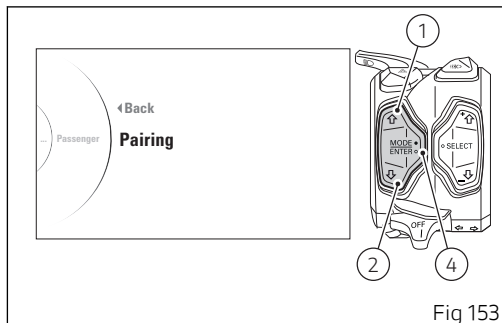

## Associated Devices display

To view the devices already associated, access the **SETTING MENU**, use buttons (1) and (2) to select "Bluetooth" and press button (4). Use buttons (1) and (2) to select "**Associated Devices**" and press button (4).

A list of all associated devices is displayed: the list can show a maximum of 5 devices. For each device the relevant icon indicating the type is shown on the side.

To exit the menu highlight the "◀ **Back**" indication and press button (4).

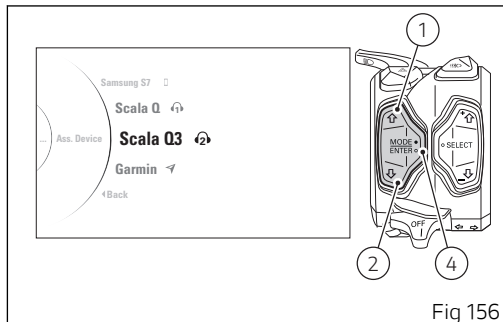
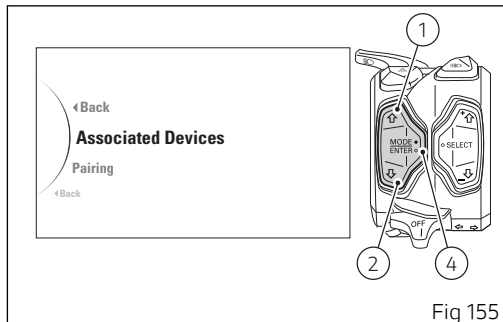

If no associated devices are present, the instrument panel will show "No Device".

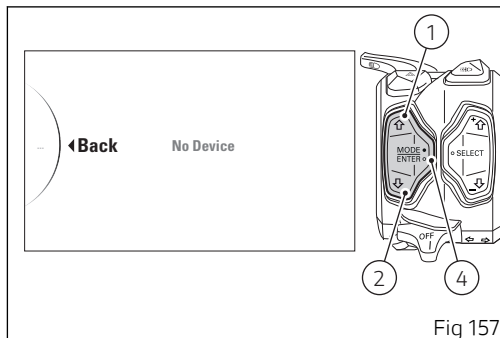

## Deleting associated device(s)

This function allows the user to delete a device from the list of paired devices.

Access the already associated devices page, use buttons (1) and (2) to select "Associated Devices" and press button (4).

Use buttons (1) and (2) to highlight and select the device to be deleted from the list. Press button (4).

The instrument panel shows "Delete" and press button (4) again to confirm.

If you do not wish to delete it, highlight the "◀ Back" indication and press button (4).

By confirming the device deletion, the instrument panel will display "Wait...".

As soon as the procedure is completed, the device is removed from the list of associated devices.

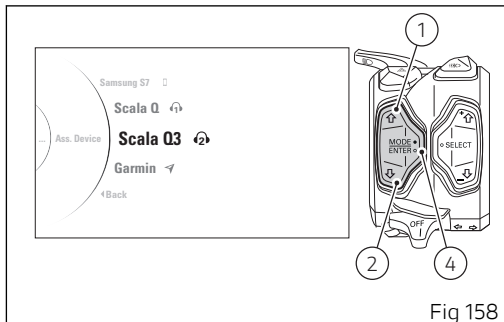

Fig 158

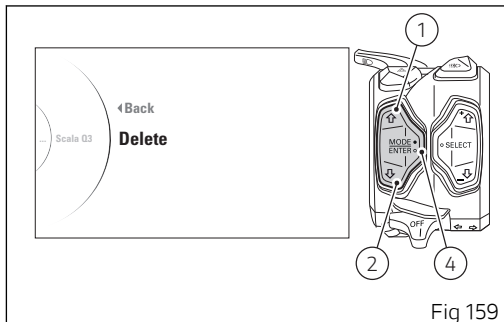

Fig 159



## Attention

Ducati does not ensure a correct connection to the Ducati Multimedia System of Bluetooth navigators that are not provided in the following kits:

- Kit of Ducati Zumo satellite navigator 350
- Kit of Ducati Zumo satellite navigator 390
- Kit of Ducati Zumo satellite navigator 395



## Note

The Ducati kits mentioned above can be purchased separately at a Ducati Dealer or Authorised Service Centre.

## DDA

This function allows you to enable and disable the DDA, view the percentage of memory used and to delete data stored in the DDA (Ducati Data Analyzer) memory.

The page for the DDA is only available when the device is fitted to the motorcycle.

Enter the SETTING MENU.

Select "DDA" option, by pressing button (1) or (2).

Once function is highlighted, press button (4).

As you enter this function, the instrument panel displays the following indications:

- ◀ Back
- Off
- On
- Memory
- ◀ Back

The currently set DDA status is also indicated on the right (e.g.: DDA Off).

Use buttons (1) and (2) to select the desired setting:

- if "Off" is selected, press button (4) to deactivate DDA;

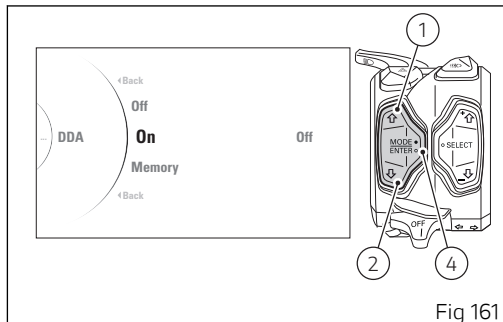
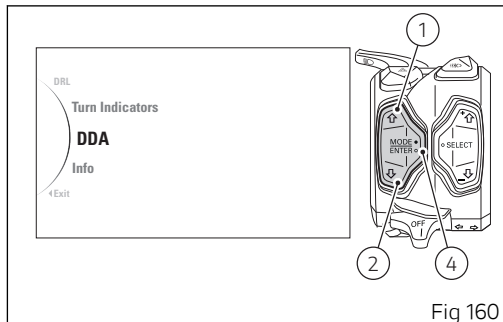

- if "**On**" is selected, press button (4) to activate DDA;
- if "**Memory**" is selected, press button (4) to display or delete DDA memory.

To exit the menu and go back to previous page highlight the " ◀ **Back**" indication and press button (4).



### **Note**

The DDA is automatically disabled by the instrument panel upon every Key-OFF.

Select "**Memory**" indication to display and/or delete data in DDA memory.

As you enter this function, the instrument panel displays the following indications:

- ◀ Back
- Erase (\*).

The current DDA memory status is also displayed on the right as a percentage:

- when bar is empty and reads Empty 0%, DDA memory is not empty;
- when bar is partially coloured and a percentage is specified, DDA memory is full by the indicated percentage;
- when bar is completely coloured and reads Full 100%, DDA memory is completely full.

(\* The "Erase" indication is displayed only if DDA memory is not empty.

To delete the memory, use button (1) or (2) to select **Erase** and press button (4).

The instrument panel will show "Wait..." for as long as the deletion is completed (depending on the quantity of data to be deleted).

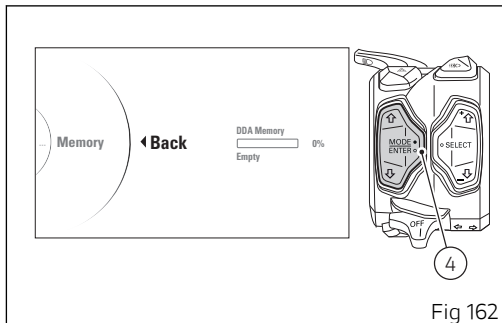

Fig 162

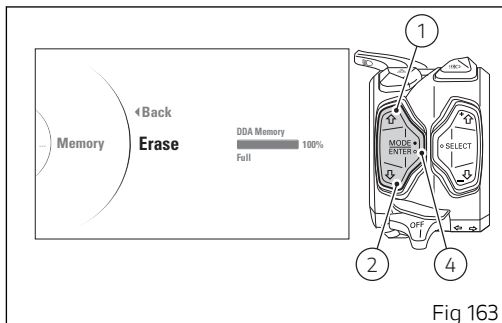

Fig 163

If deletion is successful, the instrument panel will read "Erase OK" for 3 seconds and refresh the memory status displayed. If deletion is not successful, the instrument panel will still show memory used status.

To exit the menu and go back to previous page highlight the " ◀ Back" indication and press button (4).



### **Attention**

Never leave DDA connected to wiring connector when the motorcycle is turned off, as the battery could run flat.

## Turn indicator automatic switch-off feature (Turn indicators)

This Function allows user to set the strategy for automatically switching off the turn indicators based on lean angle, vehicle speed and distance run to automatic mode (AUTO) or manual mode (MANUAL).

Enter the SETTING MENU.

Select **"Turn indicators"** by pressing button (1) or (2). Once function is highlighted, press button (4).

As you enter this function, the instrument panel displays the following indications:

- ◀ Back
- Auto
- Manual
- ▶ Back

Use buttons (1) and (2) to select the desired setting:

- by selecting **"Auto"**, the system activates the self-disabling strategy of the turn indicators;
- by selecting **"Manual"**, the system disabled the self-disabling strategy of the turn indicators (so the turn indicators can be turned off manually only by pressing the dedicated button).

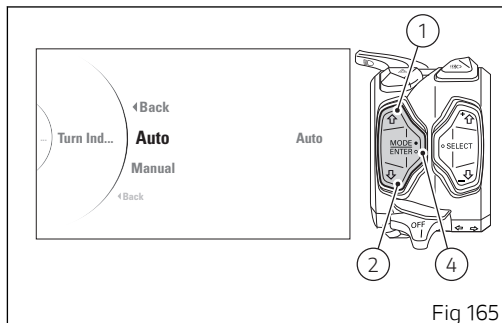
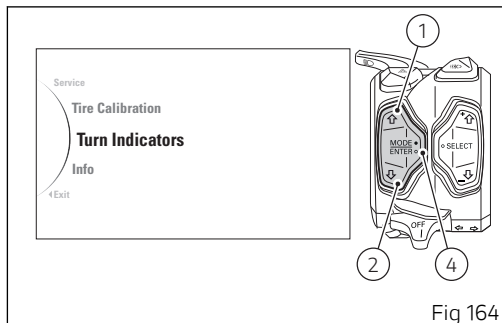

Once the desired function is highlighted, press button (4) to set the selected mode.

To exit the menu and go back to previous page highlight the " ◀ **Back**" indication and press button (4).

### **Note**

This setting ("AUTO" or "MANUAL") remains stored even after Key-Off. In the event of an interruption of the power supply from the battery (Battery Off), when power is restored at the next Key-On, the mode will always be set by default to the "AUTO" mode.

### **Note**

The strategy for automatically switching off the turn indicators is not active if all turn indicators are on at the same time (Hazard function).

### **Note**

At any moment, if the instrument panel finds that the ABS control unit is in "error", system will disable the set switch-off strategy (so turn indicators will not be cancelled automatically).

## Information (Info)

This Function allows viewing the vehicle battery voltage and the RPM "digital" indication.

Enter the SETTING MENU.

Select "**Info**" option, by pressing button (1) or (2).

Once function is highlighted, press button (4).

When entering this function, the instrument panel displays:

- "Battery" with battery voltage value;
- "rpm" with the number of engine rpm in digital format.

To exit the menu and go back to previous page highlight the "**◀ Back**" indication and press button (4).

"Battery" information is displayed as follows:

- if the battery voltage is equal to or lower than 10.9 V, the "LOW" message will be displayed in red and flashing;
- if battery voltage is between 11.0 V and 11.7 V the reading will be displayed in red and flashing;
- if battery voltage is between 11.8 V and 14.9 V the reading will be displayed steadily with the battery icon on a standard background;

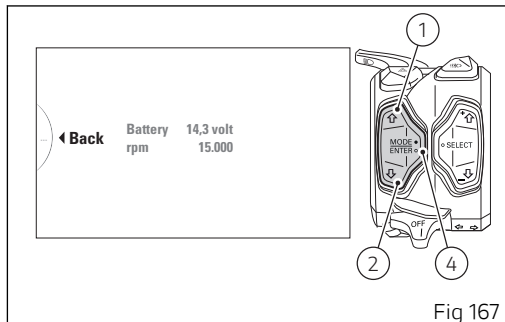
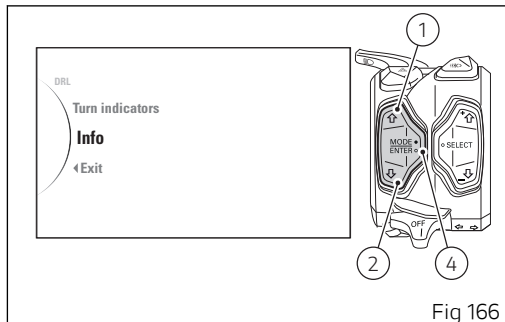

- if battery voltage is between 15.0 V and 16.0 V the reading will be displayed in red and flashing;
- if the battery voltage is equal to or higher than 16.1 V, "HIGH" will be displayed in red and flashing.

The engine "rpm" indication in digital format is recommended for improved accuracy when setting idle rpm.

The display shows the numerical value of the engine rpm with a precision of 50 rpm.

If the instrument panel is not receiving RPM value, a string of five steady dashes "- - - -" is displayed to indicate an undefined reading.

## Assisted start (Launch Control - DPL)

This Function allows activating the assisted start function (called DPL - Ducati Power Launch).

By pressing button (12) it is possible to access the Launch Control menu only if the vehicle speed is equal to or less than 5 Km/h (3 mph).

In the Launch Control menu, it is possible to select the desired DPL level (1, 2, 3) by pressing buttons (1) and (2), and to set the selected level by keeping button (4) pressed for 2 seconds.

### Note

If no change is made in this menu within ten seconds, the instrument panel will set DPL to OFF and go back to the previous screen.

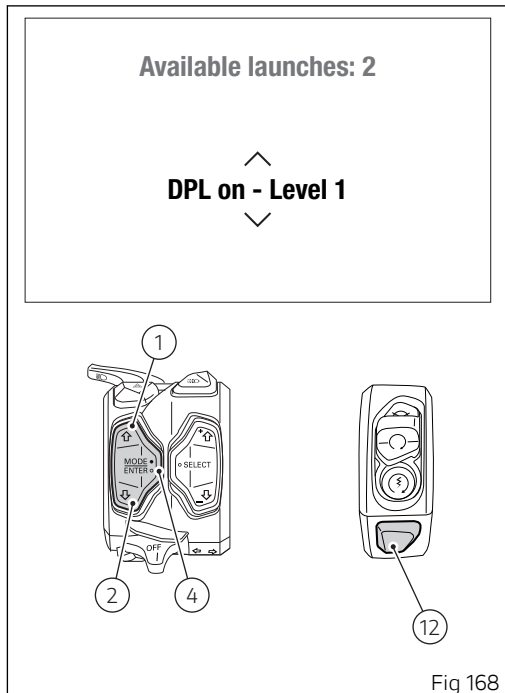

Fig 168

Once the DPL level is set, the instrument panel shows the wait screen for 1 second (Fig 169): during this time, if you press button (4) the wait phase is interrupted and the instrument panel displays the main screen and sets the DPL to OFF.

Then the instrument panel shows the "assisted launch" screen (Fig 170).

After the assisted start, the instrument panel sets the DPL to OFF and shows the "main screen" again. The DPL is set to OFF by default by Ducati.

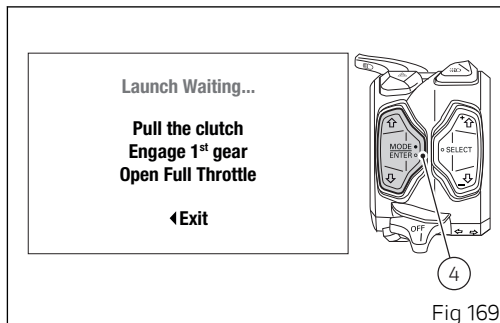

Fig 169

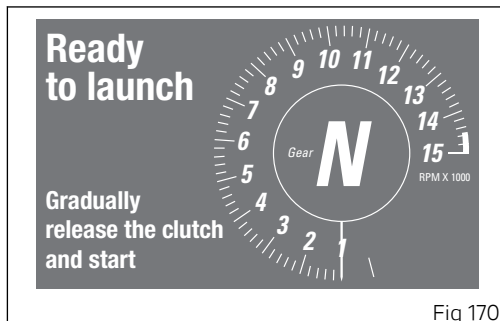

Fig 170

 **Note**

If the DTC is set to "OFF", the DPL function can not be activated.

If the DTC is set to OFF and you press button (12), the instrument panel shows for 5 seconds the indication DTC OFF – DPL NOT AVAILABLE; when the 5 seconds are over, the instrument panel goes back to the main screen.

 **Note**

If the instrument panel detects a control unit error when entering the DPL menu, regardless of the currently set display mode, it will show the blinking message LAUNCH CONTROL ERROR for three seconds and then again the main screen.

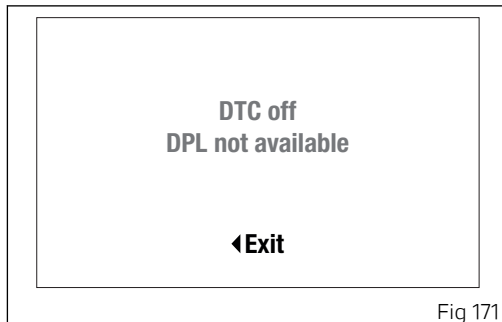

Fig 171

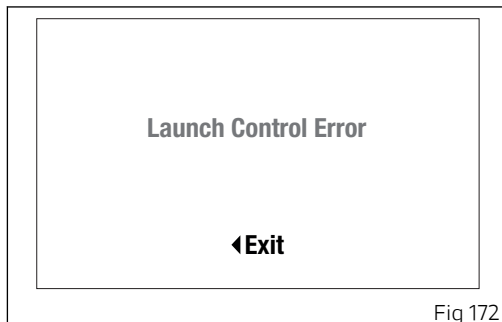

Fig 172



## Note

If the available launches are finished, the instrument panel shows the message NO LAUNCHES AVAILABLE.

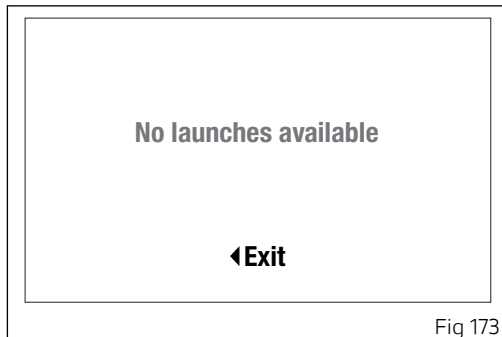

Fig 173

The Ducati Power Launch (DPL) helps the rider in the delicate sport starting phase from a standstill to control the power delivered by the vehicle.

The DPL system works with three intervention levels, each calibrated to offer a different start assist degree. The following table indicates the most suitable DPL intervention level depending on the various starting types. All levels are to be intended optimised for OEM (Original Equipment Manufactured) tyres.

DPL level	Performance	Use
1	High	Use focused on the best performance for very expert riders. The system allows the wheelie and the rear wheel slipping, but reduces the speed at which these two situations take place.
2	Medium	Use for expert riders. The system reduces the tendency to wheelie and rear wheel slipping, besides intervening considerably in case these two situations take place.
3	Medium	Use for all kinds of riders. The system minimises the tendency to wheelie and rear wheel slipping, besides intervening considerably in case these two situations take place.



## Attention

The DPL system is to be used exclusively on straight and level paths, on optimal grip conditions of the road.

The DPL system is conceived to be used within a controlled environment or in a closed circuit. For safety reasons it must not be used in unsuitable places.

### Starting procedure

The starting procedure basically consists of two phases:

- The first: with completely released clutch so that the torque transmitted to the ground depends on the clutch position and slipping;
- The second: with clutch not released so that the torque transmitted to the ground depends on the torque delivered by the engine.

The DPL system helps the rider to start from a standstill and during the first phase by automatically adjusting the torque delivered by the engine to keep the engine rpm at the ideal value to start. This allows the rider to concentrate only on the clutch release that must be progressive and "smooth" instead of

fast or abruptly. The engine torque is adjusted also in the second phase, by maximising the delivered power and limiting the vehicle wheeling or rear wheel slipping.

To preserve the clutch, the DPL system calculates in real time and shows in the dedicated menu on the instrument panel the number of starts that can be performed consecutively by decreasing it by one unit every time a start is completed. The DPL system increases the value by one unit according to the distance covered by the vehicle and the time during which the vehicle engine was on and off.

The DPL system allows performing other assisted starts only when the number of remaining starts is higher than zero.



## Attention

Using the DPL system could reduce the useful life of the engine and transmission mechanical parts. The DPL system should be used only when the engine has reached the operating temperature.

To perform an assisted start with the DPL, the rider must first of all set the vehicle in the following condition:

- vehicle speed at zero;
- vertical position;
- engine on;
- DTC set to ON.

If the count of the residual assisted starts is above zero, the rider can select on the instrument panel the desired DPL level by accessing the relevant menu through the dedicated button.

After selecting the level, the rider must pull the clutch, engage the first gear and fully open the throttle twistgrip.

If all operations indicated above have been performed, the DPL system will show a confirmation screen on the instrument panel indicating that the system is ready to start.

The rider must then release the clutch progressively by keeping the throttle twistgrip fully open.

When the vehicle speed exceeds 20 km/h, the instrument panel shows the standard screen while keeping the indication of the selected DPL system level for the entire duration of the start phase.

The DPL system is switched off when one of the following conditions is met after completely releasing the clutch:

- vehicle speed higher than 160 km/h;
- third gear engaged.

The DPL system is switched off also if, after releasing the clutch, the rider decides to interrupt the start phase by closing the throttle and bringing the vehicle speed under 5 km/h.

### Attention

The system manages the power delivered by the engine but not the clutch lever release that remains under the control of the rider.

During the starting phase, an abrupt release of the clutch will prevent an optimal behaviour of the vehicle. Likewise, a prolonged activation of the clutch may overheat and thus damage it.

### Attention

The rider position on the bike may influence the system behaviour.

Tips on how to select the intervention level

If level 3 is set, the DPL system intervenes by reducing the tendency to wheelie or rear wheel

slipping during the starting phase. Levels 2 and 1 provide a limited intervention of the system.

To identify the DPL level most suitable to your riding style we recommend to activate the system, select level 3 and perform a start to become familiar with the system. Then we recommend to try levels 2 and 1 in sequence until finding the best intervention.

If non-OEM tyres of a different size class are used or if the tyre size differs significantly from the original tyres, it may be that the system operation is compromised.

As far as tyres are concerned, in the case of minor differences such as, for example, tyres of a different make and/or model than the OE ones, it is necessary to use the relevant automatic calibration function in order to restore correct system operation.



## Attention

The DPL is a rider assist system. The system is designed to make riding easier and to enhance safety, but in no way relieves the rider of the obligation to drive responsibly and to maintain a high standard of riding in order to avoid accidents, whether caused by his own errors or those of other road users, through making emergency manoeuvres, in accordance with the prescriptions of the road traffic code.

The rider must always be aware that active safety systems have a preventive function. The active elements help the rider control the motorcycle, making it as easy and safe to ride as possible. The presence of an active safety system should not encourage the rider to ride at speeds beyond the reasonable limits, not in accordance with the road conditions, the laws of physics, good riding standards and the requirements of the road traffic code.

## LAP Time

The LAP function is available for the TRACK layout (only. LAP function information is available when the function is activated through the Function Menu or through the Setting Menu. When selecting screen view in TRACK mode, the LAP function is displayed automatically. Upon activation of the LAP function, the display shows the timer with the first indication "0'00'00" and the LAP number with the first indication "LAP -- " (

Upon the first press on FLASH button (3) the timer starts with a resolution of one tenth of a second ("0'00'0") and the screen displays the current LAP number, both information flash for 1 second and then remain steady on.

Every time the FLASH button (3) is pressed again, the display shows the number and time of the just-ended lap for 1 second, both flashing for 1 second, then they remain steady on for further 5 seconds. If lap time is the Best Lap, the number and time of the just-ended lap will both be shown flashing for 6 seconds. Then the timer and the number of the new current lap (Fig 175) are displayed again.

If lap timer is active but motorcycle is at standstill, lap timer is stopped after 5 seconds and it is

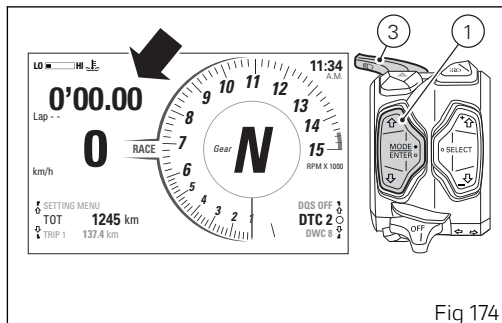

Fig 174

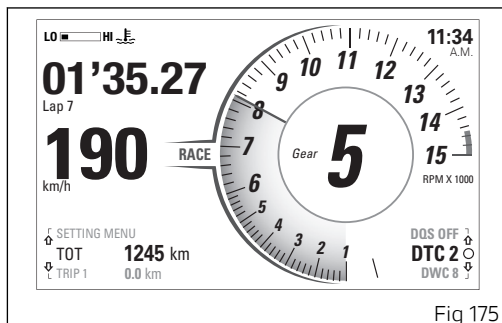

Fig 175

displayed with the initial indication "0'00'00" and the LAP number "LAP – –". The next time rider pushes the FLASH button (3), the lap timer is reactivated.

- no. 15 values for max. speed (maximum speed value reached in every lap);



### Note

When the LAP function is active, the FLASH button takes on the dual function of high beam "FLASH" and LAP timer start / stop (new lap start indication).

It is possible to record the lap time, for a total of 15 consecutive laps.

Laps are numbered from 01 to 15: when lap 15 is reached, "FULL" is displayed when button FLASH (3) is pressed.

To delete the recorded laps, refer to LAP paragraph page 0 of Setting menu.

For each lap, the lap time, max RPM value and max speed value are memorised.

The instrument panel can record:

- no. 15 lap times (time between consecutive start and stop);
- no. 15 values for max. RPM (maximum RPM value reached in every lap);

## Infotainment

The Panigale V4 can fit the Ducati Multimedia System (DMS) only when the Bluetooth control unit is available (not present in this model); thanks to the DMS system the user can answer phone calls, select and listen to music tracks, and receive SMS notifications by means of the Bluetooth technology. In this model the Bluetooth control unit which is not present, can be purchased at a Ducati Dealer or Authorised Service Centre.



### Note

Download the Ducati Link app available for iOS and Android devices to activate different services such as: journey recording, motorbike data saving, motorbike maintenance data consultation, parameter setting and much more.

The instrument panel displays the Infotainment function status: Bluetooth activation and any connected devices (smartphone, earphones, navigator).

When the Bluetooth is active, the main screen displays the Bluetooth icon.

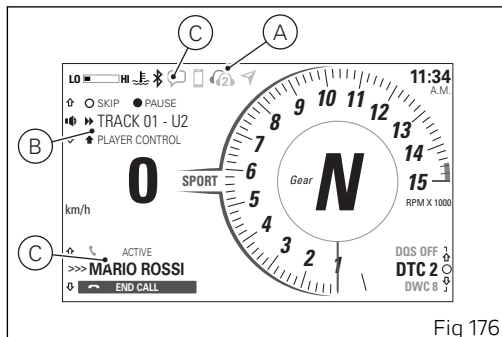

Fig 176

Furthermore, the Infotainment functions can be viewed in the dedicated menus:

- Connected devices (A);
- Player (B) visible only in ROAD mode (Info Mode) (;
- Telephone (C).

If Bluetooth is active, apart from the Bluetooth icon, also associated and/or connected device indication is displayed, such as:

- 1) Smartphone connected;
- 2) Rider helmet earphones connected;
- 3) Passenger helmet earphones connected;
- 4) Rider helmet earphones connected and passenger helmet earphones associated;
- 5) Passenger helmet earphones connected and rider helmet earphones associated;
- 6) Rider helmet and passenger helmet earphones connected;
- 7) Ducati GPS navigator connected.

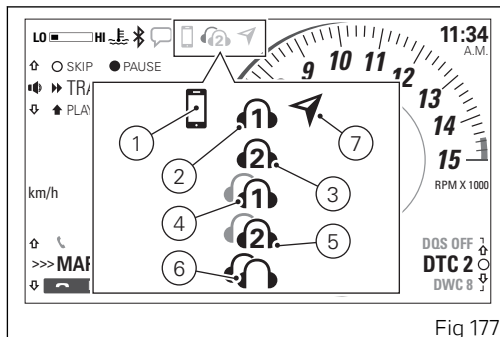

Fig 177

In general, for all the devices, if the icon is grey, the device is associated but not connected; if the icon is blue, the device is connected.

It is possible to connect up to a maximum of 4 devices.

## Phone

Use the PHONE function:

- to manage incoming calls by means of button (1), button (2) and button (4);
- to recall the last calling number within 5 seconds from call interruption (RECALL function);
- to recall any of the last 7 calling numbers from the list under CALLS function (page 103).

### Note

It is not possible to make a call by selecting the name/number from the contact list through the function buttons.

To answer the call, press button (1).

To reject the call, press button (2).

To end the call once accepted, press button (2).

If there is an incoming call while the Player is active, the latter is paused throughout the phone call and will resume operation when call is over.

During 5 seconds after hang-up, the rectangle corresponding to the Recall function is activated to allow the recall. After this 5 second time, the rectangle of the Recall function is disabled.

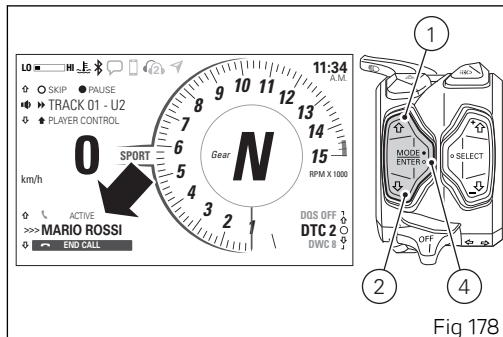

Fig 178

To activate the Recall function within the 5 seconds, press button (1).

### Note

If a call is in progress and the instrument panel shows the missed call symbol, current call view has higher priority over the missed call.

In case of missed calls from the moment the smartphone is connected to the bike to the moment it is disconnected, the missed call symbol will be displayed.

The number of missed calls is not displayed.

In case there is at least one SMS/MMS/EMAIL not read from the moment the smartphone is connected to the bike to the moment it is disconnected, the unread message symbol will be displayed.

The number of unread messages is not displayed.

Both symbols flash for 3 seconds and then stay steady on the instrument panel for 57 seconds.

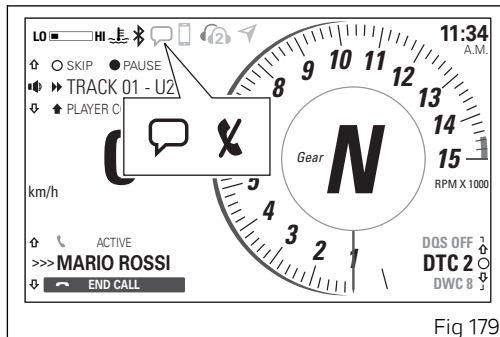

Fig 179

## Player

If one Smartphone is connected, the Function Menu will show the **PLAYER** function.

Use button (1) or (2) to scroll the Function Menu and view the **PLAYER** function in ROAD layout ( (Info Mode) only.

If Player is not active, the instrument panel displays "**PLAYER OFF**".

Press button (4) to switch it on. The instrument panel shows "**PLAYER ON**" and displays the Player menu above the speed value.

To deactivate the player menu display, keep button (2) pressed for 2 seconds.

If Player is active, the instrument panel displays "**PLAYER ON**".

To display the Player menu, keep button (1) pressed for 2 seconds.

To turn off the Player press button (4), the instrument panel will now display "**PLAYER OFF**".

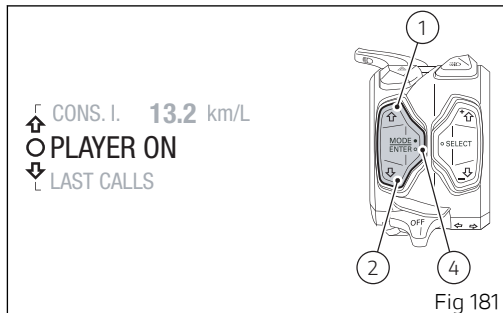
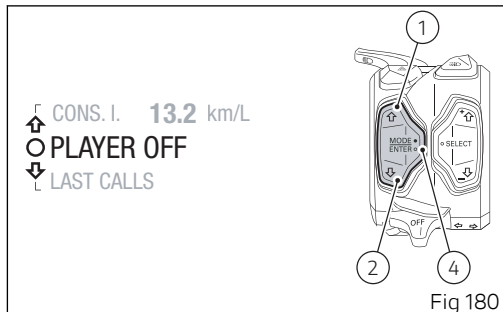

## Note

The Player function cannot be activated when a call is incoming, in progress or in recall. If the smartphone is disconnected, player is turned off.

When the Player is turned on, within Player control page (Fig 182), button (1), button (2) and button (4) can only be used to control the Player:

- Volume up: Press button (1) once.
- Volume down: Press button (2) once.
- Pause / Play: Press button (4) for 2 seconds.
- Skip / Next track: Press button (4) once. Each press corresponds to a track skipped.

Press button (2) for 2 seconds to quit Player menu while maintaining the Player ON. The instrument panel will display "PLAYER ON" in the Function Menu but will deactivate the Player menu (Fig 182). After quitting Player controls:

- Player and its volume can no longer be controlled via the instrument panel;
- button (1), button (2) and button (4) have the normal functions.

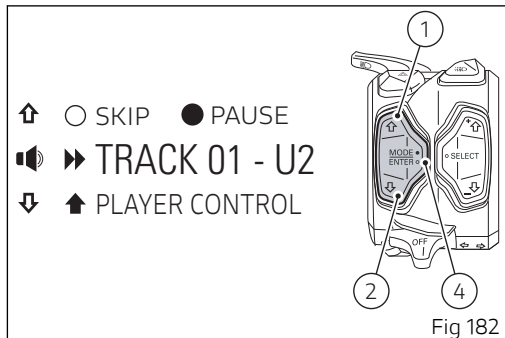

After quitting player menu press button (4) to turn Player off. The instrument panel shows "PLAYER OFF" (Fig 180).

## F.A.Q.

### **1) Why don't I receive any notification of received e-mails?**

E-mails are notified only if configured on the telephone source application. Check also that your phone supports the MAP profile.

If so, the DUCATI MULTIMEDIA SYSTEM, during the pairing phase, will send an access request to such profile which can be notified to the user explicitly (depending on the operating system) by requesting access authorisation to message notifications.

### **2) Why don't I receive any notification of received messages?**

Check that your phone supports the MAP profile. If so, the DUCATI MULTIMEDIA SYSTEM, during the pairing phase, will send an access request to such profile which can be notified to the user explicitly (depending on the operating system) by requesting access authorisation to message notifications.

### **3) Earphones do not connect. Why?**

If they have been already paired once, we recommend resetting the earphones and pair them again with the motorcycle (see earphones instruction manual).

### **4) When I receive a call, the instrument panel displays the caller number but not the name (despite being saved in the contact list).**

Check that the phone supports the PBAP profile. If so, the DUCATI MULTIMEDIA SYSTEM, during the pairing phase, will send an access request to such profile which can be notified to the user explicitly (depending on the operating system) by requesting access authorisation to the phone contact list.

### **5) By activating the Player through the instrument panel, music does not start.**

The activation depends on the phone settings. In this case, after activating the Player through the instrument panel, also start the music application on your Smartphone.

### **6) It happens that the music is played with continuous interruptions.**

If the devices have just been connected, it may be that the Bluetooth control unit is still completing the connection phase with the concerned devices. It is furthermore necessary to activate the PBAP and MAP profiles. Therefore, in case of iOS, please refer to point 7). In case of Android, please refer to points 2)4)

**7) I do not receive any message notification on my iPhone. Why?**

Select Bluetooth in the Setting Menu. In the list "My devices" select "i" next to "Ducati Media System". Flag "Show notifications".

## DRL automatic mode indication

This function indicates if the DRL light is set to "AUTO" or "MANUAL".

Through the setting menu it is possible to change the control mode of the DRL light, refer to the chapter "Setting menu - DRL light mode setting - (DRL)."

If the DRL light is set to "AUTO":

- with low beam on and DRL off, the indication (1, Fig 184) is shown;
- with low beam off and DRL on, the indication (2, Fig 184) is shown on a green background in "DAY" mode, or coloured in green in "NIGHT" mode.

If the DRL light is set to "MANUAL":

- with low beam on and DRL off, no indication is shown;
- with low beam off and DRL on, the indication (3, Fig 184) is shown on a green background in "DAY" mode, or coloured in green in "NIGHT" mode.

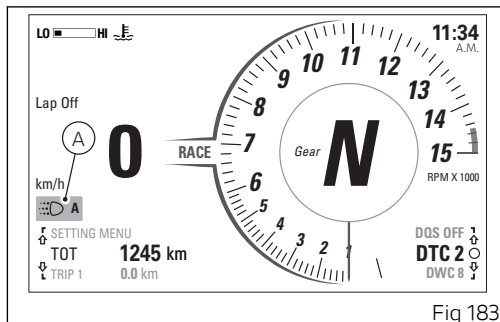

Fig 183

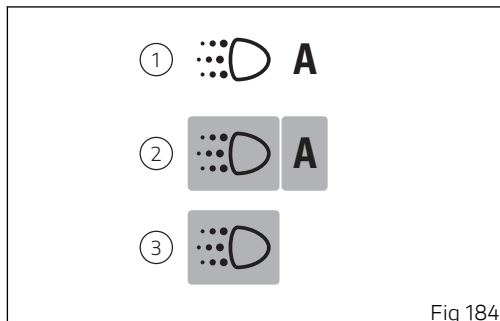
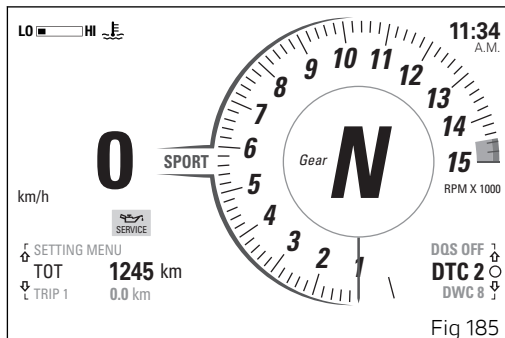

Fig 184

## OIL SERVICE zero warning

The first service warning is the OIL SERVICE zero and is triggered as soon as the odometer reaches the first 1,000 km (600 mi). Warning is displayed until "Reset" by the Ducati authorised service centre, during maintenance.



## OIL SERVICE or ANNUAL SERVICE or DESMO SERVICE indication

When the service threshold is reached, the warning for the type of service required is triggered:

- OIL SERVICE (A);
- ANNUAL SERVICE (B);
- DESMO SERVICE (C).

Required service warning is triggered and displayed in red until "Reset" by the Ducati authorised service centre, during maintenance.

It is possible to view in the Setting menu the deadlines for the SERVICE (Oil Service in Km or miles, Desmo Service in Km and Annual Service in year/month/day): see "Service thresholds display (Service Info)" page 182.

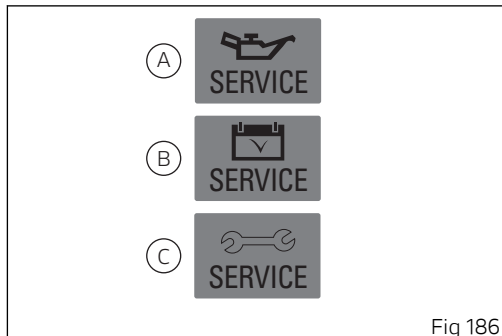

Fig 186

## OIL SERVICE or ANNUAL SERVICE or DESMO SERVICE countdown indication

After OIL SERVICE zero indication first reset (at 1,000 km - 600 mi), the instrument panel activates the following indications in yellow for 5 seconds upon Key-ON:

- The OIL SERVICE (A) indication with the count of the mileage in kilometres (miles) instead of the odometer (TOT), 1000 km (600 mi) earlier than the service threshold;
- The ANNUAL SERVICE (B) indication with the count of the days remaining to the due service, displayed instead of the odometer (TOT);
- The DESMO SERVICE (C) indication with the count of the mileage in kilometres (miles) instead of the odometer (TOT), 1000 km (600 mi) earlier than the service threshold;

It is possible to view in the Setting menu the deadlines for the SERVICE (Oil Service in Km or miles, Desmo Service in Km and Annual Service in year/month/day): see "Service thresholds display (Service Info)" page 182.

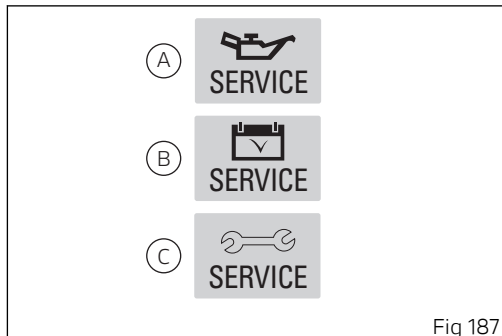

Fig 187

## Warnings/Alarms (WARNING)

The instrument panel manages a number of warnings / alarms, aimed at giving useful information to the rider during use.

Upon Key-On, if there are active warnings the instrument panel displays the indication of the present warnings.

During normal vehicle operation, when a warning is triggered the instrument panel automatically displays the warning. When a warning is triggered, the indication remains well visible for 3 seconds ("large" icon) then becomes smaller ("small" icon). If several live warnings are present, the corresponding icons will be displayed one after the other and every one will stay on for 3 seconds.

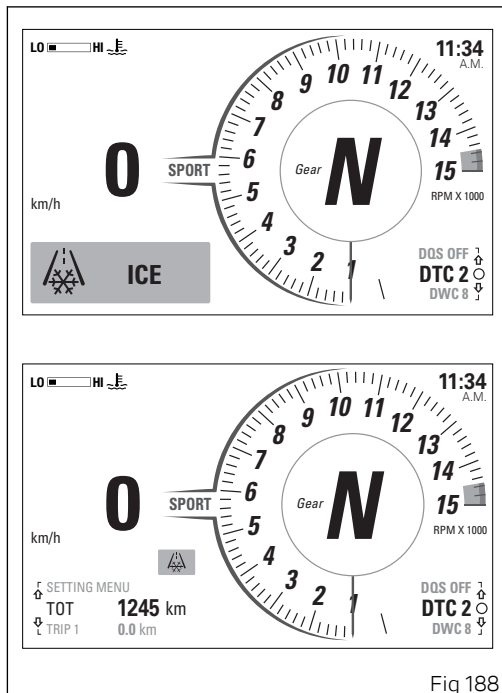

Fig 188

## Ice on the road indication (ICE)

This function warns the rider when there might be ice on the road, due to the low external temperature. This warning turns on when temperature drops to 4°C (39°F) and turns off when temperature rises to 6°C (43°F).



### Attention

This warning does not eliminate the possibility of icy road areas even with temperatures above 4°C (39°F); when ambient temperature is "low", ride responsibly, especially on road areas not exposed to sunlight and/or on bridges.

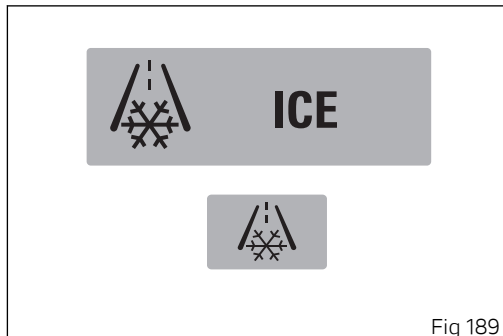

## Low battery indication (LOW Battery)

This function warns the user that the status of the vehicle battery is low.

Warning is activated when battery voltage is lower than/equal to 11.0 Volt.

### **Note**

In this case, Ducati recommends charging battery in the shortest delay using the special instrument as engine could not be started.

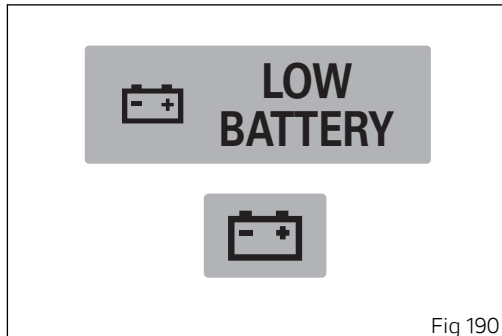

## Date setting

This function prompts the user to enter the date via the Setting Menu.



### Note

In this case Ducati recommends to stop and enter the calendar date using the function "Date setting (Date and Clock)".

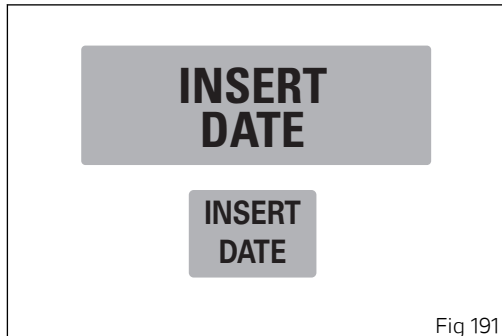

## ABS Front Only

When this warning is activated, it is necessary to ride carefully because the ABS setting in use only controls the front wheel braking.

This warning is activated whenever ABS level 1 is selected.



### Attention

In this case, Ducati recommends paying particular attention to the riding style and the braking mode.

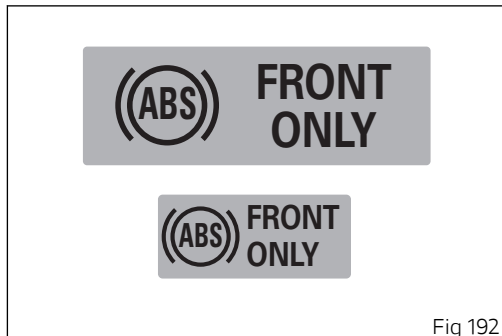

## Error indication

The instrument panel manages error warnings in order to allow the rider to identify any abnormal motorcycle behaviour in real time.

Upon vehicle Key-On, in case of active errors on the instrument panel, the MIL light (A) or the Generic Error light (B) will turn on.

During normal operation, when an error is triggered, the instrument panel turns on the MIL light (B) or the Generic Error light (A).

### Attention

When one or more errors are displayed, always contact a Ducati Dealer or authorised Service Centre.

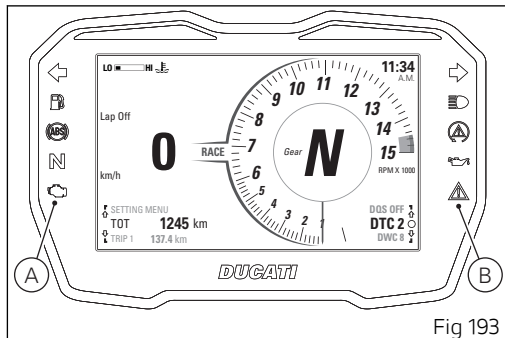

Fig 193

## Viewing side stand status

The instrument panel receives information on side stand status and if side stand is down/open, the icon "SIDE STAND" is displayed on a red background.

In case of side stand sensor fault, the instrument panel will display the stand down/up indication with MIL light turns on (warning light 9, see "Instrument panel").

If instrument panel does not receive side stand status, stand down/open "SIDE STAND" indication will flash to indicate an undefined status.

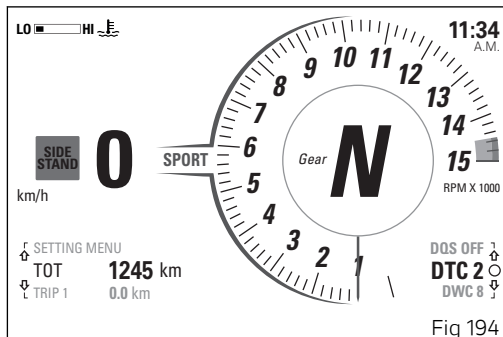

Fig 194

## Light control

### Low / High beam

At Key-On, the high beam and low beam lights are OFF: only the parking lights and the DRL light are turned on (DRL lights are not present in China, Canada and Japan versions).

After starting the engine the high beam is automatically turned on if the AUTO mode is set and the instrument panel detects poor ambient light (NIGHT): if, on the other hand, the instrument panel detects good light conditions (DAY), the DRL light remains on and the low beam remains off; it is possible to switch the DRL light to low beam (and vice versa) with button (9).

If the low beam is activated, it is possible to switch on the high beam by pressing button (3), positions (A) and (B). If engine is not started upon key-on, it is anyway possible to switch high/low beams on by pushing button (3) position (C) on LH switch.

If within 60 seconds from the "manual" switching on of the low / high beam the engine is not started, the lights are disabled again (off).

### Light switching-off during vehicle starting

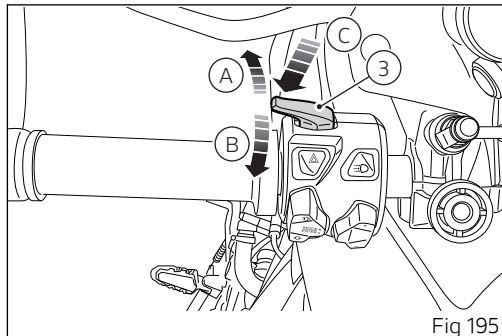

To preserve the motorcycle battery, if when starting the engine the high/low beams or the DRL lights are ON, the headlight is automatically switched off and then on again when the engine is started.

## DRL (Daytime Running Light)

Upon Key-On, the DRL lights are turned on (DRL lights are not present in China, Canada and Japan versions). It is possible to switch off the DRL lights by means of button (9) on the left-hand switch. By pressing button (9) again, the DRL lights are switched on again.

### Note

Every time button (9) is pressed, the DRL light automatically switches to MANUAL mode. To go back to the AUTO mode, turn the Key Off and On or set the AUTO mode by means of the DRL CONTROL function in the Setting Menu.

By pressing button (3), the high and low beams are turned on whereas the DRL light is turned off. Upon releasing the button (3), the DRL light is automatically switched on again.

### DRL in AUTO mode

If the DRL is in this mode, when starting the engine it automatically switches off and the low beam is activated if the instrument panel detects poor light conditions (NIGHT). If the instrument panel detects good light conditions (DAY), the DRL remains on and

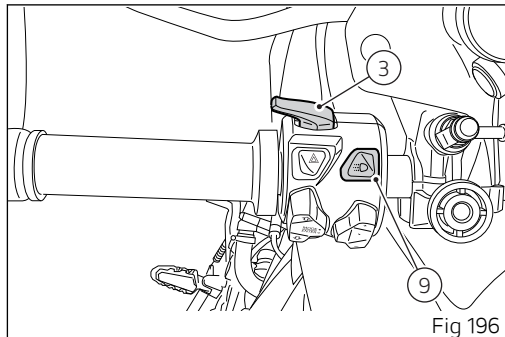

the low beam off: in this mode, the instrument panel automatically switches from the DRL light to the low beam and vice versa, according to the detected ambient light conditions. The display shows the green logo with letter A.

### Attention

Using the DRL light in AUTO (automatic) mode in case of poor light conditions, especially in case of fog or clouds, could impair safety: in this case DUCATI recommends to manually activate the low beam.

DRL in MANUAL mode

If the DRL light is in this mode, it does not change status when starting the engine. To switch on or off the DRL light it is necessary to press button (9). The display shows the yellow logo with letter M.



### **Attention**

Using the DRL light in poor light conditions (dark) could compromise the riding visibility and dazzle who is coming on the opposite lane.



### **Note**

Using the DRL light during the day improves visibility as it is easier to perceive by those coming on the opposite side compared with the low beam.

## Turn indicators

Turn indicators are automatically reset by the instrument panel.

To activate the left turn indicators, press button (10) in position (I); to activate the right turn indicators, press button (10) in position (L).

Turn indicators can be cancelled by pressing button (10) on LH switch.

### Automatic switch-off:

The turn indicators switch off automatically after the turn, as calculated based on vehicle speed, lean angle and in general according to the analysis of vehicle dynamic conditions.

This means that automatic switch-off is triggered when vehicle speed exceeds 20 km/h (12.4 mph) after the turn indicator button was pressed.

Turn indicators also switch off automatically if they remained on for a long mileage (which can range between 200 and 2000 metres (656-6562 feet), depending on vehicle speed when the turn indicator button was pressed).

If the turn indicator switch is again operated, while turn indicator is still on, automatic switch-off feature is re-initialised.

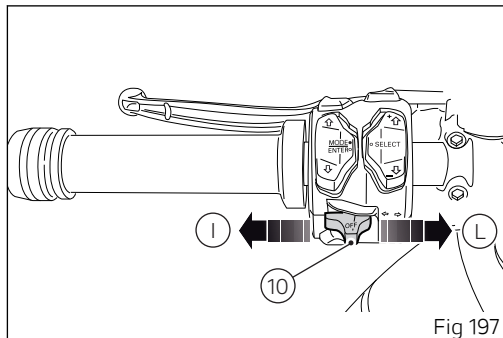

Fig 197

Automatic switch-off feature can be disabled through the specific option within the SETTING MENU. For further details, refer to paragraph Turn indicator automatic switch-off feature (TURN INDICATORS) page 204.



## Attention

The automatic deactivation systems are assist systems helping the rider control the turn indicators in the most comfortable and easy way. Such systems have been designed to work in most riding manoeuvres, nonetheless the rider must pay attention to the turn indicator operation (disabling or enabling them by hand if needed).

## Hazard function (4 turn indicators)

The "Hazard" function turns all four turn indicators on at the same time to signal an emergency condition. Push button (11) to activate the "Hazard" function. It can only be activated when vehicle is turned on (Key-ON). When the "Hazard" function is active, all four turn indicators blink at the same time as well as warning lights on the instrument panel. The "Hazard" function can be manually turned off exclusively when vehicle is on (Key-ON), by pressing button (11).

Once the "Hazard" function is activated, if vehicle is turned off (key turned to "OFF"), the function stays active for 2 hours. After 2 hours, the turn indicators switch OFF automatically in order to save battery charge.

### Note

If user performs a Key-ON while the "Hazard" function is still active, the function will remain ON (temporary turn indicator control interruption is allowed during the instrument panel initial check routine).

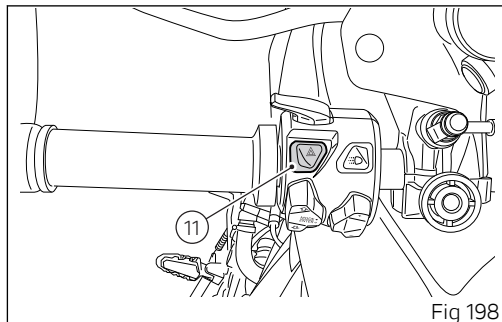

Fig 198

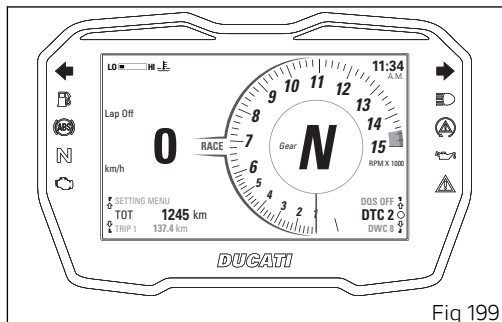

Fig 199

 **Note**

If there is a sudden interruption in the battery while the function is active, the instrument panel will disable the function when the voltage is restored.

 **Note**

The "Hazard" function has higher priority compared to normal operation of the single turn indicators, this means that, as long as it is active, it will not be possible to activate the single right or left turn indicators.

## **Immobilizer system**

To further improve the anti-theft protection, the motorcycle is equipped with an engine electronic block system (IMMOBILIZER) that is automatically activated every time the instrument panel is switched off.

Inside of each key handgrip there is an electronic device that modulates the signal sent by a special antenna integrated in the ignition switch upon starting.

Such modulated signal represents the "password", that changes upon every starting, that allows the control unit to acknowledge the key and thus starting the engine.

## Keys

The motorcycle comes with 2 keys.

They contain the "Immobilizer system code".

Keys (B) are those for the standard use, i.e. to:

- start the engine;
- open the fuel tank plug;
- open the seat lock.



### Attention

Separate the keys and use only one of the two to ride the bike.

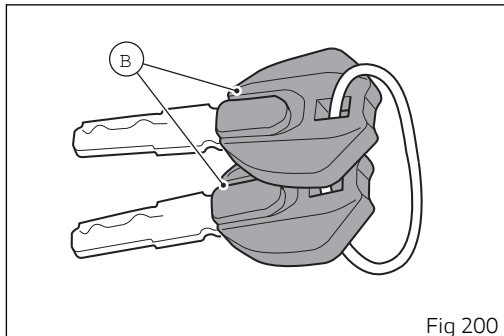

Fig 200

## Key duplication

When a customer needs spare keys, he/she shall contact a Ducati authorised service centre and bring all keys he/she still has.

The Ducati authorised service centre will program all new and old keys.

The Ducati authorised service centre may ask the customer to prove to be the motorcycle owner.

The codes of the keys missing during the programming procedure will be erased to ensure that any lost key can not start the engine.



### Note

If the motorcycle owner changes, it is necessary that the new owner is given all keys.

## Restoring motorcycle operation via the PIN CODE

In case of key acknowledgement system or key malfunction, the instrument panel allows the user to enter his/her own PIN code to temporarily restore motorcycle operation.

if the PIN CODE function is active, the instrument panel displays "Insert Pin" with four spaces allowing the rider to enter digits of the Pin code to be entered. "0" and "- - -".

Entering the code:

- 1) Each time you press the button (1) the displayed number increases by one (+ 1) up to "9" and then starts back from "0";
- 2) Each time you press the button (2) the displayed number decreases by one (- 1) up to "1" and then starts back from "0";
- 3) To confirm the number, press the button (4).

Repeat the procedures until you confirm all the 4 digits of the PIN CODE.

When you press button (4) to confirm the fourth and last digit:

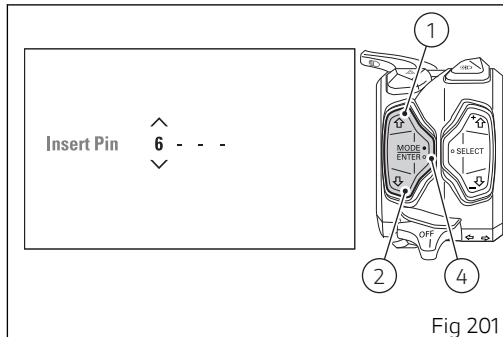

Fig 201

- if there is a problem during the PIN code check, the instrument panel displays "ERROR" for 2 seconds and then passes to the standard screen.
- if the PIN is not correct, the instrument panel displays WRONG for 2 seconds and then goes back to the "Insert Pin" indication with spaces to enter again the four digits of the Pin code.
- if the PIN CODE is correct, the instrument panel shows CORRECT for 2 seconds, and then displays the "standard screen".



## **Important**

If this procedure is necessary in order to start the motorcycle, contact an Authorised Ducati Service Centre as soon as possible to fix the problem.

# Controls

## Position of motorcycle controls



### Attention

This section shows the position and function of the controls used to ride the motorcycle. Be sure to read this information carefully before you use the controls.

- 1) Instrument panel.
- 2) Key-operated ignition switch and steering lock.
- 3) Left-hand switch.
- 4) Clutch lever.
- 5) Right-hand switch.
- 6) Throttle twistgrip.
- 7) Front brake lever.
- 8) Rear brake pedal.
- 9) Gear change pedal.

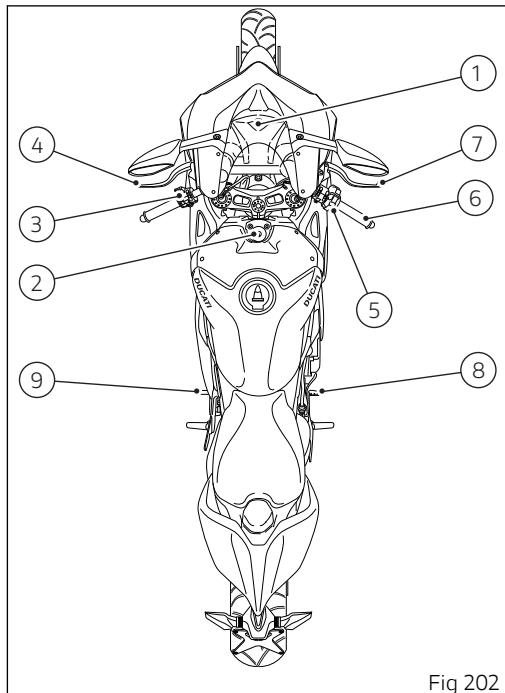

Fig 202

## Ignition switch and steering lock

It is located in front of the fuel tank and has three positions:

- A) ON: enables lights and engine operation;
- B) OFF: disables lights and engine operation;
- C) LOCK: the steering is locked;
- D) P: parking light and steering lock.

### Note

To move the key to the last position, press it down before turning it. The key can be removed in positions (B), (C) and (D).

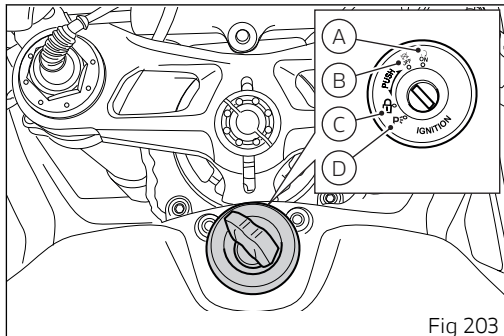





Fig 203

## Left-hand switch

- 1) Dip switch, two-position light selector switch:
  - pushed up (A): high beam ON (  ), back to its initial position (B): low beam ON (  );
  - (C) pushed down: high-beam flasher (  );
  - (FLASH), "Start-Stop lap" function.
- 2) 4 turn indicators (Hazard) on/off button.
- 3) DRL light on/off button.

The DRL lights are not present in China, Canada and Japan versions.

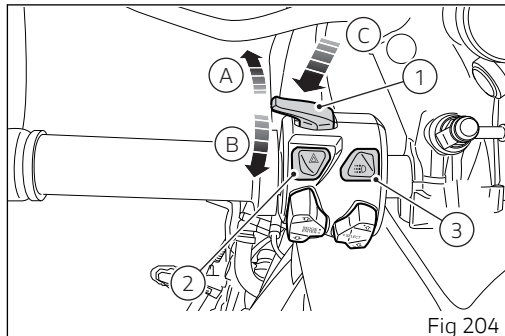





Fig 204

- 4) Menu navigation button.
- 5) Quick selection button.
- 6) 3-position turn indicator switch (  ):
  - centre position = OFF;
  - position (  ) = left turn;
- 7) Turn indicators cancel button.
- 8) Button (  ) = warning horn.

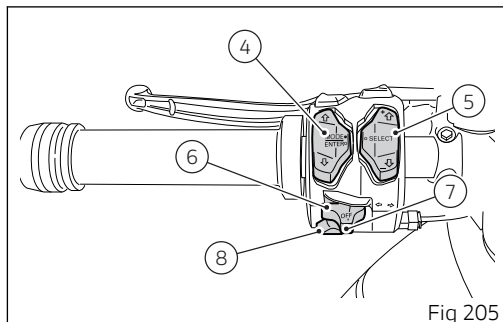

Fig 205

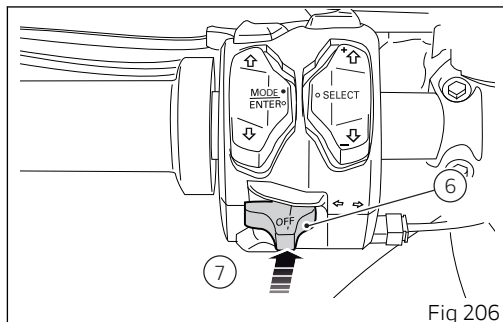

Fig 206

Button (4) for menu navigation features three positions:

- (D) for scrolling menu functions (UP);
- (E) for scrolling menu functions (DOWN);
- (F) for confirming menu functions.

Button (5) for quick selection features three positions:

- (G) quick selection confirmation;
- (H) quick selection button "UP" (UP+) to increase the level of the selected function;
- (I) quick selection button "DOWN" (DOWN-) to decrease the level of the selected function;

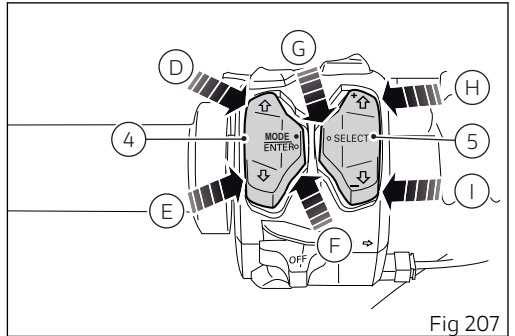

Fig 207

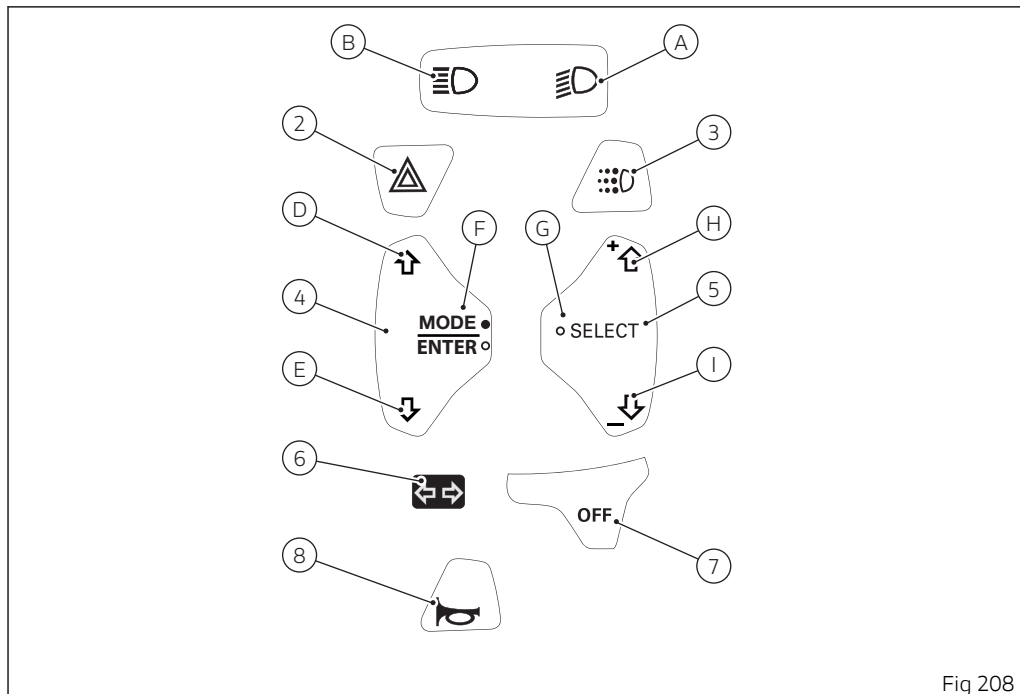

Fig 208

## Key

- A) Low beam.
- B) High beam.
- D) Menu UP
- E) Menu DOWN.
- F) Confirm display menu.
- G) Confirm quick selection.
- H) Quick selection UP.
- H) Quick selection DOWN.
- 2) Hazard.
- 3) DRL.
- 4) Menu navigation.
- 5) Quick selection.
- 6) Turn indicator.
- 7) Turn indicator off.
- 8) Horn.

## Clutch lever

Lever (1) disengages the clutch. It features a dial adjuster (2) for lever distance from the twistgrip on handlebar. The lever distance can be adjusted through 10 clicks of the dial (2). Turn clockwise to increase lever distance from the handgrip. Turn the adjuster counter clockwise to decrease lever distance. When the clutch lever (1) is operated, drive from the engine to the gearbox and the drive wheel is disengaged. Using the clutch properly is essential to smooth riding, especially when moving OFF.



### Attention

Set clutch lever when motorcycle is stopped.



### Important

Using the clutch properly will avoid damage to transmission parts and spare the engine.



### Note

The engine can be started with the side stand down and the gearbox in neutral. If starting with a gear engaged, pull in the clutch lever (in this case the side stand must be up).

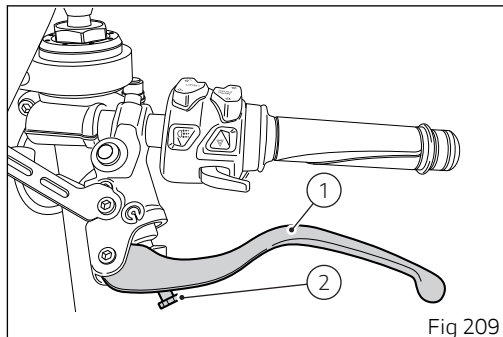

## Right-hand switch

- 1) Red ENGINE OFF switch.
- 2) ENGINE START button.
- 3) DPL button.

The switch (1) has two positions:

B) pushed down: KILL ENGINE.

A) pushed up: RUN ON. The engine can only be started in this position, pushing the button (2).

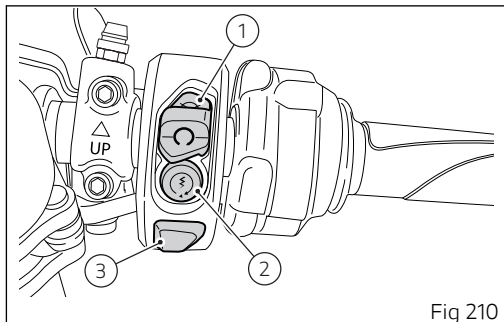

Fig 210

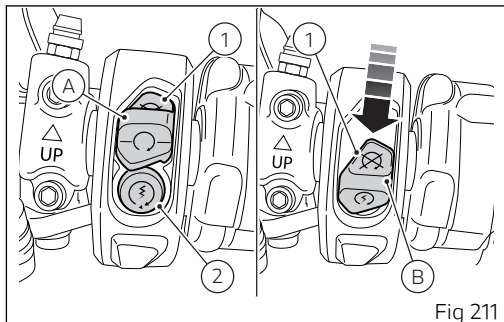

Fig 211

## Key

2) Engine starting.

3) DPL.

A) Run ON.

B) Run OFF.

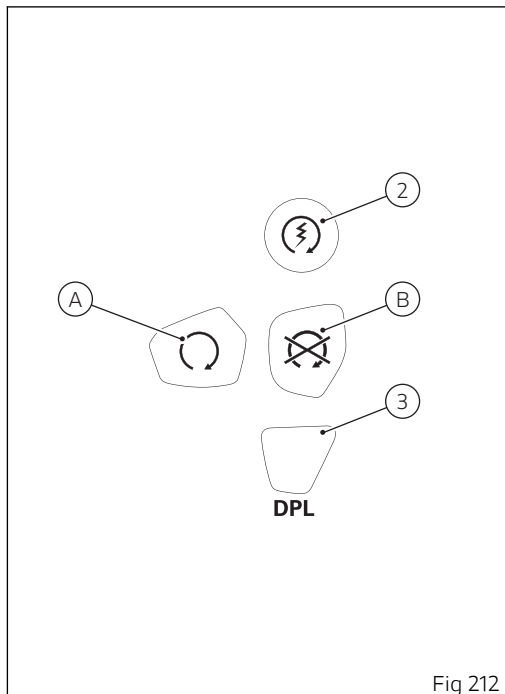
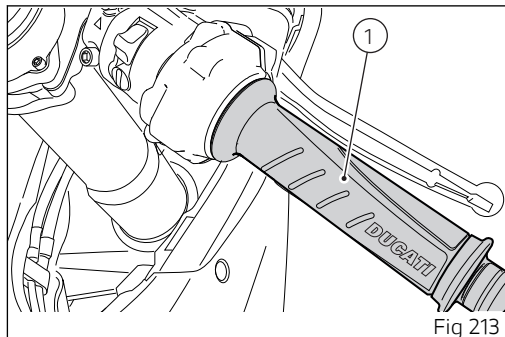

Fig 212

## Throttle twistgrip

The twistgrip (1) on the right handlebar opens the throttles.

When released, it will spring back to the initial position (idling speed).



## Front brake lever

Pull in the lever (1) towards the twistgrip to operate the front brake. The system is hydraulically operated and you just need to pull the lever gently.

The brake lever (1) has a dial (2) for adjusting the distance between lever and twistgrip on the handlebar.

The lever distance can be adjusted through 10 clicks of the dial (2). Turn clockwise to increase lever distance from the twistgrip. Turn the adjuster counter clockwise to decrease lever distance.

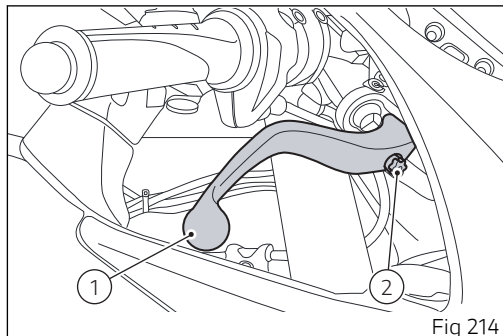

Fig 214

## Rear brake pedal

Press pedal (1) down with your foot to operate the rear brake.

The control system is of the hydraulic type.

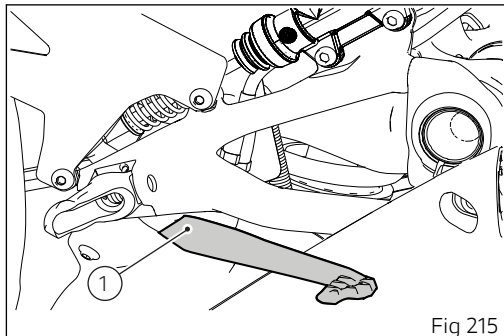

Fig 215

## Gear change pedal

When released, the gear change pedal (1) automatically returns to rest position N in the centre. This is indicated by the instrument panel N light coming on.

The pedal can be moved:

- down = press down the pedal to engage the 1<sup>st</sup> gear and to shift down. The N light on the instrument panel will go out;
- upwards= lift the pedal to engage 2<sup>nd</sup> gear and then 3<sup>rd</sup>, 4<sup>th</sup>, 5<sup>th</sup> and 6<sup>th</sup> gears.

Each time you move the pedal you will engage the next gear.

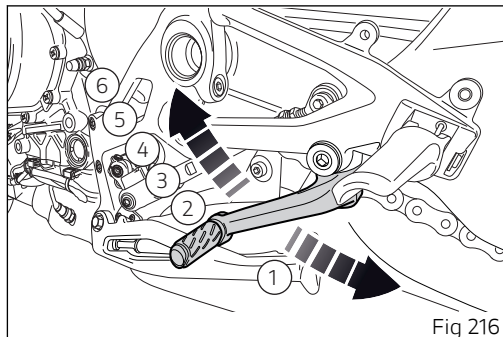

## Adjusting the position of the gearchange pedal and rear brake pedal

The position of the gearchange and rear brake pedals in relation to the footrests can be adjusted to suit the requirements of the rider.

Adjust the pedals as follows:

### Gear change pedal

The position of the gear change pedal in relation to the footrest can be adjusted to suit the requirements of the rider.

To correctly operate on the rod, remove the relevant side fairing.

### Attention

Have the gearchange rod adjusted at a Ducati Dealer or authorised Service Centre.

Hold linkage (1) using the special flat (A) and loosen nut (2).

Fit an open-end wrench to hexagonal element of linkage (1) and rotate until setting pedal in the desired position.

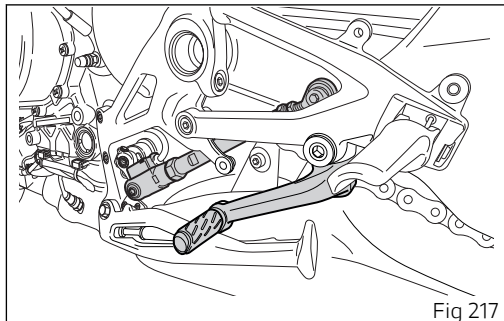

Fig 217

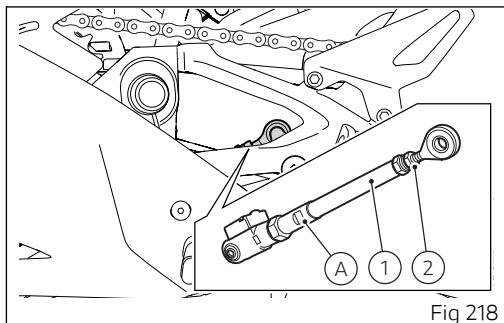

Fig 218

Tighten nut (2) onto linkage.

Once the adjustment is completed, check the correct value (B) of uniball travel (3).  
The uniball (3) travel value (B) must be between 0 mm (0 in) (uniball completely screwed in) and 6 mm (0.24 in).



### Attention

If the travel value does not respect the indicated parameters, repeat the adjustment operations as described before.

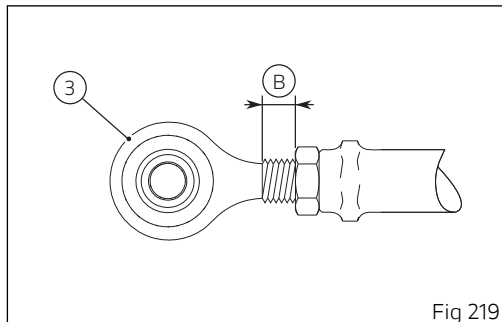

Fig 219

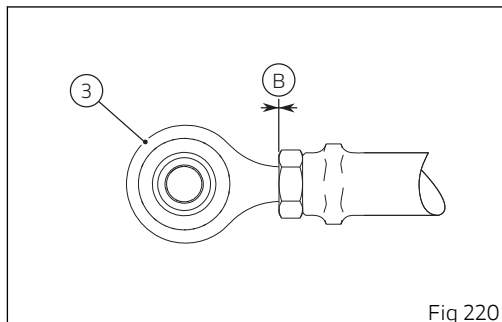

Fig 220

## Rear brake pedal

Loosen lock nut (7).

Turn pedal stroke adjusting screw (6) until pedal is in the desired position. Tighten the lock nut (7).

Operate the pedal (8) by hand to check that there is 1.5 to 2 mm (0.06÷0.09 in) of free play before the brake bites.

If not, adjust the length of the master cylinder pushrod.

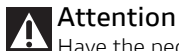

### Attention

Have the pedal adjusted at a Ducati Dealer or authorised Service Centre.

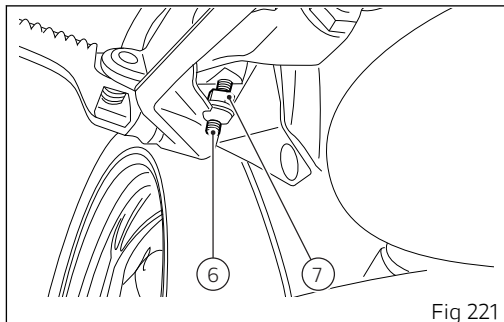

Fig 221

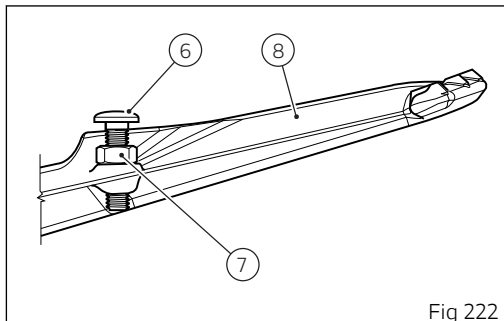

Fig 222

# Main components and devices

## Position on the vehicle

- 1) Tank filler plug.
- 2) Seat lock.
- 3) Side stand.
- 4) Rear-view mirrors.
- 5) Front fork adjusters.
- 6) Rear shock absorber adjusters.
- 7) Catalytic converter (both sides).
- 8) Exhaust silencer (both sides).

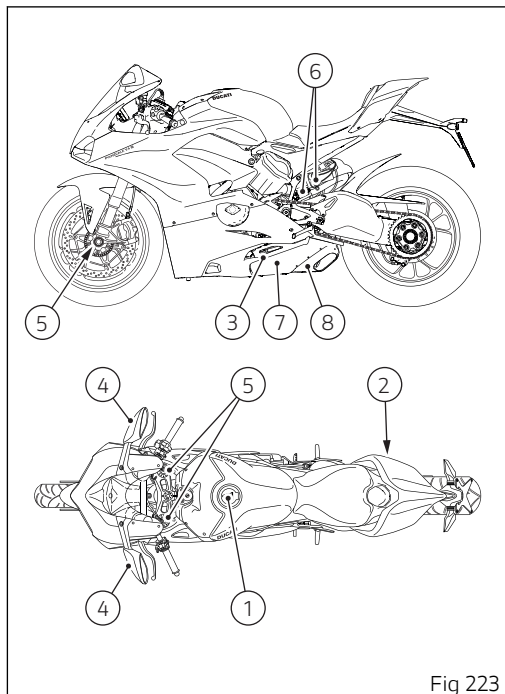

Fig 223

## Tank filler plug

### Opening

Lift flap (1) and insert the key in the lock. Turn the key clockwise by 1/4 of a turn to release the lock. Lift the plug (2).

### Closing

Close the plug (2) with the key inserted and push it down into its seat. Remove the key and close flap (1) protecting the lock.



### Note

Plug can only be closed when key is inserted.



### Attention

After refuelling, always make sure that the plug is perfectly in place and closed.

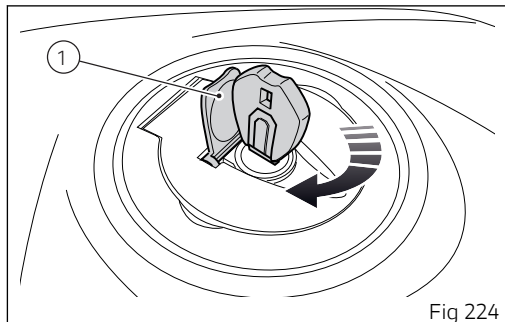

Fig 224

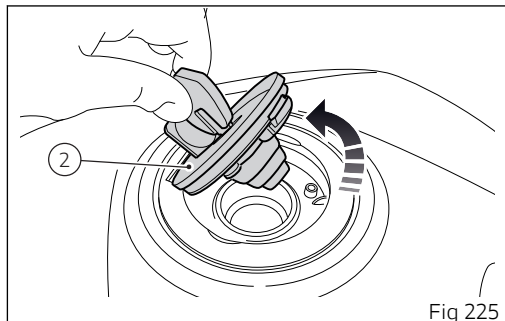

Fig 225

## Seat lock

### Opening

Insert the key into the seat lock (1) and turn it until the passenger seat (2) catch disengages with an audible click.

Pull the passenger seat (2) towards the front end of the motorcycle until releasing it.

### Closing

Insert the passenger seat (2) from the side and push it towards the rear end of the motorcycle until fully home.

### Attention

To close the seat cover insert it from the motorcycle side and slide it towards the rear side until hearing the engagement click.

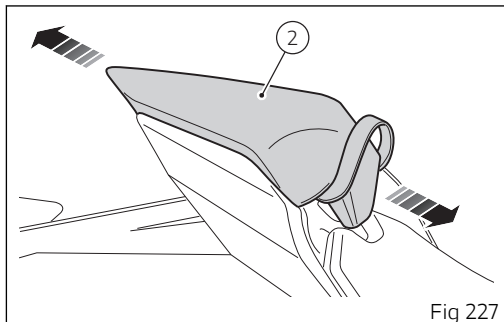
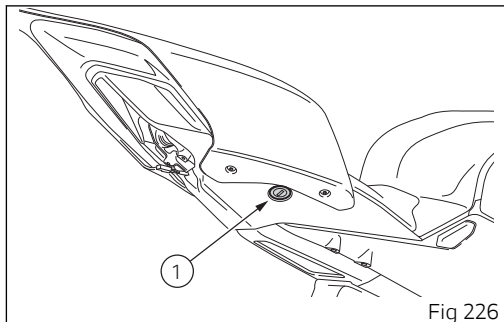

Before fitting the passenger seat (2), make sure that passenger strap (3) is correctly positioned.

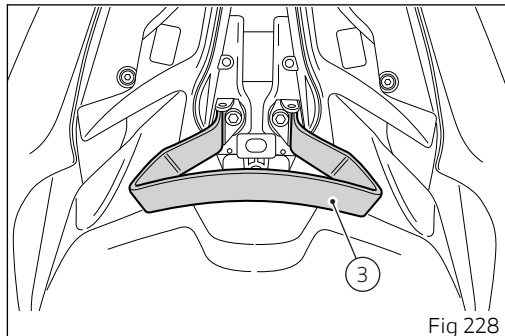

Fig 228

## Side stand

### Important

Place the motorcycle on the side stand only when you are not going to use it for short periods of time. Before lowering the side stand, make sure that the bearing surface is hard and flat.

Do not park on soft or pebbled ground or on asphalt melt by the sun heat and similar or the motorcycle may fall over. When parking in downhill road tracts, always park the motorcycle with its rear wheel facing downhill.

To pull down the side stand, hold the motorcycle handlebar with both hands and push down on the side stand (1) with your foot until it is fully extended. Tilt the motorcycle until the side stand is resting on the ground.

To easily find the side stand during the opening phase, press on pin (3) with your foot.

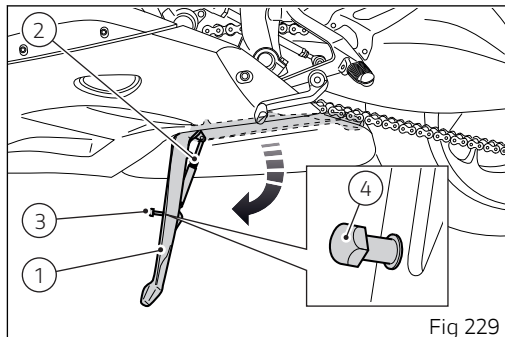

Fig 229

### Attention

When using the bike on the track, we recommend removing the pin (3) by working on the key (4).

To move the side stand to its rest position (horizontal position), lean the motorcycle to the right while lifting the thrust arm (1) with your foot.

To ensure trouble-free operation of the side stand joint, thoroughly clean it and then use SHELL Alvania R3 grease to lubricate all friction points.



### **Attention**

Do not sit on the motorcycle when it is supported on the side stand.



### **Note**

Check for proper operation of the stand mechanism (two springs, one into the other) and the safety sensor (2) at regular intervals.



### **Note**

The engine can be started with the side stand down and the gearbox in neutral. If starting with a gear engaged, pull in the clutch lever (in this case the side stand must be up).

## Bluetooth control unit

The motorcycle can be equipped with a Bluetooth control unit that works as a hub between the various supported electronic devices relying on a Bluetooth communication interface.

The Bluetooth control unit, which is not installed in this vehicle, can be purchased at a Ducati Dealer or Authorised Service Centre.



### Attention

Bluetooth Headset device manufacturers may incorporate certain changes within the standard protocols over the course of the lifecycle of the device (Smartphones and Earphones).



### Attention

These changes are outside the control of Ducati and may result in Bluetooth Headset devices functionality becoming impaired (sharing Music, multimedia player, etc.) and may equally affect some types of Smartphones (depending on supported Bluetooth profiles). This is why Ducati cannot guarantee multimedia player proper operation for:

- any earphones not coming with the "Ducati Kit part no. 981029498";
- any Smartphones not supporting the required Bluetooth profiles (even though paired to earphones coming with the "Ducati Kit part no. 981029498").



### Attention

In case of interference or noise due to particular conditions of the external environment, the Ducati earphone kit part no. 981029498 also allows sharing the music being played directly from rider helmet to passenger helmet (for further details please refer to the manual of the earphones coming with the Ducati kit part no. 981029498).

## **Note**

The Ducati kit part no. 981029498 can be purchased separately at a Ducati Dealer or Authorised Service Centre.

Check that your Smartphone supports the following profiles:

- MAP profile: for a correct display of SMS and MMS notifications;
- PBAP profile: for a correct display of the Smartphone contact list.

## **Attention**

Ducati does not ensure a correct connection to the Ducati Multimedia System of Bluetooth navigators that are not provided in the following kits:

- Kit of Ducati Zumo satellite navigator 350
- Kit of Ducati Zumo satellite navigator 390
- Kit of Ducati Zumo satellite navigator 395

## **Note**

The Ducati kits mentioned above can be purchased separately at a Ducati Dealer or Authorised Service Centre.

## Steering damper

The steering damper (1) is located before the handlebar and is secured to the steering head. It provides stable and accurate steering, improving the motorcycle's handling response under any conditions.

The damper is adjusted by electric impulses sent by the instrument panel to the adjuster inside damper body.

There are usually only two events requiring adjustment of the damping level selected by the rider, i.e.:

- High-frequency wobbling: the motorcycle steering will undergo fast movements due to an impulse (e.g., when landing after a wheelie).
  - increase steering damping power, so decrease the number of clicks of the steering damper.
- Low-frequency weaving: the motorcycle will tend to move to the side in a winding manner and in general will considerably slide (e.g., during a high-speed acceleration).
  - Decrease steering damping power, so increase the number of clicks of the steering damper.

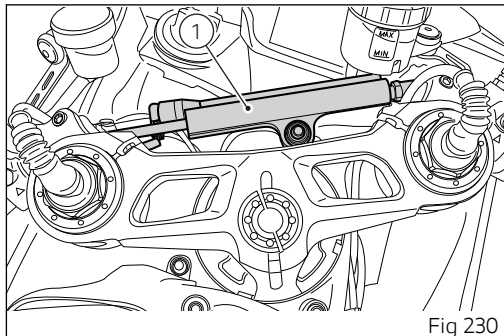

Fig 230

## Front fork adjustment

The motorcycle fork is completely adjustable. Fork rebound and compression damping is adjusted by electric impulses sent by the instrument panel to the adjusters inside the fork legs.



### Attention

Have the spring preload adjusted at a Ducati Dealer or authorised Service Centre.

For fork adjustment, follow the description on page 0 .

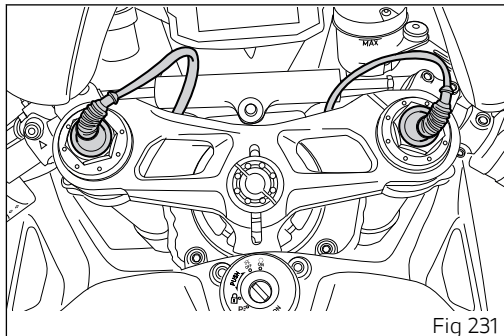

## Adjusting the rear shock absorber

The rear shock absorber has adjusters that enable you to suit the setting to the load on the motorcycle.

### Attention

The shock absorber is filled with gas under pressure and may cause severe damage if taken apart by unskilled persons.

When carrying a passenger and luggage, set the rear shock absorber spring to proper preload to improve motorcycle handling and keep safe clearance from the ground (work ring nuts to set spring preload). You may find that rebound damping needs adjusting as well.

The shock absorber is adjusted by electric impulses sent by the instrument panel to the adjusters inside the shock absorber body.

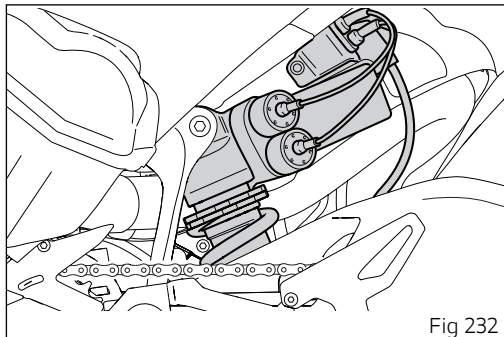

Fig 232

For shock absorber adjustment, follow the description on page 133.

# Riding the motorcycle

## Running-in recommendations

Maximum rotation speed

Rotation speed for running-in period and during standard use (rpm):

- 1) Up to 1,000 km (621 mi);
- 2) From 1000 km (621 mi) to 2500 km (1553 mi).

Up to 1,000 Km (621 mi)

During the first 1000 km (621.37 mi), keep an eye on the rev counter. It should never exceed: 5,500± (included) 6,000 rpm.

During the first hours of riding, it is advisable to run the engine at varying load and rpm, though still within recommended limit.

Strict observance of running-in recommendations will ensure longer engine life and reduce the likelihood of overhauls and tune-ups.



## Important

During the first 1000 km (621 mi) (Running-in period), i.e. when the Odometer displays a value  $\leq$  (lower than or equal to) 1000 km (621 mi), the pre-warning area, indicated in orange (Orange area), both for the bargraph filling and the display of the relevant number, is displayed when reaching 6000 rpm. During the running-in period we recommend not to exceed 6000 rpm, thus the instrument panel will not display the bargraph "Orange area".

To this end, roads with plenty of bends and even slightly hilly areas are ideal for a most efficient running-in of engine, brakes and suspensions. For the first 100 km (62 mi) use the brakes gently. Avoid sudden or prolonged braking. This will allow the friction material on the brake pads to bed in against the brake discs. For all mechanical parts of the motorcycle to adapt to one another and above all not to adversely affect the life of basic engine parts, it is advisable to avoid harsh accelerations and not to run the engine at high rpm for too long, especially uphill. Furthermore, the drive chain should be inspected frequently. Lubricate as required.

From 1000 to 2500 km (from 621 to 1553 mi)

At this point, you can squeeze some more power out of your engine. However never exceed 7,000 rpm.



### **Important**

During the whole running-in period, the maintenance and service rules recommended in the Warranty Card should be observed carefully. Failure to follow these instructions releases Ducati Motor Holding S.p.A. from any liability whatsoever for any engine damage or shorter engine life.

Strict observance of running-in recommendations will ensure longer engine life and reduce the likelihood of overhauls and tune-ups.

## Pre-ride checks



### Attention

Failure to carry out these checks before riding, may lead to motorcycle damage and injury to rider.

Before riding, perform a thorough check-up on your motorcycle as follows:

- **FUEL LEVEL IN THE TANK**  
Check the fuel level in the tank. Refuel if necessary (see "Refuelling").
- **ENGINE OIL LEVEL**  
Check the level in the sump through the sight glass; top-up if necessary (see "Checking the engine oil level").
- **BRAKE AND CLUTCH FLUID**  
Check liquid level in the corresponding reservoirs (see "Checking brake and clutch fluid level").
- **COOLANT**  
Check the level of coolant in the expansion reservoir; top up if necessary (see "Checking and topping up the coolant level").

- **TYRE CONDITION**

Check tyre pressure and condition (see "Tubeless tyres").

- **CONTROLS**

Work the brake, clutch, throttle and gear change controls (levers, pedals and twistgrip) and check for proper operation.

- **LIGHTS AND INDICATORS**

Make sure lights, indicators and horn work properly. Replace any burnt-out bulbs (see "Replacing headlight light bulbs").

- **KEY LOCKS**

Check the tightening of the filler plug (see "Filler plug").

- **STAND**

Make sure side stand operates smoothly and is in the correct position (see "Side stand").



### Attention

In case of malfunction, do not ride the motorcycle and contact a Ducati Dealer or authorised Service Centre.

To ensure trouble-free operation, the engine coolant pump requires a breather. This means that it is possible that a very small quantity of coolant oozes

out of the breather hole positioned in the upper part of the crankcase, and this will not affect proper operation of the engine or the cooling system.

## ABS light

After Key-ON, the ABS light (9) stays ON.

When the motorcycle speed exceeds 5 km/h, the warning light switches OFF to indicate the correct operation of the ABS system.



### **Attention**

In case of malfunction, do not ride the motorcycle and contact a Ducati Dealer or authorised Service Centre.

## ABS device

Check that the front (1) and rear (2) phonic wheels are clean.

### Attention

Clogged reading slots would compromise system proper operation. It is recommended to disable ABS system in case of muddy road surface because under this condition the system might be subject to sudden failure.

### Attention

Prolonged wheelies could deactivate the ABS system.

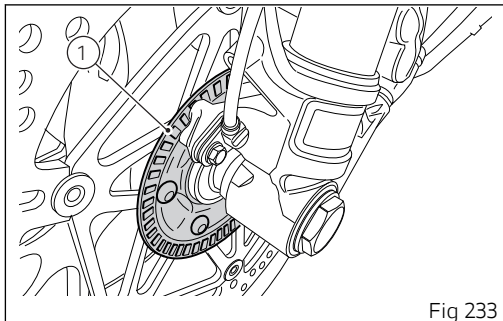

Fig 233

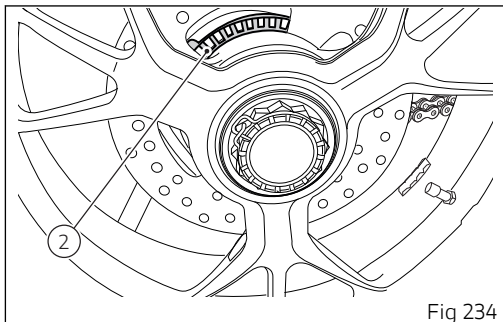

Fig 234

## Engine start

### Attention

Before starting the engine, become familiar with the controls you will need to use when riding.

### Attention

Never start or run the engine indoors. Exhaust gases are poisonous and may lead to loss of consciousness or even death within a short time.

Move the ignition key to ON. Make sure both the green light N (3) and the red light  (4) on the instrument panel come on.

### Important

The oil pressure light should go out a few seconds after the engine has started.

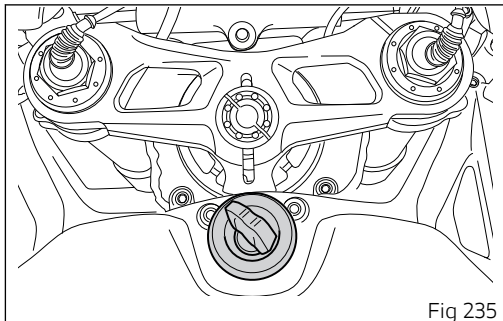

Fig 235

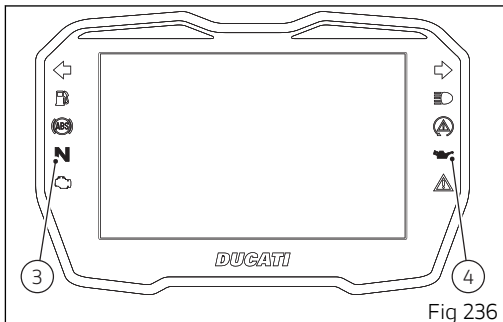

Fig 236

### Attention

The side stand must be fully up (in a horizontal position) as its safety sensor prevents engine starting when down.

### Note

It is possible to start the engine with side stand down and the gearbox in neutral. When starting the motorcycle with a gear engaged, pull the clutch lever (in this case the side stand must be up).

Move the red switch (1), on the right side of the handlebar upwards, and press button (2).

Let the motorcycle start without operating the throttle control.  
The red oil pressure warning light (4, Fig 236) should go out a few seconds after the engine has started.

### Note

If the battery is flat, system automatically inhibits starter motor cranking operation.

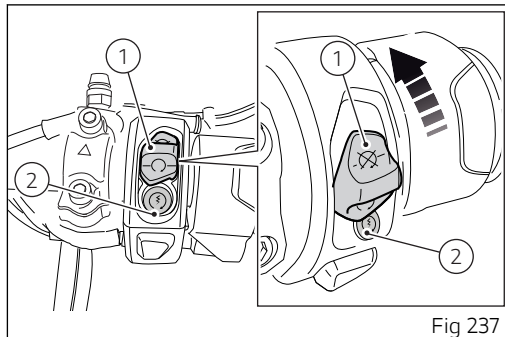
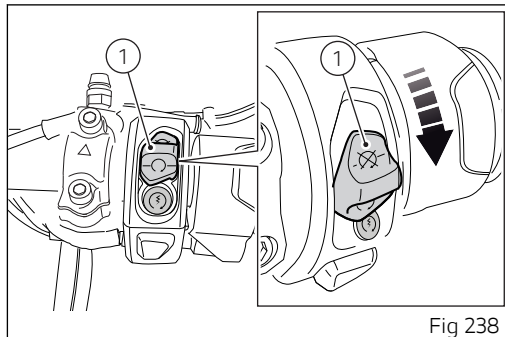

Fig 237

### Important

Do not rev up the engine when it is cold. Allow some time for oil to be heated and reach all points that need lubricating.

The engine will shut off by moving the red button (1) on the handlebar downwards to RUN OFF.



## Moving off

- 1) Squeeze the control lever to disengage the clutch.
- 2) Push down on gear change lever sharply with the tip of your foot to engage the first gear.
- 3) Speed up the engine by turning the throttle twistgrip while gradually releasing the clutch lever; the motorcycle will start moving off.
- 4) Let go of clutch lever and speed up.
- 5) To shift up, close the throttle to slow down engine, disengage the clutch, lift the gear change lever and let go of clutch lever. To shift down, proceed as follows: release the twistgrip, pull the clutch lever, shortly speed up to help gears synchronise, shift down (engage next lower gear) and release the clutch.

The controls should be used correctly and timely: when riding uphill do not hesitate to shift down as soon as the motorcycle tends to slow down, so you will avoid stressing the engine and the motorcycle abnormally.



### Attention

Avoid harsh acceleration, as this may lead to misfiring and transmission snatching. The clutch lever should not be held in longer than necessary after a gear is engaged, otherwise friction parts may overheat and wear out.



### Attention

Prolonged wheelies could deactivate the ABS system.

## Braking

Slow down in time, shift down to use engine brake and then brake by operating both front and rear brakes. Pull the clutch before the motorcycle stops to avoid engine from suddenly stalling.

## Anti-Lock Braking System (ABS)

Using the brakes correctly under adverse conditions is the hardest – and yet the most critical – skill to master for a rider. Braking is one of the most difficult and dangerous moments when riding a two wheeled motorcycle: the possibility of falling or having an accident during this difficult moment is statistically higher than any other moment. A locked front wheel leads to loss of traction and stability, resulting in loss of control.

The Anti-Lock Brake System (ABS) has been developed to enable riders to use the motorcycle braking force to the fullest possible amount in emergency braking or under poor pavement or adverse weather conditions.

ABS uses hydraulics and electronics to limit pressure in the brake circuit when a special sensor mounted to the wheel informs the electronic control unit that the wheel is about to lock up.

This avoids wheel lockup and preserves traction.

Pressure is raised back up immediately and the control unit keeps controlling the brake until the risk of a lockup disappears. Normally, the rider will perceive ABS operation as a harder feel or a pulsation of the brake lever and pedal.

The front and rear brakes use separate control systems, meaning that they operate independently. Likewise, the ABS is not an integral braking system and does not control both the front and rear brake at the same time.

## **Stopping the motorcycle**

Reduce speed, shift down and release the throttle twistgrip. Shift down to engage first gear and then neutral.

Apply the brakes and bring the motorcycle to a complete stop.

To switch the engine off, simply turn the key to OFF (page 250).

## Parking

Stop the motorcycle, then put it on the side stand. To prevent theft, turn the handlebar fully left and turn the ignition key to the LOCK position.

If you park in a garage or other indoor area, make sure that there is proper ventilation and that the motorcycle is not near a source of heat.

## Important

Never leave the ignition key in the switch when you are leaving your motorcycle unattended.

## Attention

The exhaust system might be hot, even after engine is switched OFF; pay particular attention not to touch the exhaust system with any body part and do not park the motorcycle next to inflammable material (wood, leaves etc.).

## Attention

Using padlocks or other locks designed to prevent motorcycle motion, such as brake disc locks, rear sprocket locks, and so on is dangerous and may impair motorcycle operation and affect the safety of rider.

## Refuelling

Never overfill the tank when refuelling. Fuel should never be touching the rim of filler recess.

### Warning

The fuel pressure inside the tank may, in extreme cases, cause fuel to "spray" when opening the fuel cap.

Always open the fuel cap slowly and carefully during the refill.

If you hear an audible hiss from the cap while opening it, wait until the stop of the hissing before opening it completely.

The sound is residual pressure escaping from the fuel tank, therefore the stop of the hiss indicates that there is no more residual pressure.

The situation described above is more likely in hot weather conditions.

### Attention

Use fuel with low lead content and an original octane number of at least 95.

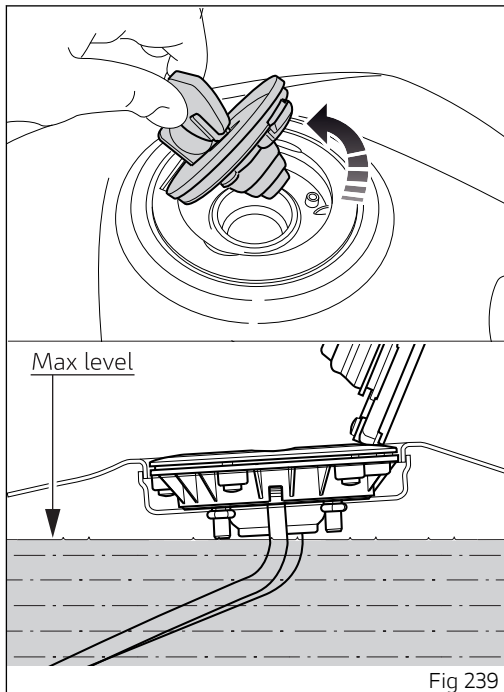

Fig 239



## Attention

The motorcycle is only compatible with fuel having a maximum content of ethanol of 10% (E10). Using fuel with ethanol content over 10% is forbidden. Using it could result in severe damage of the engine and motorcycle components. Using fuel with ethanol content over 10% will make the warranty null and void.

## Fuel label

The label identifies the fuel recommended for this vehicle.

1) The E5 reference inside the label indicates the use of fuel with a maximum oxygen content of 2.7% by weight and a maximum ethanol content of 5% by volume, according to EN 228.

2) The E10 reference inside the label indicates the use of fuel with a maximum oxygen content of 3.7% by weight and a maximum ethanol content of 10% by volume, according to EN 228.

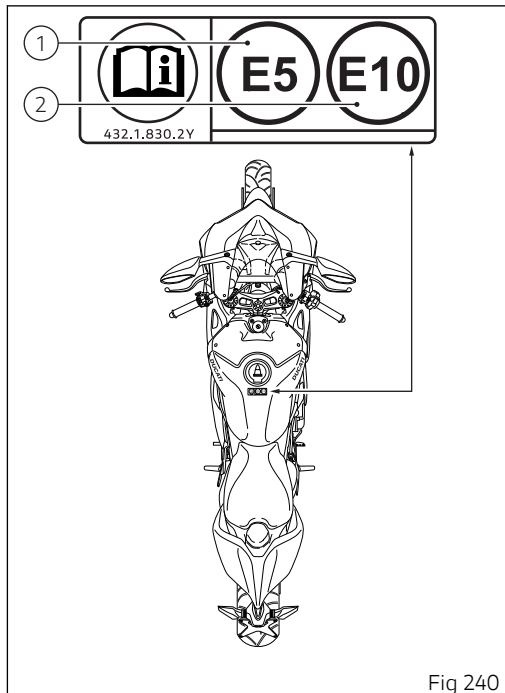

Fig 240

## Tool kit and accessories

The glove compartment positioned under the passenger seat contains a 4 mm (0.16 in) L-shaped Allen wrench (1).

To access the compartment, remove the passenger seat (page 269) and slide out the back (A) from the front.

Have the following parts (supplied as standard) installed by a Ducati Dealer or authorised Service Centre:

- passenger seat;
- right and left rear footpegs.

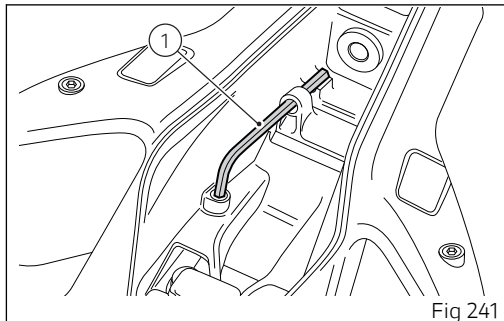

Fig 241

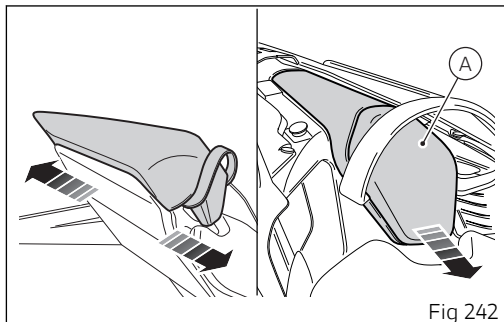

Fig 242

# Main use and maintenance operations



## Important

Have the fairing removal performed at a Ducati Dealer or Authorised Service Centre.

## Removing the fairing

To carry out some maintenance or repair operations, some motorcycle fairings must be removed.



### Attention

Failed or incorrect refitting of one of the removed components could cause its sudden detachment while riding resulting in loss of control of the motorcycle.



### Important

At every reassembly, to avoid damaging the painted areas and the Plexiglass windscreen, always place the nylon washers at the retaining screws.

## Change air filter



### **Important**

Have the air filter maintenance performed at a Ducati Dealer or Authorised Service Centre.

## Checking coolant level and topping up, if necessary

Check coolant level in the expansion reservoir, on the right side of the vehicle, through the inner sight slot, gaining access from the front wheel housing.

Check that the level is between the MIN (1) and MAX (2) marks on the side of the expansion reservoir.

Top up if the level is below the MIN mark.

### Attention

Place the motorcycle upright on a flat surface and make sure the engine is cold before proceeding.

### Important

Have the top-up performed at a Ducati Dealer or Authorised Service Centre.

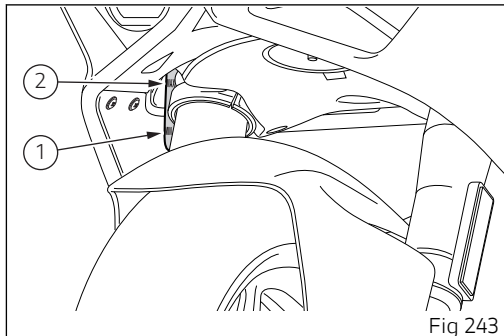

## Checking brake and clutch fluid level

The levels should not fall below the MIN marks on the respective reservoirs.

If level drops below the limit, air might get into the circuit and affect the operation of the system involved.

Fluid must be topped up and changed at the intervals specified in the scheduled maintenance table reported in the Warranty Booklet; please contact a Ducati Dealer or authorised Service Centre.

### Brake system

If you find exceeding clearance on brake lever or pedal and brake pads are still in good condition, contact your Ducati Dealer or authorised Service Centre to have the system inspected and any air drained out of the circuit.

### Attention

Brake and clutch fluid can damage paintwork and plastic parts, so avoid contact. Hydraulic fluid is corrosive; it may cause damage and lead to severe injuries. Never mix fluids of different qualities. Check seals for proper sealing.

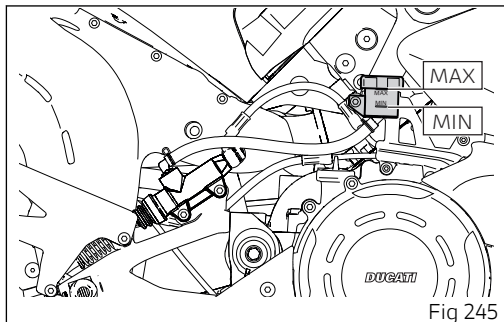
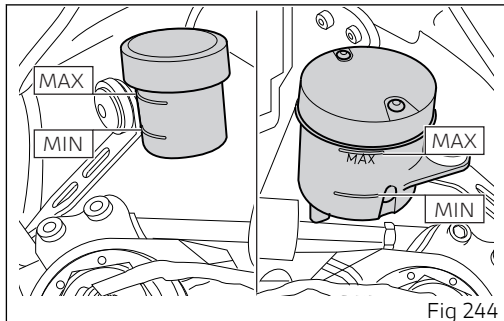

## Clutch system

If the control lever has exceeding clearance and the transmission snatches or jams as you try to engage a gear, it means that there might be air in the circuit. Contact your Ducati Dealer or authorised Service Centre to have the system inspected and air drained out.



### **Attention**

Clutch fluid level will increase as clutch plate friction material wears down. Do not exceed the specified level (3 mm (0.12 in) above the minimum level).

## Checking brake pads for wear

Check brake pads wear through the inspection hole in the callipers. Change both pads if friction material thickness of even just one pad is about 1 mm (0.04 in).



### Attention

Friction material wear beyond this limit would lead to metal support contact with the brake disc thus compromising braking efficiency, disc integrity and rider safety.



### Important

Have the brake pads replaced at a Ducati Dealer or authorised Service Centre.

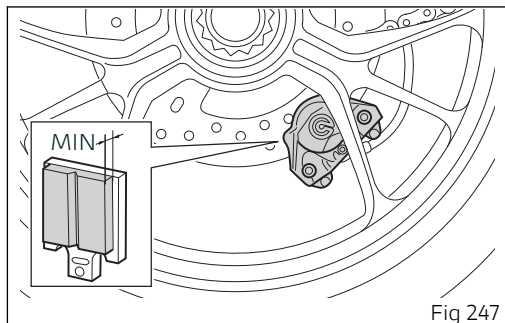
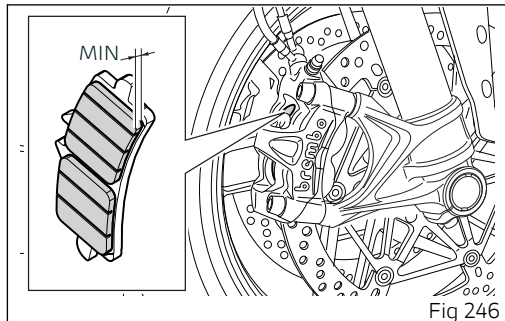

## Charging the battery

### PREPARATION

We recommend recharging the lithium battery by connecting the suitable battery charger directly to the positive and negative terminals of the battery using the cable with clips.

To do this, the following steps must be performed in sequence.

Loosen the four screws (1), collect the relevant washers and remove tank cover (2).

Loosen the two side (3) and upper (5) screws retaining the ignition switch cover (4).

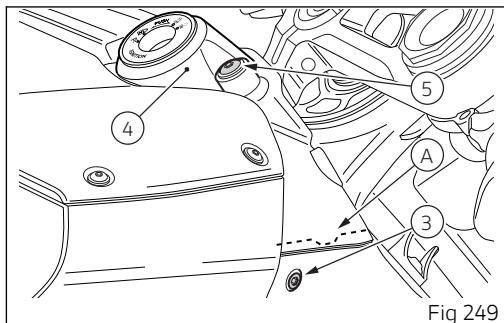
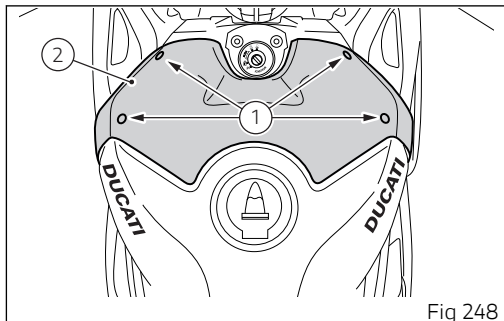

Slide out the ignition switch cover (4) from the rear and from upwards, paying attention to the inner tabs (A) connected to the side fairing, positioned on both sides.

Loosen screw (6) and slide out cover (7) retaining the battery.

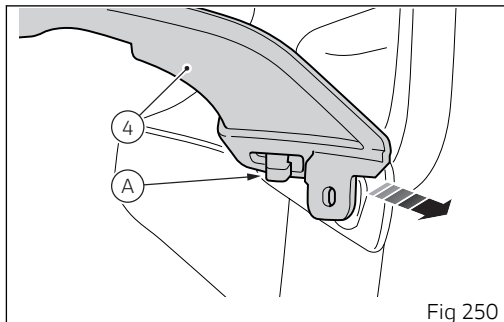

Fig 250

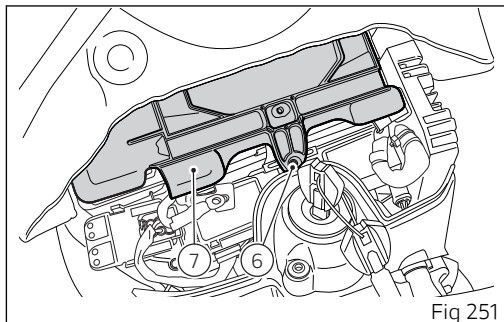

Fig 251

## CONNECTING THE BATTERY TO THE CHARGER

With the battery charger (A) disconnected from the power supply, firmly connect the red clip (8a) to the positive terminal (8).

Connect the black clip (9a) firmly to the negative terminal (9).

Connect the plug of the battery charger (A) to the wall outlet.

### Attention

Keep the battery out of the reach of children.

Charge battery using the special Ducati-approved battery charger (A) for lithium batteries, only. Do not use battery chargers for lead batteries or any other type of battery maintainer/charger. Charge the battery ensuring the vehicle is in a room with a temperature below 40° C (104° F).

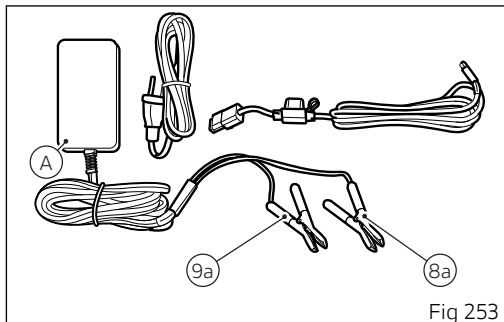
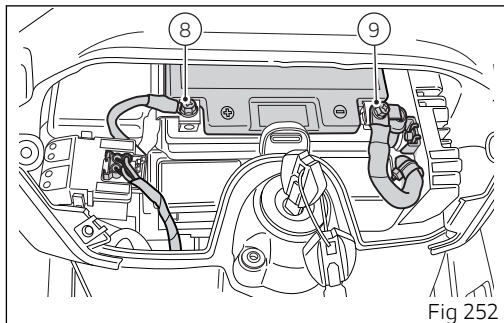

## DISCONNECTING THE BATTERY FROM THE CHARGER

Once the charging process is complete, disconnect the battery charger (A) by carrying out the connection operations in reverse order.

Disconnect the plug of the battery charger (A) from the wall outlet.

Disconnect the black clip (9a) from the negative terminal (9) and the red clip (8a) from the positive terminal (8).

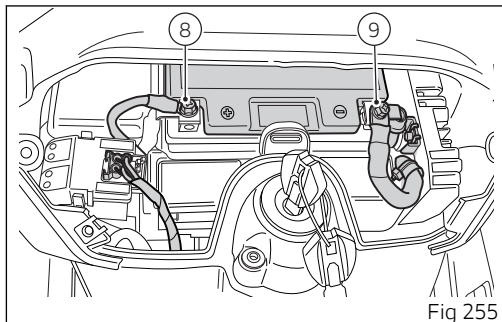
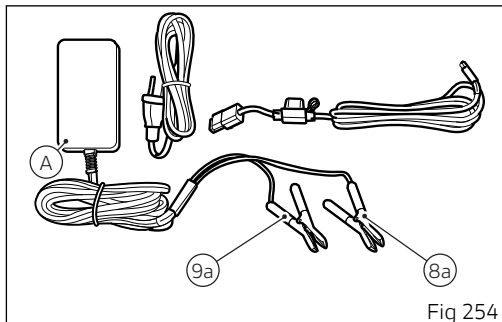

Position the cover (7) fastening the battery and tighten the screw (6).

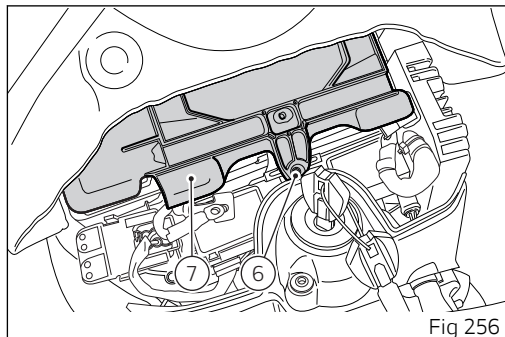
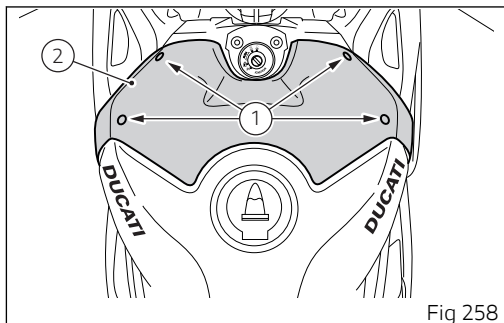
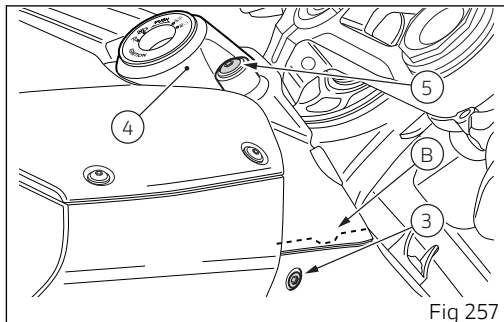

Fig 256

Position the ignition switch cover (4), operating from the front and paying attention to the inner tabs (B) connected to the side fairing, positioned on both sides.

Tighten the two side (3) and upper (5) screws retaining the ignition switch cover (4).  
Fit the tank cover (2) and tighten the four screws (1).



## Storing the motorcycle

If the motorcycle is not used for a long time (e.g. 30 consecutive days), it is advisable to connect the battery charger/charge maintainer using the connection cable through the diagnostic socket. Details are described in chapter "Charging and maintenance of the battery during winter storage".

## Charging and maintenance of the battery during winter storage

### Attention

The electric system of this motorcycle is designed so as to ensure there is a very low power drain when the motorcycle is OFF. Nevertheless, the battery features a certain self-discharge rate that is normal and depends on ambient conditions as well as on vehicle "non-use" time.

If battery is not kept at a minimum charge level by the battery charger / charge maintainer, battery could get damaged if voltage drops under 8 V.

Connector (1) is located under the rider seat (2), on the left side.

To reach it, remove the two screws (3) on both sides and remove the rider seat (2).

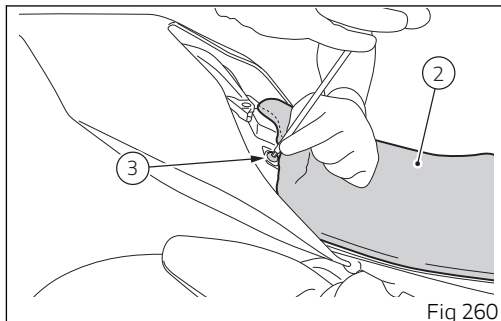
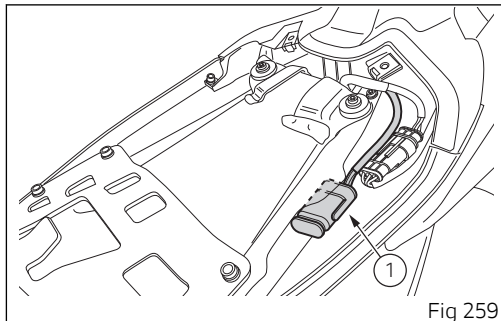

## Attention

Use only the Ducati-approved battery charger (A) for lithium batteries also as a maintainer. Do not use the battery charge maintainer kit part no. 69924601A (various countries) or battery charge maintainer kit no. 69924601AX (for Japan, China and Australia only), as it is specific for lead batteries.

Connect the maintainer to the diagnostics socket located in the rear side of the motorcycle.

## Note

Using charge maintainers or battery chargers for lithium batteries not approved by Ducati could damage motorcycle electric system and/or lithium battery; motorcycle warranty does not cover the battery if damaged due to failure to comply with the above indications, since it is considered as improper maintenance.

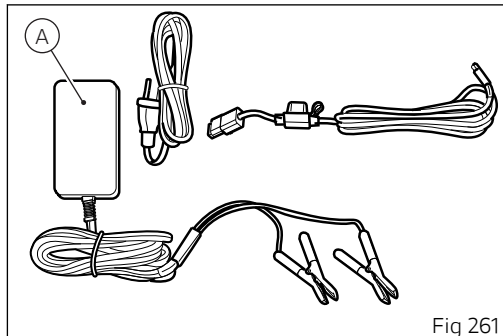

Fig 261

## Important

Vehicles equipped with lithium batteries must never use devices such as Jump Starters or auxiliary batteries connected in parallel to the lithium battery if the latter has discharged to a level that does not allow starting. The cells of a lithium battery, if deeply discharged, can be irreparably damaged if they are recharged with unlimited currents, as is the case with connections to Jump Starters and/or parallel connections to charged batteries.

Always use the battery charger (A) for lithium batteries authorised by Ducati.

## Checking drive chain tension



### Important

Have chain tension adjusted by a Ducati Dealer or authorised Service Centre.

Make the rear wheel turn until you find the position where chain is tightest. Set the motorcycle on the side stand. With just a finger, push down the chain at the point of measurement and release.

Measure the distance (A) between the centre of the chain pins and the plastic section of the chain sliding shoe. It must be:  $A = 23 \div 25$  mm (0.90  $\div$  0.98 in).



### Important

This only applies to the motorcycle STANDARD settings, available upon delivery.

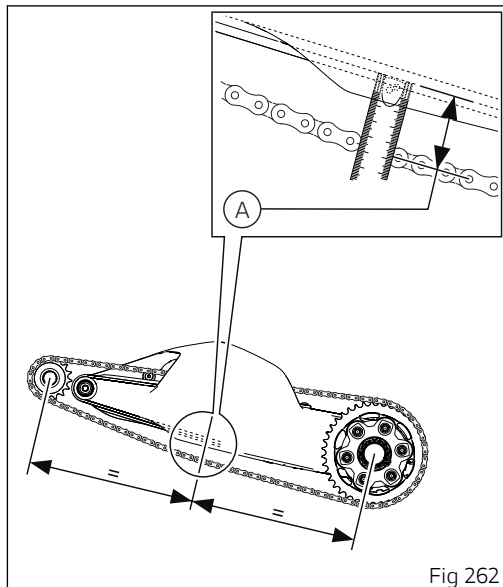



### Attention

Correct tightening of swinging arm screws (1) is critical to rider safety.



### Important

Improper chain tension will lead to early wear of transmission parts.



### Important

To ensure the best performance and long life of the chain, please follow the information related to chain cleaning, lubrication, inspection and tensioning.

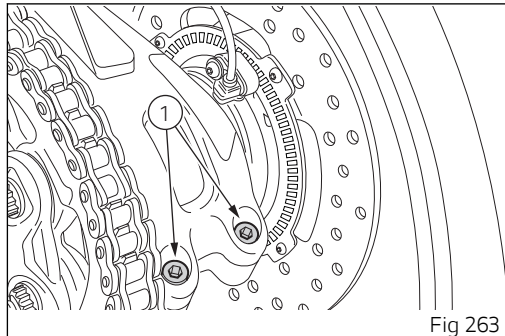

## Lubricating the drive chain



### **Important**

Have drive chain cleaned by a Ducati Dealer or authorised Service Centre.

### **Cleaning and lubricating the drive chain**

The chain fitted on your motorcycle has O-rings that keep dirt out of and lubricant inside the sliding parts. Before proceeding with the chain lubrication it is important to correctly wash and clean it.

The chain cleaning is extremely important for its duration. In fact, it is necessary to remove any mud, soil, sand or dirt from the chain using a jet of water and then dry it immediately using compressed air at a distance of at least 30 cm (11.81 in).



### Attention

Avoid the use of steam, fuel, solvents, hard brushes or other methods that could damage the O-rings; also avoid direct contact with the battery acid as it could cause mini cracks in the links as shown in the figure.



### Attention

In particular, in case of Off-Road use of the bike, it is possible that excessive wear of the links occurs due to the contact with the chain sliding shoe; friction could in fact cause the chain to overheat, altering the heat treatment of the links and making them particularly fragile.

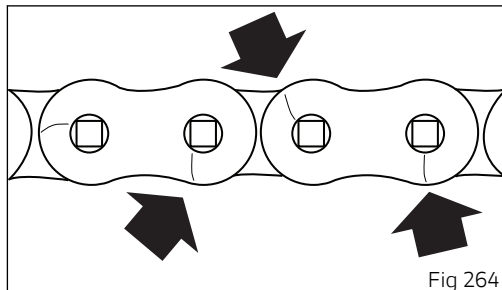

## Lubricating the drive chain



### Important

Have drive chain cleaned by a Ducati Dealer or authorised Service Centre.



### Attention

Use SHELL Advance Chain to lubricate the chain; the use of non-specific lubricants could damage the O-rings and therefore the entire drive system.

It is recommendable to lubricate the chain without waiting for it to cool down after using the motorcycle, so that the new lubricant can penetrate better between the inner and outer links and be more effective in its protective action.

Place the bike on the rear paddock stand. Make the rear wheel turns fast in the opposite direction to the direction of travel.

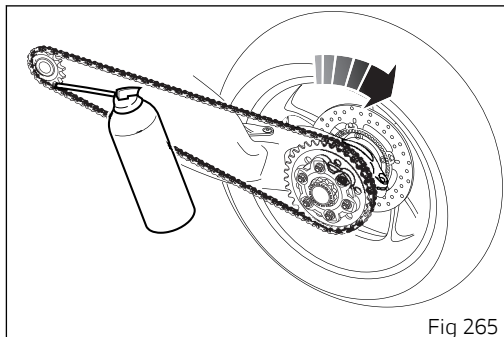

Apply the lubricant jet (1) inside the chain between the inner and outer links, in point (2) immediately before the engagement point on the sprocket.

Due to the centrifugal force, the lubricant, made fluid by the solvents contained in the spray, will expand in the working area between the pin and the bush, ensuring perfect lubrication.

Repeat the operation by aiming the lubricant jet to the central part (5) of the chain so as to lubricate the rollers (4), and to the outer plates (6) as shown in the figure.

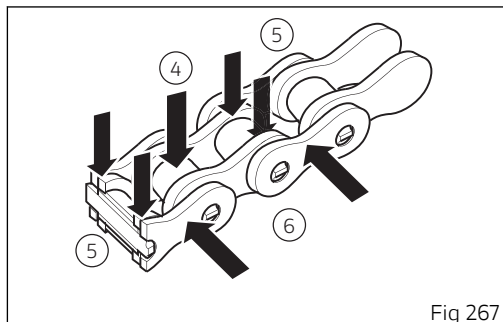
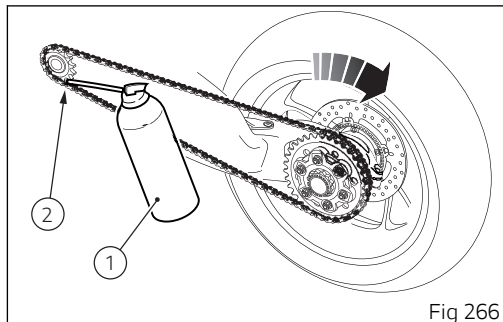

After lubrication, wait 10-15 minutes to allow the lubricant to act on the internal and external surfaces of the chain and then remove the excess lubricant with a clean cloth.

**⚠ Important**

Do not use the motorcycle immediately after lubricating the chain as the lubricant, still fluid, would be centrifuged outwards causing possible soiling of the rear tyre or the rider's footpeg.

**⚠ Important**

Check the chain often, taking care to lubricate it, as also indicated in the table below: at least every 1000 km (621 mi) or more frequently (about every 400 km (248 mi)) when using the bike with high outside temperatures (40°C) or after long travels on the highway at high speed.

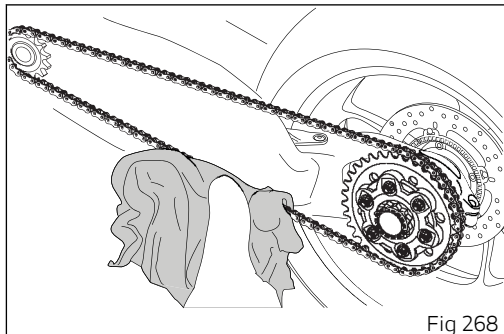

Fig 268

## Replacing the high and low beam bulbs

The whole front LED headlight assembly is maintenance-free. Figure shows the locations of the high beam (HI), low beam (LO) and parking lights (1). Have the lights replaced at a Ducati Dealer or authorised Service Centre.

## Rear turn indicators

LED turn indicator lights are maintenance-free.

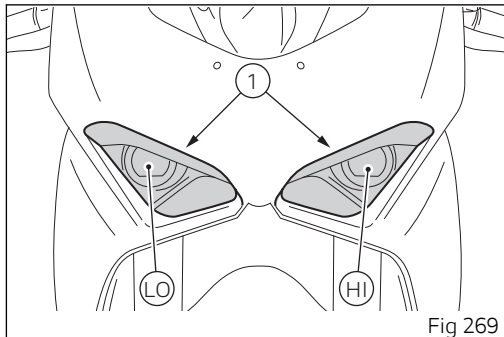

Fig 269

## Aligning the headlight

Check correct headlight aiming. Position the motorcycle 10 metres from a wall or a screen, the motorcycle must be perfectly upright with the tires inflated to the correct pressure and with a rider seated, perfectly perpendicular to the longitudinal axis. On the wall or surface, draw a horizontal line at the same height from the ground as the centre of the headlight and a vertical line aligned with the longitudinal axis of the motorcycle. If possible, perform this check in dim light. Switch on the low beam and adjust right and left beams. The height of the upper limit between the dark area and the lit area must not be more than  $\frac{9}{10}$  of the height from the ground of the headlight centre.

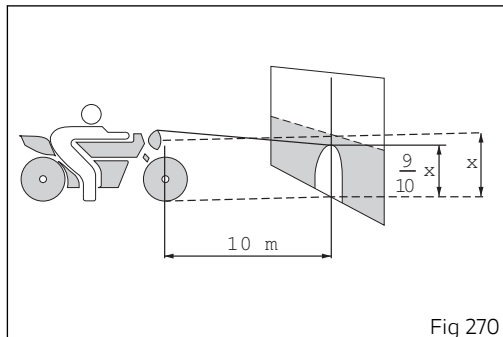

Fig 270

## Note

This is the procedure specified by Italian regulations for checking the maximum height of the light beam. Please adapt said procedure to the provisions in force in your own country.

To align the headlight beam, turn the screws (1) and (2) located at the front of the vehicle, on both sides.

Screw (1), positioned on the left side, acts on the high beam:

- turn clockwise to lower the light beam;
- turn counter clockwise to raise the light beam.

Screw (2), positioned on the right side, acts on the low beam:

- turn clockwise to lower the light beam;
- turn counter clockwise to raise the light beam.

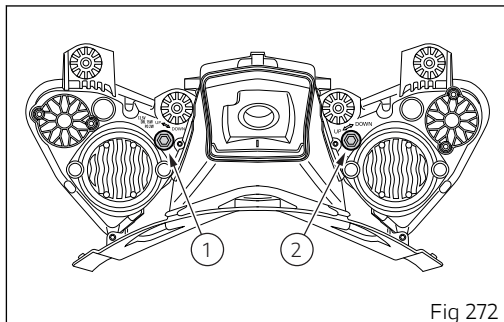
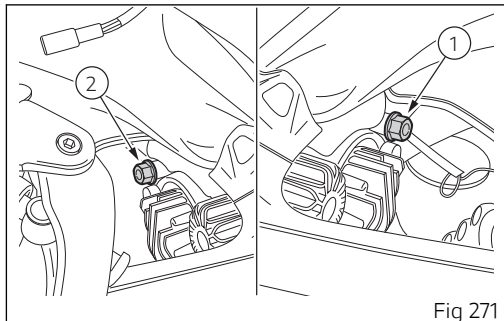



## Attention

The headlight might fog up if the motorcycle is used under the rain or after washing. Switch headlight on for a short time to dry up any condensate.

## Adjusting the rear-view mirrors

Manually adjust the rear-view mirror by pushing at point (A).

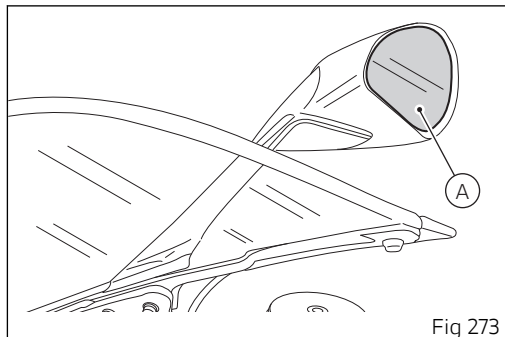

## Tubeless tyres

On the road (rider only)

2.3 bar (33.36 psi) (front) - 2.1 bar (30.46 psi) (rear).

On the road (rider + passenger):

2.5 bar (36.26 psi) (front) - 2.9 bar (42.06 psi) (rear).

On track (rider only):

2.3 bar (33.36 psi) (front) - 1.8 bar (26.10 psi) (rear).

As tyre pressure is affected by ambient temperature and altitude variations, you are advised to check and adjust it whenever you are riding in areas where ample variations in temperature or altitude occur.

### Attention

Check and set tyre pressure when tyres are cold. To avoid front wheel rim distortion, when riding on bumpy roads, increase tyre pressure by 0.2 ÷ 0.3 bar (2.90÷4.35 psi).

### Tyre repair or change (Tubeless tyres)

In the event of a tiny puncture, tubeless tyres will take a long time to deflate, as they tend to keep air inside. If you find low pressure on one tyre, check the tyre for punctures.

### Attention

In case of puncture replace the tyre. Replace the tyres using the make and type of the original equipment. Make sure that protective caps of valves are tightened to avoid pressure drops while riding. Never use tube type tyres; failure to comply with this provision can cause the sudden explosion of the tyre, with severe consequences for the rider.

After replacing a tyre, the wheel must be balanced.

### Attention

Do not remove or shift the wheel balancing weights.

### Note

Have the tyres replaced at a Ducati Dealer or authorised Service Centre. Correct removal and installation of the wheels is essential. Some parts of the ABS (such as sensors and phonic wheels) are mounted to the wheels and require specific adjustment.

## Minimum tread depth

Measure tread depth (S) at the point where tread is most worn down: it should not be less than 2 mm (0.08 in), and in any case not less than the legal limit.



### Important

Visually inspect the tyres at regular intervals for detecting cracks and cuts, especially on the side walls, bulges or large spots that are indicative of internal damage. Replace them if badly damaged. Remove any stones or other foreign bodies caught in the tread.

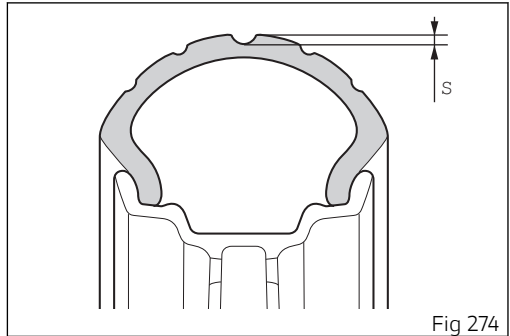

## Check engine oil level

Engine oil level can be checked through the sight glass (1) located on the left side of the engine block. Oil level should be between the marks on the sight glass. If the level is low, top up with engine oil.

Ducati recommends you use Shell Advance 4T Ultra 15W-50 oil (JASO: MA2 and API: SN).

Remove the oil filler cap (2) located on the right side of the vehicle and top up until the oil reaches the required level. Refit the filler plug (2).

### Important

Engine oil and oil filters must be changed by a Ducati Dealer or authorised Service Centre at the intervals specified in the scheduled maintenance chart reported in the Warranty Card.

To check the oil level correctly, carefully follow the instructions below.

- 1) The level check must be carried out with engine off for at least 2 hours, to allow time for the oil flowed in the cylinder heads to reach the sump.
- 2) Position the bike with both wheels on a flat ground and in straight position.
- 3) Then, check the engine oil through the sight glass.

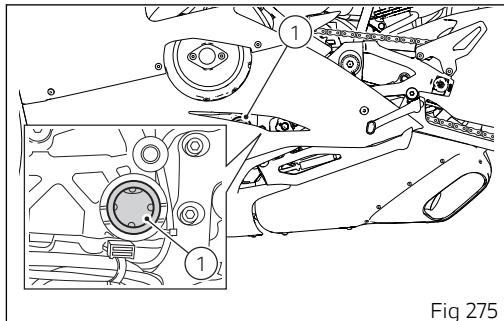

Fig 275

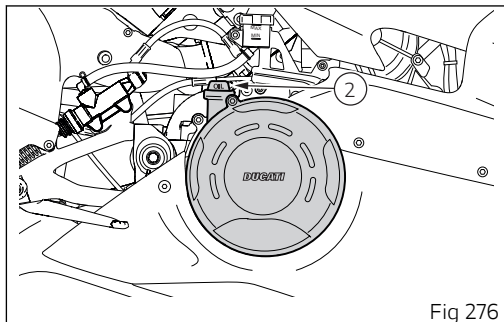

Fig 276

4) If the oil level is below the middle line between the MIN and MAX marks, add oil until reaching the maximum level indication.



### **Attention**

Never exceed the MAX mark.

### Recommendations concerning oil

It is recommended to use oil complying with the following specifications:

- viscosity grade SAE 15W-50;
- standard API: SN;
- standard JASO: MA2.

SAE 15W-50 is an alphanumeric code identifying oil class based on viscosity: two figures with a W ("winter") in-between; the first figure indicates oil viscosity at low temperature; the second figure indicates its viscosity at high temperature. API (American standard) and JASO (Japanese standard) standards specify oil characteristics.

## Cleaning the motorcycle

To preserve the finish of metal parts and paintwork, wash and clean your motorcycle at regular intervals, anyway according to road conditions. Use specific products only. Prefer biodegradable products. Avoid aggressive detergents or solvents.

Use only water and neutral soap to clean the Plexiglas and the seat.

Periodically clean by hand all aluminium components. Use special detergents, suitable for aluminium parts. Do NOT use abrasive detergents or caustic soda.



### Note

Do not use sponges with abrasive parts or steel wool: only use soft cloths.

However, the warranty does not apply to motorcycles whenever poor maintenance status is ascertained.



### Important

Do not wash your motorcycle right after use. When the motorcycle is still hot, water drops will evaporate faster and spot hot surfaces.

Never clean the motorcycle using hot or high-pressure water jets.

Cleaning the motorcycle with a high pressure water jet may lead to seizure or serious faults in forks, wheel hubs, electric system, headlight (fogging), fork seals, air inlets or exhaust silencers, with consequent loss of compliance with the safety requirements.

Clean off stubborn dirt or exceeding grease from engine parts using a degreasing agent. Be sure to avoid contact with drive parts (chain, sprockets, etc.).

Rinse with warm water and dry all surfaces with chamois leather.



### Attention

Braking performance may be impaired immediately after washing the motorcycle. Never grease or lubricate the brake discs to avoid losing braking power. Clean the discs with an oil-free solvent.



### Attention

The headlight might fog up due to washing, rain or moisture. Switch headlight on for a short time to help and dry up any condensate.

Carefully clean the phonic wheels of the ABS in order to ensure system efficiency. Do not use aggressive products in order to avoid damaging the phonic wheels and the sensors.



### Attention

Avoid direct contact between instrument panel lens and oils/fuels that may stain or damage it thereby impairing information readability. To clean such parts, do not use alcohol-based detergents, containing solvent or abrasive agents; do not use sponges or cloths featuring hard or rough areas since they might scratch the surface.



### Note

Clean instrument panel lens using soft cloths with water and mild soap or detergents specific for cleaning clear plastic parts.



### Note

To clean the instrument panel do not use alcohol or its by-products.

Pay special attention when cleaning the wheel rims since they have parts in machined aluminium; clean and dry them every time you use the vehicle.



### Important

To clean and lubricate the drive chain, refer to the paragraph "Lubricating the drive chain".

## Cleaning and replacing the spark plugs

Spark plugs are essential to smooth engine running and should be checked at regular intervals. Have the spark plug replaced by a Ducati Dealer or an authorised Service Centre.

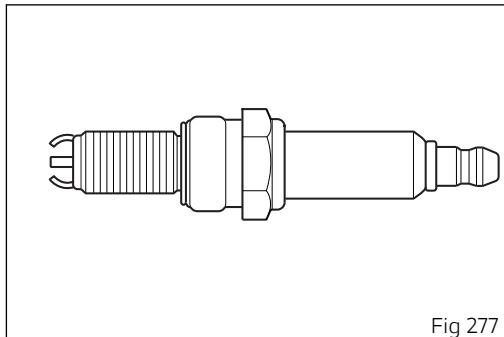

Fig 277

## Storing the motorcycle

If the motorcycle is to be left unriden over long periods, it is advisable to carry out the following operations before storing it away:

- clean the motorcycle;
- empty the fuel tank;
- place the motorcycle on a service stand;
- disconnect, remove the battery and periodically charge it using the battery maintainer;
- protect the motorcycle with a suitable canvas. This will protect paintwork and let condensate breathe out. The canvas is available from Ducati Performance.

## **Important notes**

Some countries, such as France, Germany, Great Britain, Europe, Switzerland, etc. have compulsory emission and noise standards that include mandatory inspections at regular intervals.

Periodically carry out the required checks and renew parts as necessary, using Ducati original spare parts, in compliance with the regulations in the country concerned.

# Scheduled maintenance chart

Scheduled maintenance chart: operations to be carried out by the dealer



## Attention

This scheduled maintenance chart is designed for a road use of the Panigale V4. If it is used on the track, even if not during sport competitions, all parts of the motorcycle are more stressed so the routine maintenance operations must be carried out more frequently than indicated.



## Attention

Please contact a Ducati Dealer or authorised Service Centre where you can receive customised service advice according to the sport use you make of your Panigale V4.

List of operations and type of intervention [set mileage (km/mi) or time interval *]	Km. x1000	1	12	24	36	48	Time (months)
	mi. x1,000	0.6	7.5	15	22.5	30	
Reading of the error memory with DDS 2.0 and check of Software version update on control units		•	•	•	•	•	12
Check the presence of any technical updates and recall campaigns		•	•	•	•	•	12
Change engine oil and filter		•	•	•	•	•	12

List of operations and type of intervention [set mileage (km/mi) or time interval *]	Km. x1000	1	12	24	36	48	Time (months)
	mi. x1,000	0.6	7.5	15	22.5	30	
Change engine oil mesh filter assembly				●		●	-
Check and/or adjust valve clearance				●		●	-
Visual check for wear of the chain timing system and of the oil pump drive chain						●	-
Change spark plugs				●		●	-
Clean air filter			●		●		-
Change air filter				●		●	-
Replace the fastening screws of clutch cover, clutch protection cover, generator cover, and oil sump				●		●	-
Check brake and clutch fluid level		●	●	●	●	●	12
Change brake and clutch fluid							24
Check brake pads. Change, if necessary		●	●	●	●	●	12
Check the proper tightening of brake calliper bolts and brake disc flange screws		●	●	●	●	●	12
Check front and rear wheel nuts tightening		●	●	●	●	●	12
Check wheel hub bearings				●		●	-

List of operations and type of intervention [set mileage (km/mi) or time interval *]	Km. x1000	1	12	24	36	48	Time (months)
	mi. x1,000	0.6	7.5	15	22.5	30	
Check and lubricate the rear wheel shaft				●		●	24
Check the cush drive damper on rear sprocket				●		●	-
Check the proper tightening of final drive front and rear sprocket nuts		●	●	●	●	●	12
Check final drive chain sliders for wear		●	●	●	●	●	12
Check final drive chain tension and lubrication		●	●	●	●	●	12
Check steering bearings and lubricate, if necessary				●		●	24
Change front fork fluid							36
Visually check the front fork and rear shock absorber seals		●	●	●	●	●	12
Check for proper tightening of the frame-to-engine fasteners and swinging arm			●	●	●	●	-
Check the freedom of movement and tightening of the side stand		●	●	●	●	●	12
Visually check the fuel lines			●	●	●	●	12
Check rubbing points, clearance, freedom of movement and positioning of hoses and electric wiring in view		●	●	●	●	●	12

List of operations and type of intervention [set mileage (km/mi) or time interval *]	Km. x1000	1	12	24	36	48	Time (months)
	mi. x1,000	0.6	7.5	15	22.5	30	
Lubricate the levers at the handlebar and pedal controls			•	•	•	•	12
Change coolant						•	48
Check coolant level		•	•	•	•	•	12
Check electric fan operation		•	•	•	•	•	12
Check tyre pressure and wear		•	•	•	•	•	12
Check the battery charge level		•	•	•	•	•	12
Check idling		•	•	•	•	•	12
Adjustment of the Bowden cable of the exhaust valve opening through the DDS 2.0		•		•		•	-
Check secondary air system operation				•		•	-
Check the operation of all electric safety devices (side stand sensor, front and rear brake switches, engine kill switch, gear/neutral sensor)		•	•	•	•	•	12
Reset the variable-length intake manifold system (VIS) using DDS 2.0				•		•	-
Check the indicators and lighting		•	•	•	•	•	12
Reset the Service indication through the DDS 2.0		•	•	•	•	•	-

List of operations and type of intervention [set mileage (km/mi) or time interval *]	Km. x1000	1	12	24	36	48	Time (months)
	mi. x1,000	0.6	7.5	15	22.5	30	
Road test of the motorcycle, testing the safety devices (ex. ABS and DTC)		•	•	•	•	•	12
Softly clean the motorcycle		•	•	•	•	•	12
Fill out that the service was performed in on-board documentation (Service Booklet)		•	•	•	•	•	12

\* Service operation to be carried out in accordance with the specified distance or time intervals (km, miles or months), whichever occurs first.

## Scheduled maintenance chart: operations to be carried out by the customer



### Important

Using the motorcycle under extreme conditions, such as very damp and muddy roads or dusty and dry environment, could cause above-average wear of components like the drive system, the brakes or the air filter. If the air filter is dirty, the engine could get damaged. Therefore, this might translate in required service or replacement of the wear parts earlier than specified in the scheduled maintenance chart.

List of operations and type of intervention [set mileage (km/mi) or time interval *]	Km. x1000	1
	mi. x1,000	0.6
	Months	6
Check engine oil level		•
Check brake and clutch fluid level		•
Check tyre pressure and wear		•
Check the drive chain tension and lubrication. If necessary, contact your dealer to adjust components.		•
Check chain and sprocket for wear. If necessary, contact your dealer to replace components.		•
Check brake pads. If necessary, contact your dealer to replace components.		•

\* Service operation to be carried out in accordance with the specified distance or time intervals (km, miles or months), whichever occurs first.

# Technical data

## Weights

Overall weight (in running order with 90% of fuel - 44/2014/EU Annex XI): 195 kg (429.90 lb).

Overall weight (without fluids and battery): 174 kg (383.60 lb).

Maximum allowed weight (carrying full load): 370 kg (815.71 lb).



### Attention

Failure to observe weight limits could result in poor handling and impair the performance of your motorcycle, and you may lose control of the motorcycle.

## Dimensions

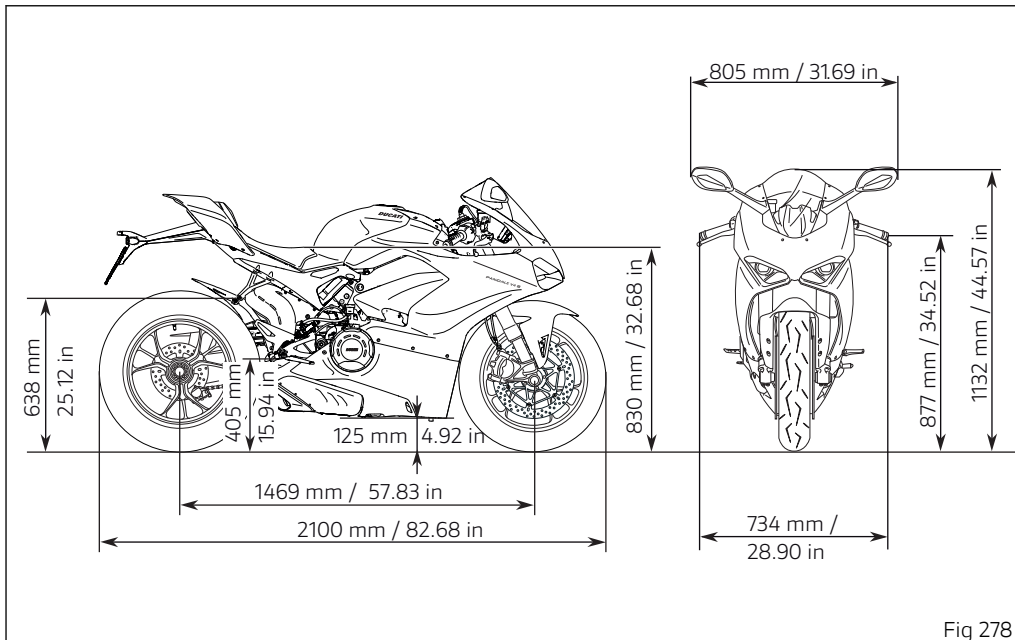

Fig 278

## Fuel, lubricants and other fluids

TOP-UPS	TYPE	
Fuel tank, including a reserve of 4.5 litres (0.99 UK gal)	Ducati recommends SHELL V-Power unleaded premium fuel with a minimum of octane rating of RON 95	16 litres (3.52 UK gal)
Oil sump and filter	Ducati recommends use of SHELL Advance 4T Ultra 15W-50 (JASO: MA2, API: SN)	3.4 litres (0.75 UK gal)
Front/rear brake and clutch circuits	DOT 4	-
Protectant for electric contacts	Protective spray for electric systems	-
Front fork	SHELL Donax TA	230 mm (9.05 in) 382 ± 4 cu. cm (23.31 ± 0.24 cu in)
Cooling circuit	ENI Agip Permanent Spezial antifreeze (do not dilute, use pure)	2.05 litres (0.45 UK gal)



### Important

Do not use any additives in fuel or lubricants. Using them could result in severe damage of the engine and motorcycle components.



### Attention

The motorcycle is only compatible with fuel having a maximum content of ethanol of 10% (E10). Using fuel with ethanol content over 10% is forbidden. Using it could result in severe damage of the engine and motorcycle components. Using fuel with ethanol content over 10% will make the warranty null and void.



### Important

These references indicate the fuel recommended for this vehicle as specified by the European regulation EN228.



## Engine

Desmosedici Stradale: V4 90°, counter-rotating crankshaft, Desmodromic timing system, 4 valves per cylinder, liquid cooling.

Bore: 81 mm (3.19 in)

Stroke: 53.3 mm (2.1 in)

Total displacement: 1,103 cu. cm (67.31 cu. in)

Compression ratio: 14.0 ± 0.5:1

Maximum power at crankshaft (EU) Regulation no. 134/2014, Annex X, kW/HP:

157.5 kW/214.0 HP at 13,000 rpm

Max. power at crankshaft Regulation (EU) no. 134/2014 Annex X kW, for France version only:

84 kW/114.2 HP at 10,500 rpm

Maximum torque at crankshaft (EU) Regulation no. 134/2014 Annex X:

124 Nm - 12.6 kgm at 10,000 rpm

Max. torque at crankshaft Regulation (EU) no. 134/2014 Annex X, for France version only:

99 Nm - 10.1 Kgm at 7,500 rpm

Maximum rpm: 14,500 rpm / 15,000 rpm (6th gear).



### Note

The engine control unit disables the 2 rear bank cylinders when engine is idling and the throttle twistgrip is fully released. This disabling is only implemented when some conditions are verified and namely depending on the engine temperature, gear engaged and clutch lever position (that must be completely pulled unless gear is in Neutral). This strategy ensures advantages in terms of fuel economy and rider's comfort because of less heat.



### Important

Do not exceed the specified rpm limits in any running conditions.



### Note

The indicated power/torque values have been measured with a static test bench according to type-approval standards and match with the data detected during type-approval process; they are indicated in the vehicle registration document.

## Timing system

Desmodromic, 4 valves per cylinder

Desmodromic timing system

- 1) Opening (or upper) rocker arm;
- 2) Opening rocker shim;
- 3) Closing (or lower) rocker shim;
- 4) Return spring for lower rocker;
- 5) Closing (or lower) rocker;
- 6) Camshaft;
- 7) Valve.

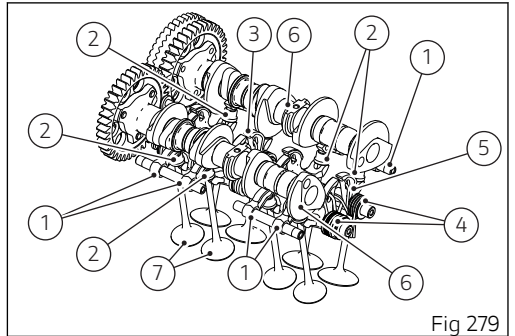

## Performance data

Maximum speed in any gear should be reached only after a correct running-in period with the motorcycle properly serviced at the recommended intervals.



## Important

Failure to follow these instructions releases Ducati Motor Holding S.p.A. from any liability whatsoever for any engine damage or shorter engine life.

## Spark plugs

Make: NGK.

Type: LMDR10A-JS.

## Fuel system

Inductive discharge indirect electronic injection,

intake system with variable length ducts

Throttle body: Full Ride-by-Wire elliptical (corresponding diameter):

52 mm (2.05 in)

Injectors per cylinder: 2

Fuel supply: 95-98 RON.



## Attention

The motorcycle is only compatible with fuel having a maximum content of ethanol of 10% (E10). Using fuel with ethanol content over 10% is forbidden. Using it could result in severe damage of the engine and motorcycle components. Using fuel with ethanol content over 10% will make the warranty null and void.

## Brakes

Separate-action anti-lock braking system operated by hall-type sensors mounted to each wheel with phonic wheel detection: ABS can be disabled.

### FRONT

Semi-floating drilled twin-disc.

Braking material: stainless steel.

Carrier material: aluminium.

Disc diameter: 330 mm (12.99 in).

Brake disc thickness: 5 mm (0.2 in)

Hydraulically operated by a control lever on handlebar right-hand side.

Brake calliper make: BREMBO.

Type: Stylema monobloc (R) M4.30, radial mount (ABS Cornering EVO)

Number of pistons per calliper: 4

Friction material: BRM10H.  
Master cylinder type: PR16/21.

## REAR

With fixed drilled stainless steel disc.  
Disc diameter: 245 mm (9.6 in).  
Brake disc thickness: 5 mm (0.2 in)  
Hydraulically operated by a pedal on RH side.  
Brake calliper make: BREMBO  
Number of pistons per calliper: 2.  
Cornering ABS as standard.  
Friction material: Ferodo Ferit I/D 450 FF.  
Master cylinder type: PS 13.  
Master cylinder diameter: 13 mm (0.51 in).

### Attention

The brake fluid used in the brake system is corrosive.  
In the event of accidental contact with eyes or skin, wash the affected area with abundant running water.

## Transmission

Hydraulically-controlled slipper/self-servo wet multiplate clutch controlled by the lever on left-hand side of the handlebar.

Drive is transmitted from engine to gearbox primary shaft via spur gears.

Primary drive: 1.80:1

6-gear gearbox with Ducati Quick Shift (DQS) up/down EVO, gear change pedal on left side of motorcycle.

Gearbox output sprocket/rear chain sprocket ratio: 16/41

Total gear ratios:

1<sup>st</sup> gear 38/14

2<sup>nd</sup> gear 36/17

3<sup>rd</sup> gear 33/19

4<sup>th</sup> gear 32/21

5<sup>th</sup> gear 30/22

6<sup>th</sup> gear 30/24

Drive chain from gearbox to rear wheel.

Make: DID 525HV3 KAI ZB

Links: 114

### Important

The above gear ratios are the homologated ones and under no circumstances must they be modified.

However, if you wish to tune up your motorcycle for competitions or special tracks, Ducati Motor Holding S.p.A. will be pleased to provide information about the special ratios available. Contact a Ducati Dealer or Authorised Service Centre.



### Attention

If the rear sprocket needs replacing, contact a Ducati Dealer or authorised Service Centre. Incorrect replacement of this component could seriously compromise your safety and cause irreparable damage to the motorcycle.

### Frame

Aluminium alloy frame.  
Aluminium alloy rear subframe.  
Steering head angle: 24.5°  
Steering angle: 26° LH side / 26° RH side  
Trail: 100 mm (3.93 in).

### Wheels

Front

3-spoke, aluminium alloy forged rim.  
Size: MT3.50x17"

Rear

3-spoke, aluminium alloy forged rim.  
Size: MT6.00x17"

### Tyres

Front

Pirelli Diablo Supercorsa SP "tubeless" radial type.  
Size: 120/70-ZR17.

Rear

Pirelli Diablo Supercorsa SP "tubeless" radial type.  
Size: 200/60-ZR17.

### Suspension

Front

Öhlins NIX30 upside-down fork with TiN coating of fork legs, completely adjustable.  
Electronic compression and rebound damping adjustment with Öhlins Smart EC 2.0 controlled semi-active mode  
Stanchion diameter:  
43 mm (1.7 in), TiN-coated.  
Wheel travel:  
120 mm (4.7 in).

Rear

Öhlins TTX36 fully adjustable monoshock.  
Electronic compression and rebound damping  
adjustment with Öhlins Smart EC 2.0 controlled  
semi-active mode.

Aluminium single-sided swinging arm.

Wheel travel:

130 mm (5.1 in).

Steering damper

Adjustable Öhlins steering damper

### **Exhaust system**

Layout 4 - 2 - 1 - 2: the exhaust system structure is 4  
into 2 into 1 into 2.

Two Lambda sensors and two catalytic converters.

### **Available colours**

Ducati Anniversary red 473.101 (PPG);

Primer (White Acriflex) code LMC06017 (LECHLER);

grey frame and black rims.

## Electric system

Basic electric items are:

Headlight type:

no.1 Luxeon Altilon LED + No.2 Luxeon F Plus LEDs  
(low beam);

No.1 Luxeon Altilon LED (high beam);

No.4 Luxeon F ES LEDs (parking light/DRL).

Electrical controls on handlebars.

LED front turn indicator type:

No.15 OSRAM LYE6SF LEDs

LED rear turn indicator type (Europe version):

No.1 PHILIPS LXM2-PL01 LED

BULB rear turn indicator type (USA version):

RY10W (12V-10W) Amber.

Tail light type:

No.18 OSRAM LSA67F LEDs.

LED stop lights type:

No.18 OSRAM LAE6SF LEDs

LED number plate light type:

No. 3 CREE CLA1A-WKW LEDs.

Horn.

Stop light switches.

Lithium-ion battery:

12.8V - 4Ah (LiFePO4 Battery).

Generator (Denso):

14V - 425W.

ELECTRONIC RECTIFIER, protected by a 30A fuse  
located on the solenoid starter, next to the battery.

Starter motor:

BA06 12V - 0.6 kW



### Note

For bulb replacement instructions, please see  
the paragraph "Replacing the high and low beam  
bulbs".

## Fuses

There are twelve fuses that protect the electric components, located inside the front fuse boxes, and one on the electric solenoid starter. There is a spare fuse in every box.

Refer to the table below to identify the circuits protected by the various fuses and their ratings. The front left fuse box (A, Fig 280) and the front right one (B, Fig 281) are located above the battery. To reach the fuses, remove the tank cover as described in chapter "Charging the battery". To expose the fuses, lift the box protective cover. Mounting position and ampere capacity are marked on box cover.

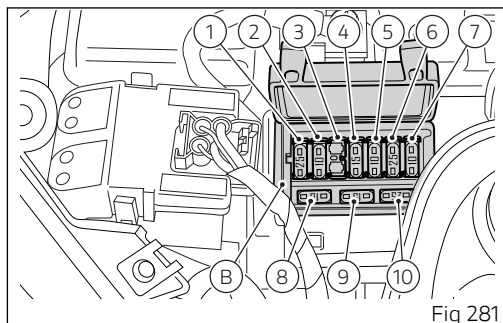
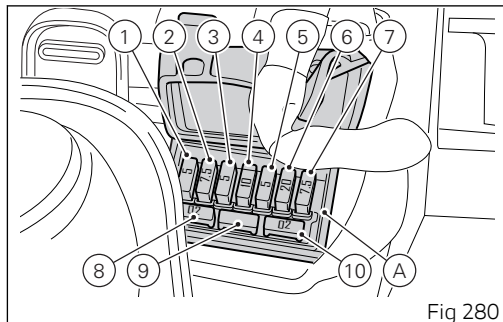

<b>Front left fuse box (A) key</b>		
Pos	El. item	Rat.
1	EMS/ABS/IMU	5 A
2	DASH/BBS/SMEC	7.5 A
3	Front optical unit	5 A
4	SBS	-
5	Accessories (SW)	5 A
6	Injection relay	20 A
7	Diagnostics/ Recharge	7.5 A
8	Spare	20 A
9	Spare	15 A
10	Spare	5 A

<b>Front right fuse box (B) key</b>		
Pos	El. item	Rat.
1	EMS powered relays	25 A
2	Fuel pump relay	10 A
3	Starter relay	-

<b>Front right fuse box (B) key</b>		
4	Instrument panel	15 A
5	Black Box System (BBS)	15 A
6	ABS 1	25 A
7	ABS 2	10 A
8	Spare	25 A
9	Spare	15 A
10	Spare	10 A

The main fuse (C) is located on the right side of the fuse box (B Fig 281), on solenoid starter (D). To reach it, it is necessary to remove the tank cover as described in chapter "Charging the battery" and the protection cap (E). A blown fuse can be identified by breakage of the inner filament (F).

**⚠ Important**  
Switch the ignition key to OFF before replacing the fuse to avoid possible short-circuits.

**⚠ Attention**  
Never use a fuse with a rating other than specified. Failure to observe this rule may damage the electric system or even cause fire.

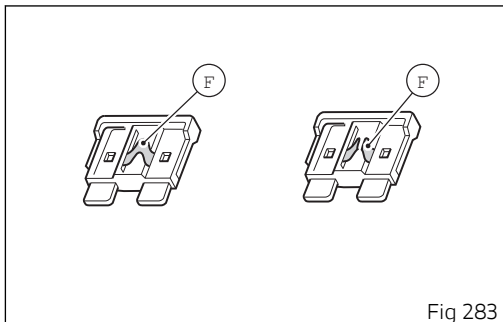
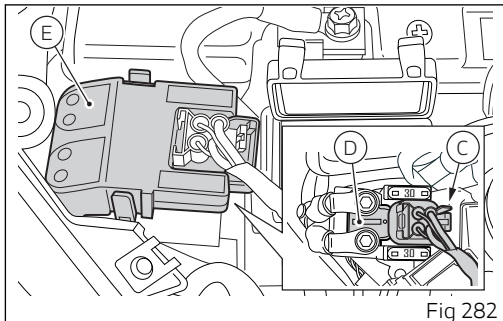

## Injection/electric system diagram key

- |     |  |     |                           |
|-----|--|-----|---------------------------|
| 1)  | Left-hand switch                         | 25) | Cylinder 1 upper injector |
| 2)  | Right-hand switch                        | 26) | Cylinder 4 rear injector  |
| 3)  | Front stop switch                        | 27) | Cylinder 3 rear injector  |
| 4)  | Immobilizer                              | 28) | Cylinder 2 front injector |
| 5)  | Ignition system (ignition switch)        | 29) | Cylinder 1 front injector |
| 6)  | LH fan                                   | 30) | Rear coil 4               |
| 7)  | RH fan                                   | 31) | Rear coil 3               |
| 8)  | Front speed sensor                       | 32) | Front coil 2              |
| 9)  | ABS control unit                         | 33) | Front coil 1              |
| 10) | Rear speed sensor                        | 34) | Purge valve               |
| 11) | Smart EC control unit                    | 35) | Secondary air actuator    |
| 12) | Vehicle control unit (BBS)               | 36) | Intake funnel motor (VIM) |
| 13) | Tail light                               | 37) | Rear potentiometer        |
| 14) | Diagnostics                              | 38) | Front potentiometer       |
| 15) | Main wiring / rear wiring cable coupling | 39) | Rear lambda sensor        |
| 16) | Main wiring / rear wiring cable          | 40) | Front lambda sensor       |
| 17) | Rear wiring                              | 41) | Rear knock sensor         |
| 18) | Rear right turn indicator                | 42) | Front knock sensor        |
| 19) | Number plate light                       | 43) | Side stand switch         |
| 20) | Rear left turn indicator                 | 44) | Quick shifter             |
| 21) | Engine control unit                      | 45) | Gear sensor               |
| 22) | Cylinder 4 upper injector                | 46) | Engine temperature        |
| 23) | Cylinder 3 upper injector                | 47) | Timing/rpm sensor         |
| 24) | Cylinder 2 upper injector                | 48) | Rear stop switch          |
|     |  | 49) | Rear MAP sensor 4         |
|     |  | 50) | Rear MAP sensor 3         |

- 51) Front MAP sensor 2
- 52) Front MAP sensor 1
- 53) Rear TPS
- 54) Front TPS
- 55) Accessory devices
- 56) Air temperature
- 57) Clutch switch
- 58) Front left turn indicator
- 59) GPS (optional)
- 60) Headlight
- 61) Instrument panel
- 62) Front right turn indicator
- 63) Oil pressure sensor
- 64) Horn
- 65) Fan relay
- 66) Steering damper
- 67) Front suspension compression
- 68) Front suspension rebound
- 69) Ex-up drive
- 70) Rear suspension compression
- 71) Rear suspension rebound
- 72) Fuel pump
- 73) Control unit relay (LOADS EMS)
- 74) Key-Sense relay
- 75) Fuel pump relay
- 76) LH fuse box

- 77) RH fuse box
- 78) Engine ground
- 79) Fused solenoid
- 80) Starter motor
- 81) Rectifier
- 82) IMU 1
- 83) IMU 2
- 84) APS sensor
- 85) Release connector 1
- 86) Release connector 2
- 87) Battery

#### Wire colour coding

- B Blue
- W White
- V Violet
- Bk Black
- Y Yellow
- R Red
- Lb Light blue
- Gr Grey
- G Green
- Bn Brown
- O Orange
- P Pink

**Note**

The electric system wiring diagram is at the end of this manual.

# Routine maintenance record

## Routine maintenance record

KM	NAME	MILEAGE	DATE
	DUCATI SERVICE		
1000			
12000			
24000			
36000			
48000			
60000			





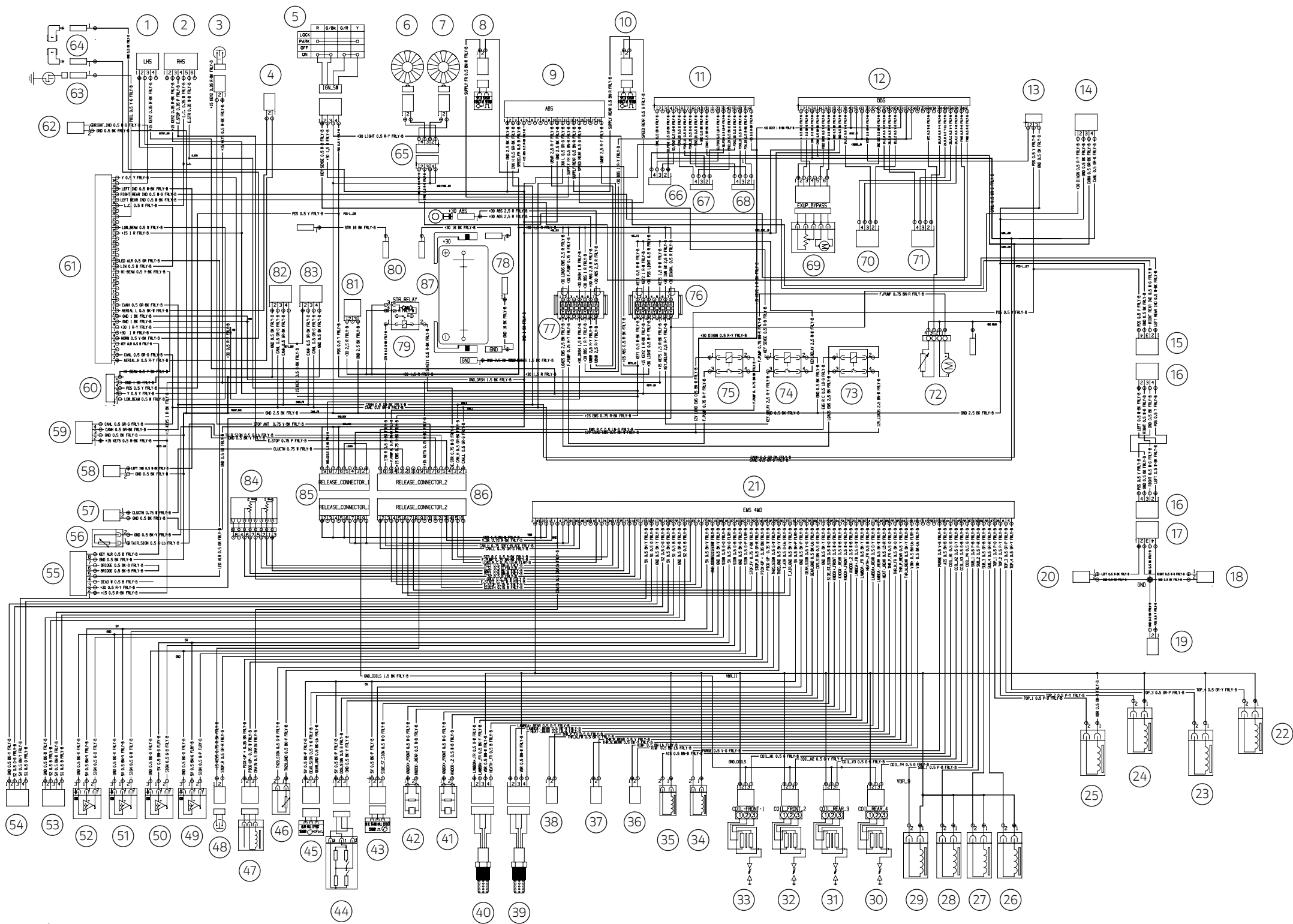

Panigale V4 S

**Ducati Motor Holding spa**  
ducati.com

Via Cavalieri Ducati, 3  
40132 Bologna, Italy  
Ph. +39 051 6413111  
Fax +39 051 406580

A Sole Shareholder Company  
A Company subject to the Management  
and Coordination activities of AUDI AG